



# Mixed-Signal MCU for Automotive and Industrial Motor Control Applications

## S12ZVMB

Last Updated: Jun 7, 2023

The S12ZVMB MCU family provides automotive DC-motor control applications with a combination of integration and scalability. Integrated LIN-PHY, 12V-Vreg, and H-Bridge Gatedriver allow building extremely compact solutions in window lifters, sunroofs or powertrain actuators.

## S12ZVMB Block Diagram Block Diagram

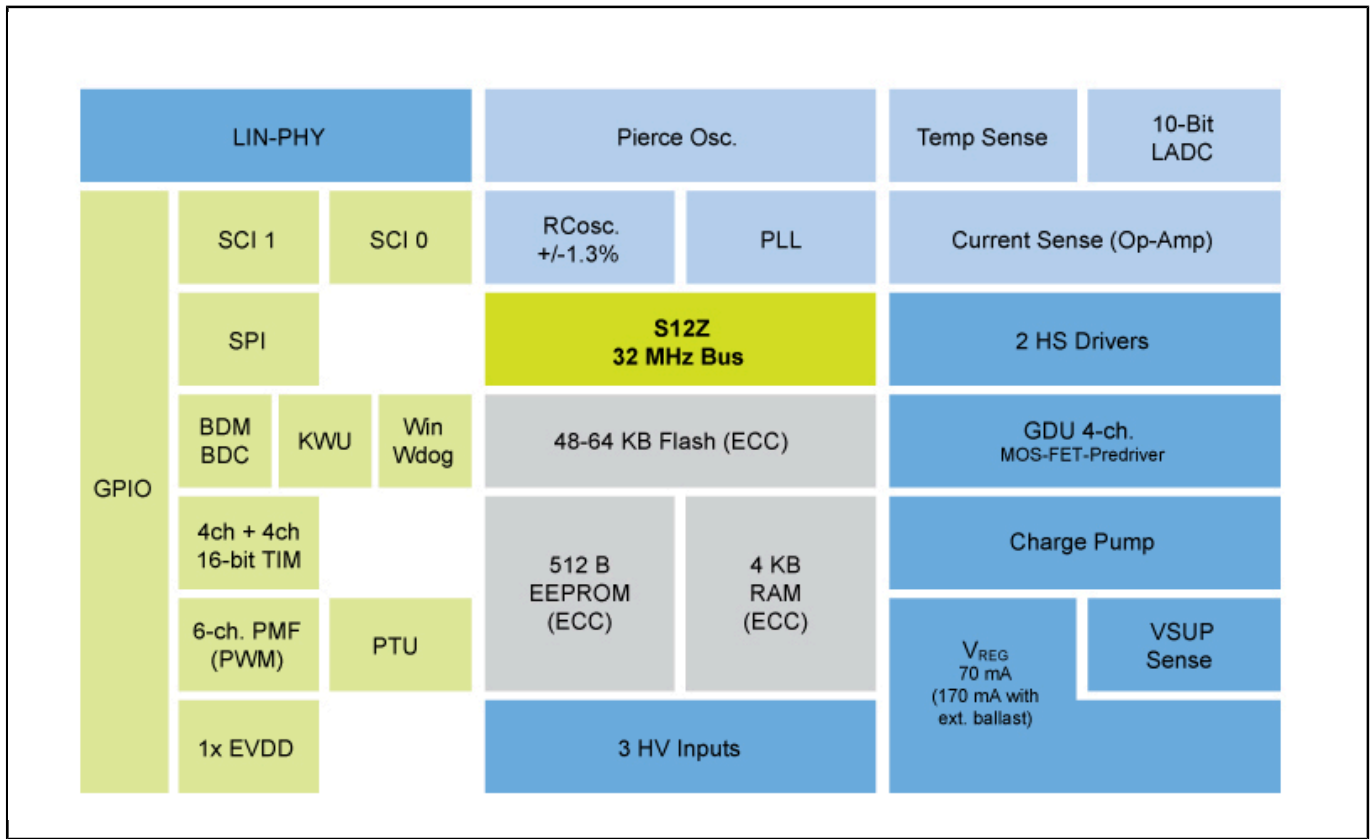

## S12ZVMB Device Image Block Diagram

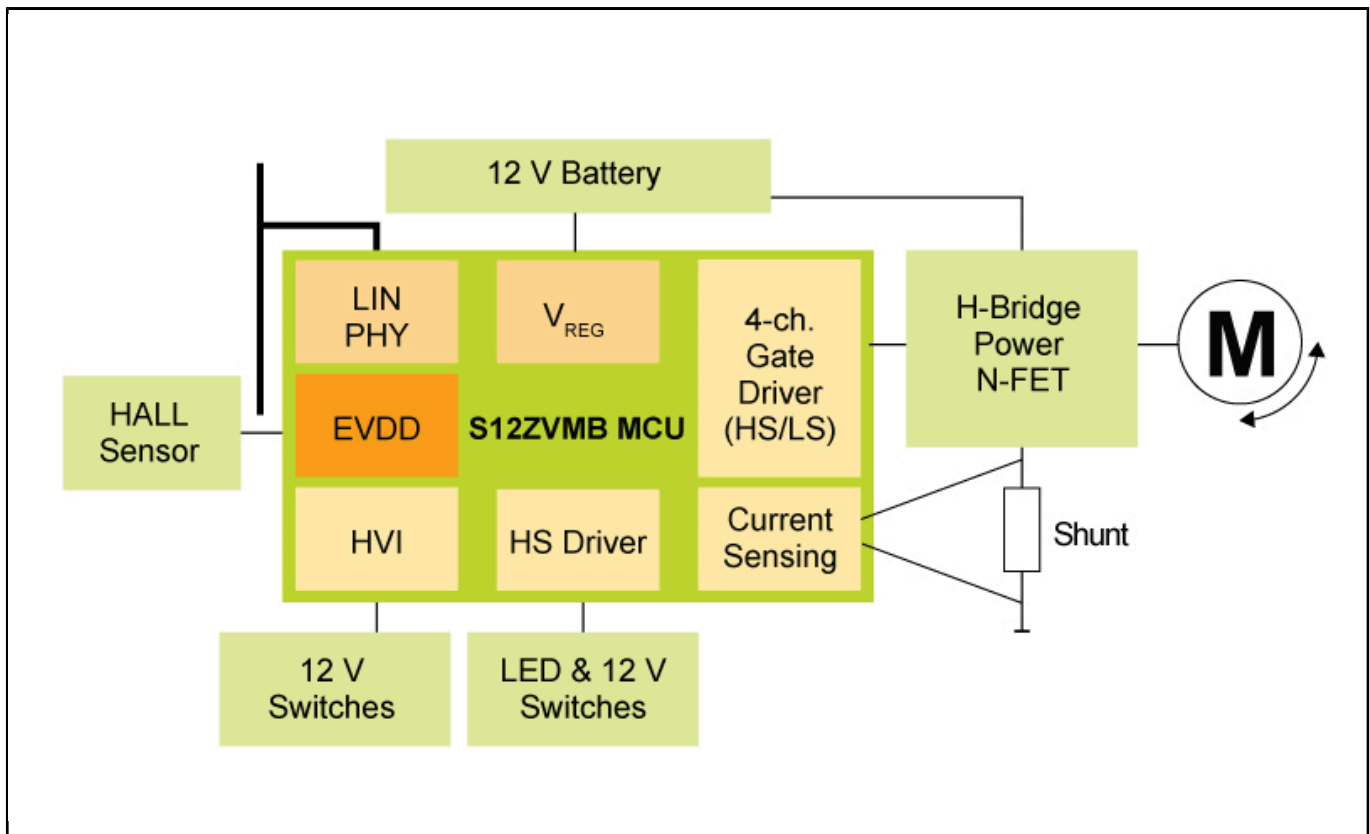

View additional information for [Mixed-Signal MCU for Automotive and Industrial Motor Control Applications](#).

**Note:** The information on this document is subject to change without notice.

---

**[www.nxp.com](http://www.nxp.com)**

NXP and the NXP logo are trademarks of NXP B.V. All other product or service names are the property of their respective owners. The related technology may be protected by any or all of patents, copyrights, designs and trade secrets. All rights reserved. © 2024 NXP B.V.