

**IEEE® 802.15.4 Technology from Freescale**  
Start with a leader. Finish strong.

### Freescale—the One-Stop Shop

Freescale provides all the building blocks used in a complete ZigBee® compliant platform solution: the RF transceiver, MAC and ZigBee software, microcontrollers and sensors.

The development hardware and reference designs provide developers with the tools they need to easily and quickly implement these building blocks. One solution, one provider—built, tested, compatible and ready for integration.

### Making Wireless Simple

Freescale draws on extensive radio frequency (RF) and wireless experience from more than 50 years of radio products development. With our depth of experience in this area, we are qualified to offer a comprehensive IEEE® 802.15.4 standard-compliant platform. Freescale's platform approach makes wireless simple by providing a one-stop shop for customers, complete with hardware, software, development tools and reference designs, all designed to help ease 802.15.4 wireless development and speed time to market.

### 802.15.4—Building the Foundation

IEEE 802.15.4 broke the “bigger and faster” mold when it was introduced in 2003. 802.15.4 was designed to address the need for a cost-effective and low-power wireless standard optimized for monitoring and control. Although it may be similar to other standards, features such as fast power-on latency and mesh networking help differentiate it from the field of existing IEEE technologies.

- 2.4 GHz: 16 channels, 250 kbps
- DSSS energy spreading scheme
- AES 128 encryption and authentication
- Simple frame structure
- Reliable data delivery
- CSMA-CA
- Message acknowledgement
- Energy detection and link quality indication

IEEE 802.15.4 has become a solid foundation for low rate wireless solutions, including ZigBee technology, the WirelessHART™ specification, SP100.11a network stack and other proprietary network stacks.

### Connections Everywhere

The benefits of simple, cost-effective, low-power wireless connectivity that 802.15.4 technology provides address a variety of markets, including:

- Consumer applications control
- Energy management
- Residential and commercial building automation
- Industrial process control
- Health care monitoring

The Freescale 802.15.4 platform supports a number of network offerings, including Freescale's simple MAC (SMAC), Synkro 802.15.4 MAC, Synkro entertainment control platform, BeeStack™ ZigBee protocol stack as well as other standard and third-party networks. These give developers the flexibility to build products optimized for different features, such as cost, performance, complexity and interoperability. The network stacks provide a key part of Freescale's platform solution, all designed to simplify development and speed time to market.

### Simple Wireless

SMAC is a simple and cost-effective start to wireless networking. Based on the 802.15.4 PHY, it provides commands to create simple point-to-point and star networks. The small code size, 2.5–4 K, allows a cost-effective MCU to be used in conjunction with the MC13201 RF transceiver, creating the ideal platform for many applications that need simple but effective wireless communication.

### Bringing Remote Control into the 21st Century

Freescale's Synkro protocol is a lightweight networking stack built on top of the IEEE 802.15.4 standard. The protocol was created to control, monitor and automate consumer electronic products including televisions, DVD players and recorders, set top boxes,

audio/video receivers, remote control and many more. Synkro overcomes the growing technology challenges that today's consumer electronic products face with 30 year old infrared (IR) technology by removing the line of site and field of vision issues while providing a fast bi-direction link to enhance user experiences. Freescale's Synkro starts with 802.15.4, but incorporates improvements in interference avoidance by adding channel agility and low latency transmissions to address the specific needs of consumer electronics.

There are two ways to develop a Synkro application: the Synkro API and Synkro BlackBox. The Synkro API allows for application development using the embedded processor running the Synkro protocol. This is the lowest cost solution. The Synkro BlackBox provides access to the complete Synkro API through a serial command set. This alternative allows for application development on a separate processor which enables a more flexible system definition to meet the specific needs of end products.

### ZigBee Supports Green Applications

Since day one, ZigBee technology has been focused on green issues by reducing energy consumption through automation. Among other things, ZigBee technology is ideal for sensing and control of energy consuming devices such as lighting and heating/ventilation/air-conditioning (HVAC) in both home and commercial buildings.

ZigBee Home Area Networks provide intelligent automation in the home, allowing utility companies to reduce peak demand by

### ZigBee® Home Area Network

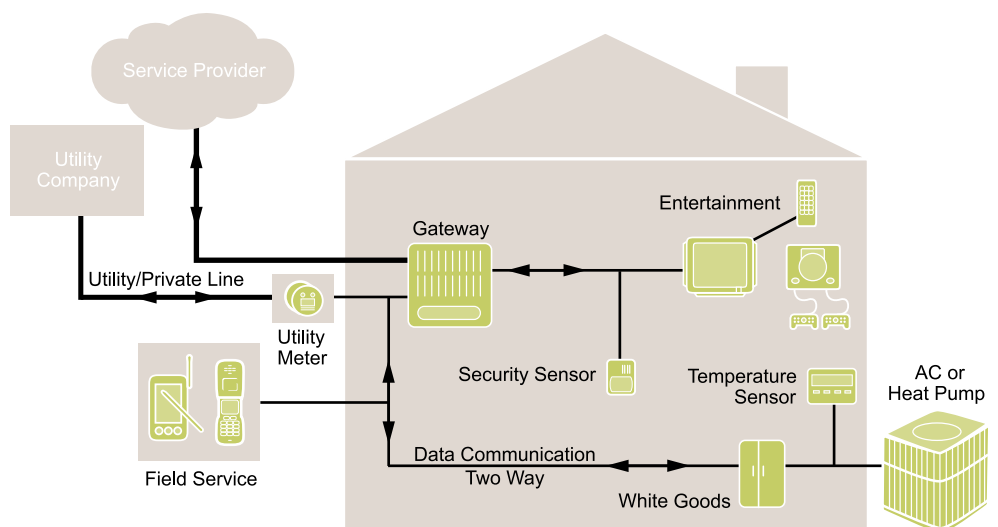

controlling devices such as air conditioning units, while allowing consumers to schedule or turn off devices based on energy rates.

### Freescale's Advantage

Building on our an extensive knowledge of RF semiconductor processes, Freescale offers a wide variety of IEEE 802.15.4-compliant platforms. Freescale's 802.15.4 family, first introduced in 2004, has a proven track record in the market with exceptional RF performance and a flexible architecture.

### MC1320X RF Transceiver

Freescale's MC1320X fully compliant 802.15.4 transceiver includes an integrated TX/RX switch that lowers the component count and system cost while multiple low power modes decrease the system power consumption. These features help make this an ideal solution for cost-sensitive, energy-efficient sensing and control applications. Through an SPI interface, the MC1320X can easily connect with Freescale's vast portfolio of MCUs, including the Flexis™ family of devices.

- Fully compliant 802.15.4, 2.4 GHz transceiver
- Integrated TX/RX switch
- SPI interface to MCU
- 5 x 5 32-pin QFN

### MC1321X System in Package (SiP)

Freescale's MC1321X SiP, integrates the MC13202 2.4 GHz transceiver with the MC9S08GT MCU to provide a single package solution. It provides the benefits of the MC13202 transceiver with a low-power 8-bit MCU to further reduce the size and cost of the solution over a similar 2-chip implementation.

Three flash memory configurations are available to optimize solution costs based on application needs.

- Up to 60 KB flash and 4 KB RAM
  - MC13211: 16 KB flash, 1 KB RAM
  - MC13212: 32 KB flash, 2 KB RAM
  - MC13213: 60 KB flash, 4 KB RAM
- Fully compliant IEEE 802.15.4 platform
- Receive sensitivity of -92 dBm
- 9 x 9 64-pin LGA package

### MC13224 Platform in Package™ (PiP)

Freescale's latest addition has changed the market dynamics for short range wireless ICs. The MC13224 PiP is a quantum leap in reduced power and integration technology, trimming solution size and power consumption by up to 50 percent. A hardware accelerator reduces the load on the CPU, allowing the radio to perform many operations without interrupting the MCU. In addition, a combination of ROM, RAM and flash memory positions this IC as the ideal solution for more complicated networks such as ZigBee technology. The MC13224 PiP integrates performance and simplicity to provide customers with the ultimate platform for 802.15.4 development.

- MC13224—9.5 x 5.5, 99-pin LGA
- Fully compliant IEEE 802.15.4 platform
- -96 dBm to -100 dBm sensitivity
- 0 RF matching component simplifies design while reducing cost
- Hardware acceleration for 802.15.4 functions
- 32-bit ARM7TDMI-S CPU up to 26 MHz
- -40°C to +105°C operating temperature

### SMAC Features

- Small memory footprint
- Supports point-to-point and star networks with repeaters
- Support for over-the-air programming

### IEEE 802.15.4 MAC Features

- Fully compliant IEEE 802.15.4 MAC
- Supports optional features, including beaconed networks and guaranteed time slots (GTS)
- Supports peer-to-peer, star and mesh networks

### Synkro Features

- Lightweight networking stack built on the IEEE 802.15.4 standard
- Approximately 32 KB memory
- For RF control, monitor and automation of consumer electronics products
- Optimized memory with standard command tables
- Two development options:
  - Cost-effective Synkro API using embedded processor running Synkro
  - Synkro BlackBox with complete access to API through serial command set
- Improved interference avoidance capabilities with channel agility and low latency transmissions

### BeeStack Features

- Supports ZigBee 2007
- Supports ZigBee Pro
- Supports Smart Energy Profile
- Supports tree and mesh networks
- Synkro

### Filling in the Gaps

Other standard and proprietary offerings can help fill in the gaps where these may not fit. ISA100.11a and WirelessHART technologies are two examples of 802.15.4-based network stacks targeted specifically for the industrial market. These have been added to enhance 802.15.4 for use in extremely harsh environments. In addition, several proprietary options are available and offer turnkey solutions that simplify development. Many Freescale partners have built solutions based on Freescale's 802.15.4 platforms.

### MC13224 Block Diagram

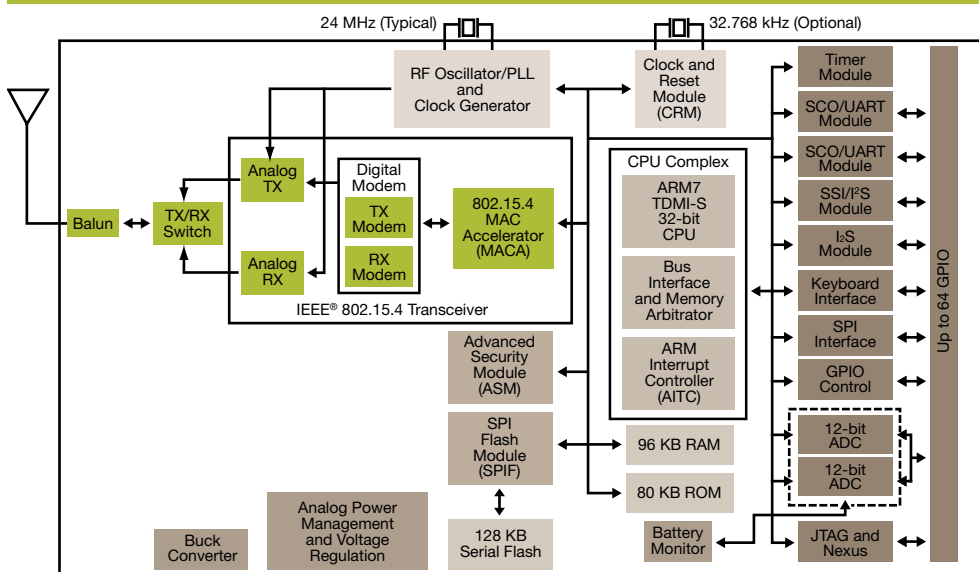

# Microcontrollers and Beyond

The RF transceiver is just one component of Freescale's 802.15.4 platform solutions. A processing device is required to complete the solution when using the MC1320X family of transceivers. In this regard, Freescale offers a vast array of MCUs from 8-bit to 32-bit MCUs, including the revolutionary Flexis series, offering the ultimate in performance migration with pin, peripheral and tool compatibility between 8- and 32-bit MCUs. The Flexis QE series also hosts Freescale's new ultra-low-power technology that dramatically reduces power consumption. Our MCUs provide a number of different processing capabilities along with flexible peripheral and memory combinations to meet specific application needs. Some 8-bit examples include:

- MC9S08GB—32 KB to 60 KB flash memory
- MC9S08GT—8 KB to 60 KB flash memory
- MC9S08QE—4 KB to 128 KB flash memory

Freescale also has developed a family of 802.15.4 compatible sensors, which can easily be incorporated into a wireless network. These sensors are based on micro-electromechanical systems (MEMS) technology and use standard hardware interfaces. Customers can choose from a broad range of sensor solutions, including:

- Acceleration
- Pressure
- Proximity
- Safety and alarm

## Development Tools

Freescale offers a comprehensive development kit that provides customers with the necessary hardware and software to evaluate and develop wireless solutions ranging from simple point-to-point networks to ZigBee mesh networks. The development kits are based on Freescale's 802.15.4-compliant platforms and contain the necessary hardware boards, cables, batteries, power adapters, software and sample applications, providing a fast track for wireless development. In addition, the designer kits are delivered with Freescale's BeeKit Wireless Connectivity Toolkit. The BeeKit provides a simple GUI approach to configure network settings, allowing the development to concentrate on designing the application. BeeKit helps developers without extensive networking experience reduce development time.

## Features

- Hardware development boards
- BeeKit Wireless Toolkit
  - SMAC
  - MAC
  - BeeStack
  - Sample applications
  - Test tool
- Compiler
- Cables, batteries and power adapters
- Out-of-box application
- RoHS compliant

## Optional Features

- Debugger
- Protocol analyzer



**Learn More:** For more information about 802.15.4/ZigBee products, please visit [www.freescale.com/802154](http://www.freescale.com/802154).