

Robotic Arm

Overview

Use of hybrid architecture combining an MPC5xx microcontroller unit (MCU) and two to three *TouCAN™* modules can be used in applications from toys to industrial manufacturing. Each node on a robotic arm application has a stand alone functioning module designed to enable modular construction, leading to adaptable robotic arms. Nodes include sensors designed to gauge temperature, pressure, and position allowing feedback to the central control unit. Up to 32 nodes can be driven from one embedded controller.

The MPC500 embedded microcontrollers are ideal for control intensive applications like the robotic arm. Compatible with the PowerPC ISA instruction set architecture, these devices are available with two or three *TouCAN™* modules capable of sending control signals to CAN drivers (one

for each *TouCAN™* module). The systems communication is essentially achieved between two lines with a CAN 2.0B protocol. Each CAN driver is engineered to be able to drive up to 32 nodes across an entire robotic application. The nodes are designed to independently deliver control commands to motors or actuators, or send and receive sensor information about the robot, or the surrounding environment.

Imagine a cave exploration robot rolling downward into a rough, dark cavern. It examines a rock with a remote controlled arm—scratching the surface and detecting compounds. Next, the robot plunges into a liquid pool. Sensors on the arm inform the central processor the liquid is di-hydrous oxide (water) and proceeds to the next observation.

Key Benefits

- > MPC500 embedded microcontrollers are ideal for control-intensive applications like the robotic arm
- > Compatible with the PowerPC™ ISA instruction set architecture
- > Features CAN 2.0B (*TouCAN™*) for system control
- > Available in 125 kbps for simple control (repetitive acts of part movement from point A to B in a production line) and in 250 kbps or 500 kbps for complex control for use in mobile machinery moving through various environments and requiring many sensor feedbacks from numerous sources

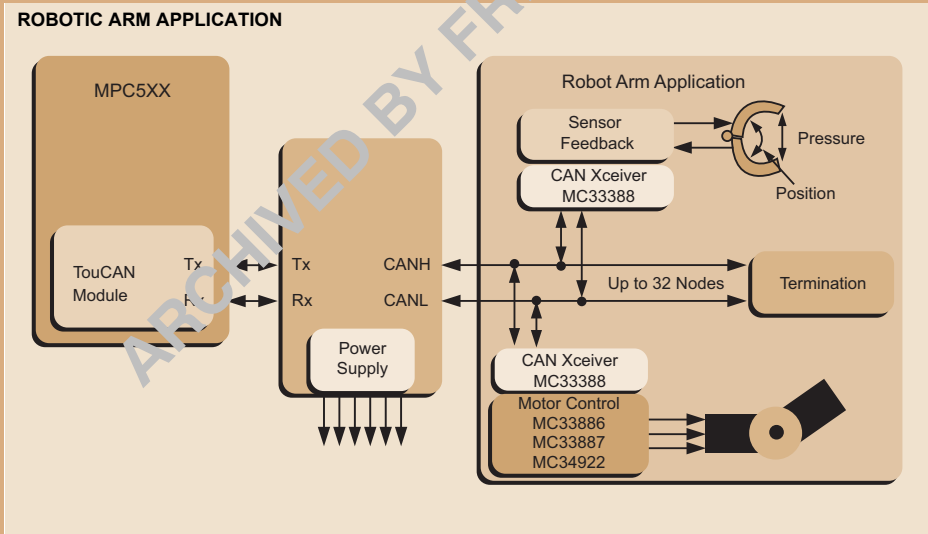

Freescale Ordering Information^{Note}

| Part Number | Product Highlights | Additional Information |
|------------------|---|--|
| DSP56F800 Family | 80 MHz, 40 MIPS, up to 31.5 KB Flash, 6 K words RAM and Off-Chip Memory; SCI, SPI, ADC, PWM, Quadrature Decoder, Quad Timer, CAN, and GPIO; MCU-Friendly Instruction Set; JTAG/OnCE for Debug | www.freescale.com |
| MC33388 | Fault Tolerant CAN Interface | www.freescale.com/analog |
| MC33886 | H-Bridge Driver (5.2 A) | |
| MC33887 | H-Bridge Driver with Sleep Mode (5.2 A) | |
| MC34922 | Dual Power H-Bridge (4.0 A) | |
| MC56F8300 Family | 60 MHz, 60 MIPS, up to 576 KB Flash, 36KB RAM and Off-Chip Memory; SCI, SPI, ADC, PWM, Quadrature Decoder, Quad Timer, <i>FlexCAN</i> [™] , GPIO, COP/Watchdog, and PLL; MCU-Style Software Stack Support; JTAG/OnCE for Debug; Temperature Sensor | www.freescale.com |
| MPC500 | Floating Point Unit; 40 or 56 MHz CPU; Compatible with PowerPC ISA; Available with Code Compression; Up to 1 MB Flash Memory | |

Note: Search on the listed part number.

ARCHIVED BY FREESCALE SEMICONDUCTOR INC.

Design Challenges

Design challenges for robotic manipulations include boundary control, strength of movement, and intricate interaction between various parts of one arm, or dual robotic arms, working together. Boundary control and controlling the force applied to the movement is essential for safety and proper motion of a robotic arm. This can be assisted with the use of the queued analog-to-digital converter (QADC) modules. Intricate timing of interactions can be assisted with the use of the timer processor unit (TPU) modules. Timely communication of these and other controls may be achieved through the *TouCAN™* modules. All of these modules are a part of Freescale Semiconductor's MPC500 family.

Freescale Semiconductor Solution

The robotic arm features Controller Area Network (CAN) 2.0B (*TouCAN™*) for system control. It is available in 125 kbps for simple control such as repetitive acts of part movement from point A to B in a production line. It is also available in 250 kbps or 500 kbps for complex control for use in mobile machinery moving through various environments requiring many sensor feedbacks from numerous sources. An example of this functionality might be in a vehicle such as a submersible cave explorer with exploration arms. The arms could provide feedback about texture, hardness, and grip.

Line termination is a requirement of the system for it to function properly. It is important for the customer to know about line termination to remove the mystery *physics* required to operate the system.

This requirement is achieved in one of three ways:

- > A 60 Ω resistor across CANH and CANL
- > Two 120 Ω resistors at each end across CANH and CANL and a 30 Ω resistor from CANH
- > One 30 Ω resistor from CANL with a capacitor between the resistors

Freescale Semiconductor offers the MPC500 embedded microcontrollers featuring three *TouCAN™* controllers on each MPC500 part (two on the MPC555). This connectivity provides the customer with a higher degree of freedom when developing the final application. Several operations can be run in parallel or can be independently segmented from the rest of the system to operate under unique parameters. Additionally, it offers a 2.0B CAN protocol and much more.

ARCHIVED BY FREESCALE SEMICONDUCTOR

Development Tools^{Note}

| Vendor | MPC555 | MPC561 | MPC562 | MPC563 | MPC564 | MPC565 | MPC566 | MC56F8300 | TPU |
|--|--------|--------|--------|--------|--------|--------|--------|-----------|-----|
| Metrowerks | | | | | | | | | |
| CodeWarrior™ for PowerPC Embedded Systems | • | • | • | • | • | • | • | | |
| CodeWarrior for OSEK RTOS | • | • | • | • | • | • | • | | |
| CodeWarrior Development Systems | • | | | | | • | | • | |
| OSEKturbo (RTOS) | • | • | | • | | • | | • | |
| TPU Low-Level Driver Library | | | | | | | | | • |
| Flash Programming — CodeWarrior for Embedded PowerPC | • | | | • | • | • | • | • | |
| Flash Programming — CodeWarrior for OSEK RTOS | • | | | • | • | • | | • | |
| Wind River Systems | | | | | | | | | |
| BDM Debugger — SingleStep | • | • | | • | | | | | |
| BDM Debugger — SingleStep with Vision | • | • | | • | | | | | |
| Flash Programming — SingleStep | • | | | • | | • | | | |
| BDM Debugger — VisionCLICK | • | • | | • | | • | | | |
| Nexus Debugger — VisionCLICK | | • | | • | | • | | | |
| Nexus Debugger — SingleStep with Vision | | • | | • | | • | | | |
| Flash Programming — VisionCLICK | • | | | | | • | | | |
| Compiler — DiabData | • | • | • | | • | • | • | | |
| MATRIXx | • | • | • | • | | • | | | |
| Simulator — SingleStep | • | • | | • | • | • | • | | |
| Lauterbach | | | | | | | | | |
| BDM Debugger Trace32 | • | • | • | • | • | • | • | • | • |
| Nexus Debugger Trace32 | | • | • | • | • | • | • | | • |
| Code Trace (with Bus access) | • | | • | • | • | • | • | | |
| Code Trace (Nexus) | • | • | • | • | • | • | • | • | |
| Axiom Manufacturing | | | | | | | | | |
| Low-Cost Evaluation Board | • | • | | | | | | | |
| Mid-Range Evaluation Board | • | • | | | | | | | |
| Full-Feature Evaluation Board | • | • | • | • | • | • | • | | |
| Ashling Microsystems | | | | | | | | | |
| BDM Debugger — Opella, Genia, and Vitra | • | • | • | • | • | • | • | | |
| Nexus Debugger — Vitra (w/trace) | | • | | • | | • | | | • |
| Nexus Debugger — Opella/Genia | | • | | • | | • | | | |
| Green Hills Software | | | | | | | | | |
| IDE, Debugger — VxWorks | • | • | | • | | • | | | |
| Compiler — C/C++/EC++ | • | • | | • | | • | | | |

Note: Search on the product name.

Disclaimer

This document may not include all the details necessary to completely develop this design. It is provided as a reference only and is intended to demonstrate the variety of applications for the device.

Development Tools (continued)^{Note}

| Tool Type | Product | Vendor | Description | Additional Information |
|----------------|----------------|-------------------------|---|------------------------|
| Software | CW568X | Freescale Semiconductor | CodeWarrior Development Studio for 56800/E Controllers with Processor Expert (Metrowerks) | www.freescale.com |
| Hardware | 56F800DEMO | Freescale Semiconductor | 56F800 Demonstration Kit | |
| Hardware | DSP56F801EVM | Freescale Semiconductor | Evaluation Module for the 56F801 | |
| Hardware | DSP56F802EVM | Freescale Semiconductor | Evaluation Module for the 56F802 | |
| Hardware | DSP56F803EVM | Freescale Semiconductor | Evaluation Module for the 56F803 | |
| Hardware | DSP56F805EVM | Freescale Semiconductor | Evaluation Module for the 56F805 | |
| Hardware | DSP56F807EVM | Freescale Semiconductor | Evaluation Module for the 56F807 | |
| Hardware | MC56F8300DSK | Freescale Semiconductor | 56F8300 Developers Start Kit | |
| Hardware | MC56F8323EVM | Freescale Semiconductor | Evaluation Module for 56F8322 and 56F8323 | |
| Hardware | MC56F8367EVM | Freescale Semiconductor | Evaluation Module for the 56F834x, 56F835x and 56F837x | |
| Evaluation Kit | KIT33388DEVB | Metrowerks | Fault Tolerant CAN Interface | www.metrowerks.com |
| Evaluation Kit | KIT33886DHEVB | Metrowerks | H-Bridge Integrated Circuit | |
| Evaluation Kit | KIT33887DWBEVB | Metrowerks | 225 mΩ 150°C and Sleep Mode and Current Sense | |
| Evaluation Kit | KIT34922PNAEVB | Metrowerks | Dual H-Bridge with Load Current Feedback | |

Note: Search on the product name.

Freescale Semiconductor Reference Designs^{Note}

| Design Number | Description | Additional Information |
|---------------|--|------------------------|
| RD68HC908RKE | Radio Frequency Reference Design for Remote Keyless Entry Radio frequency is an ideal wireless technology for low-cost applications where users only need to transmit data. There are many uses for RF technology such as in gate openers, smoke detectors, and remote sensors for a variety of consumer and industrial products. | www.freescale.com |
| RD68HC08PIR | Passive Infrared (PIR) for Security Peripherals and Other Remote Networks The self-calibrating PIR detector reference design demonstrates the ability of a device from the 68HC08P/L/J/K family of MCUs to form the core of an intelligent PIR detector that is capable of self-calibration and walk-through test from data provided by a handheld remote control unit communicating via an infrared protocol. The remote control unit is also to be implemented using an MC68HC908GP32. | |

Note: Search on the listed design number.

Related Documentation^{Note}

| Document Number | Description | Additional Information |
|-----------------|--|------------------------|
| APDPAK | Analog ICs Integrated Solutions Pitch Pack | www.freescale.com |
| SG1002 | Analog Product Selector Guide | |

Note: Search on the listed document number.

Notes

ARCHIVED BY FREESCALE SEMICONDUCTOR INC.

Learn More: Contact the Technical Information Center at +1-800-521-6274 or +1-480-768-2130.
For more information about Freescale products, please visit www.freescale.com.

Freescale™ and the Freescale logo are trademarks of Freescale Semiconductor, Inc.
All other product or service names are the property of their respective owners.
© Freescale Semiconductor, Inc. 2005. All rights reserved.

SG2076
REV 3
6/2005

June2005

