

Digitally Controlled Electronic Lighting Ballast

Overview

A lighting system in a typical building, based on ballasts that use a simple inductor and starter, can consume up to 40 percent of the electricity required to power the building. This inefficiency is wasteful and costly.

The introduction of new European and International legislation is mandating increased efficiencies and the elimination of the two most inefficient light ballasts from 2005.

The deadline for this conversion is driving the development of efficient, cost-effective electronic light ballasts. Microcontrollers offer the ideal low-cost solution.

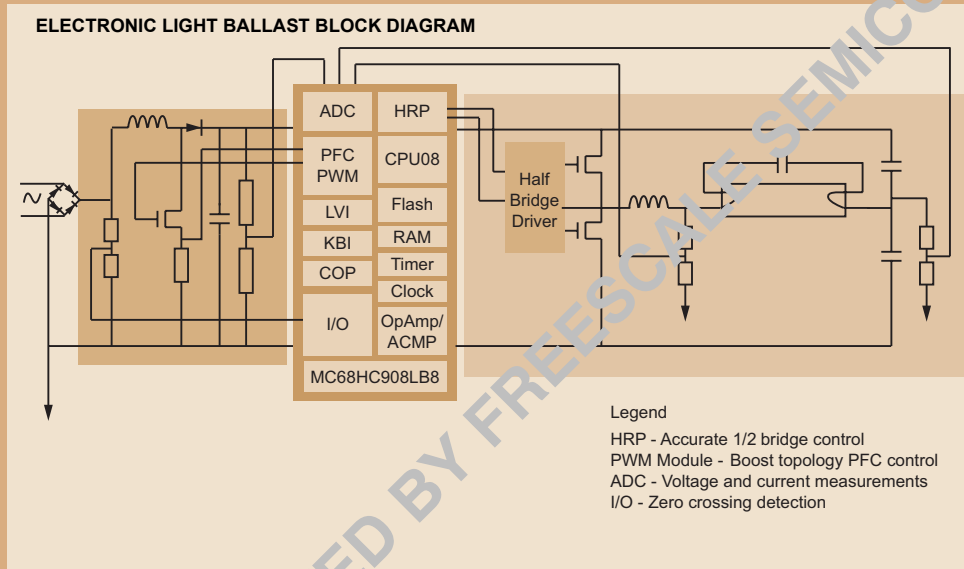

Key Benefits

- > Electronic ballasts offers increased system efficiency over traditional magnetic ballasts.
- > Improved ballast efficiency leads to extended life for fluorescent tubes.
- > Electronic systems provide an increased level of control for variable light levels.
- > Digital control allows large lighting networks to be controlled remotely.
- > The DALI protocol provides intelligent building automation and cost-effective large lighting network control.
- > Complete reference designs, based on Freescale Semiconductor MCUs, are available from Freescale Semiconductor free of charge.

Freescale Ordering Information

Part Number	Product Highlights	Additional Information
MC68HC908LB8	CPU08, 8K bytes of on-chip FLASH, 128 Bytes RAM, ADC, High Speed PWM and PWM with Fault Input, 16-Bit Timer and Integrated Op-Amp	In-circuit programmable Flash memory, Flash program memory Security. Available in 20-pin SOIC and PDIP.
MC68HC908KXx	CPU08, up to 8K bytes of on-chip FLASH, 192 Bytes RAM, ADC, PWM, 16-Bit Timer and SCI	In-circuit programmable Flash memory, Flash program memory Security. Available in 16-pin SOIC and PDIP.
MC68HC908QYx	CPU08, Up to 4K bytes of on-chip FLASH, Up to 128 Bytes RAM, ADC ^{Note} , 16-Bit Timer	In-circuit programmable Flash memory, Flash program memory Security. Available in 16-pin SOIC, PDIP, and TSSOP.
MC68HC908QTx	CPU08, Up to 4K bytes of on-chip FLASH, Up to 128 Bytes RAM, ADC ^{Note} , 16-Bit Timer	In-circuit programmable Flash memory, Flash program memory Security. Available in 8-pin SOIC, PDIP, and DFN.
DSP56F801	80 MHz, 40 MIPS, SCI, SPI, ADC, PWM, Quad Timer and 8K Program Flash, 1K Program RAM, 2K Data Flash, 1K Data RAM	MCU-friendly instruction set, OnCE for debug, on-chip relaxation oscillator, 2K BootFLASH and up to 11 GPIO available in a 48-pin LQFP.
DSP56F802	80 MHz, 40 MIPS, SCI, SPI, ADC, PWM, Quad Timer and 8K Program Flash, 1K Program RAM, 2K Data Flash, 1K Data RAM	MCU-friendly instruction set, OnCE for debug, on-chip relaxation oscillator, 2K BootFLASH and up to 4 GPIO available in a 32-pin LQFP.

Note: ADC only on some derivatives.

Design Challenges

A lighting ballast that uses a simple inductor and starter consumes 40 percent of electricity required to power a building. The inefficiency is wasteful and costly.

Freescale Semiconductor Solutions

The MC68HC908LB8 from Freescale provides the ideal one chip solution for light ballast applications, offering reduced component count, significant cost-saving, and improvements in system efficiency. A complete reference

design is available based on the MC68HC908LB8 demonstrating dimmable light ballast control with power factor correction.

This device also supports the DALI protocol which provides intelligent building automation and cost-effective lighting network control. A complete DALI reference design based on the Freescale MC68HC908KX8 is also available.

Many of our other standard microcontrollers, including the

MC68HC908Q family detailed above, offer attractive low cost solutions as part of a multi-chip system.

Benefits Using MC68HC908LB8

- > Reduces power loss and distortion by addressing power factor correction.
- > Accurately controls signals using high resolution PWM.
- > High integration reduces system size and cost.
- > Complies with energy efficiency requirements for ballast in fluorescent lighting systems; directive IEC 555.

Development Tools

Tool Type	Product Name	Vendor	Description
Demo Board	DEMO908LB8	Freescale Semiconductor	Cost effective development board in a small form factor with serial port, switches, LEDs, potentiometer, and demo software including source code.
Emulation Module	M68EML03LB8	Freescale Semiconductor	Emulation module for FSICE system.
Emulation Kit	FSICEKITLB8	Freescale Semiconductor	Complete FSICE high-performance emulator kit; includes emulator module, cables, head adapters, and programming adapters.
Demo Board	M68DEMO908QT4	Freescale Semiconductor	Low-cost demo board for M68HC908Qx.
Emulation Module	M68EML08QBLTY	Freescale Semiconductor	Microcontroller emulation module for use with FSICE.
Emulation Kit	FSICEKITQBLTY	Freescale Semiconductor	Complete FSICE high-performance emulator kit; includes emulator module, cables, head adapters, and programming adapters.
Hardware	56F800DEMO	Freescale Semiconductor	56F800 Demonstration Kit
Hardware	DSP56F801EVM	Freescale Semiconductor	Evaluation module for 56F801 and 56F802 processors.

Third Party Support

Vendor	Description	Contact Information
Metrowerks	CodeWarrior™ Development Studio for 56800/E Hybrid Controllers and HC(S)08.	www.metrowerks.com
P&E Microcomputer Systems	Windows Upgrades for Simulator Software for 68HC08.	P.O. Box 2044 Woburn, MA 01888 http://www.pemicro.com Phone 617-353-9206 Fax 617-353-9205

Freescale Semiconductor Reference Designs

Design Number	Description	Contact Information
RDHC908LB8LIGHT	Dimmable Light Ballast with Power Factor Correction Reference Design The drive for energy conservation and the resulting legislation has led to a need for more efficient light ballast design. This reference design describes the design of a fully digital dimmable light ballast with power factor correction (PFC) control for two parallel connected fluorescent lamps.	www.freescale.com ^{Note}
RDHC908KX8DALI	Digital Addressable Lighting Interface (DALI) for Lighting Networks Reference Design The drive for energy conservation and intelligent building automation has led to the development of the DALI standard for control of lighting networks, especially those involving fluorescent ballasts. Backed by the major lighting manufacturers in the world, the DALI interface allows for low-cost control of large networks. This design demonstrates how to use the Freescale Semiconductor 68HC908KX8 in a master-slave configuration where the units are communicating with a simple protocol.	www.freescale.com ^{Note}

Note: Search on the listed design number.

ARCHIVED BY FREESCALE SEMICONDUCTOR INC.

Notes

ARCHIVED BY FREESCALE SEMICONDUCTOR INC.

Learn More: Contact the Technical Information Center at +1-800-521-6247 or +1-480-768-2130.
For more information about Freescale products, please visit www.freescale.com.

Freescale™ and the Freescale logo are trademarks of Freescale Semiconductor, Inc.
All other product or service names are the property of their respective owners.
© Freescale Semiconductor, Inc. 2005. All rights reserved.

SG2068
REV 6
04/2005

April2005

