

Energy Meter

Overview

The difficulty in balancing functionality and performance against cost and reliability has prevented wider use of electronic energy meters. A combination of digital signal processors (DSPs) and analog-to-digital

converters (ADCs) allows high metering accuracy. Incorporating both a microcontroller unit (MCU) and a DSP on a single chip reduces the cost while simplifying the solution.

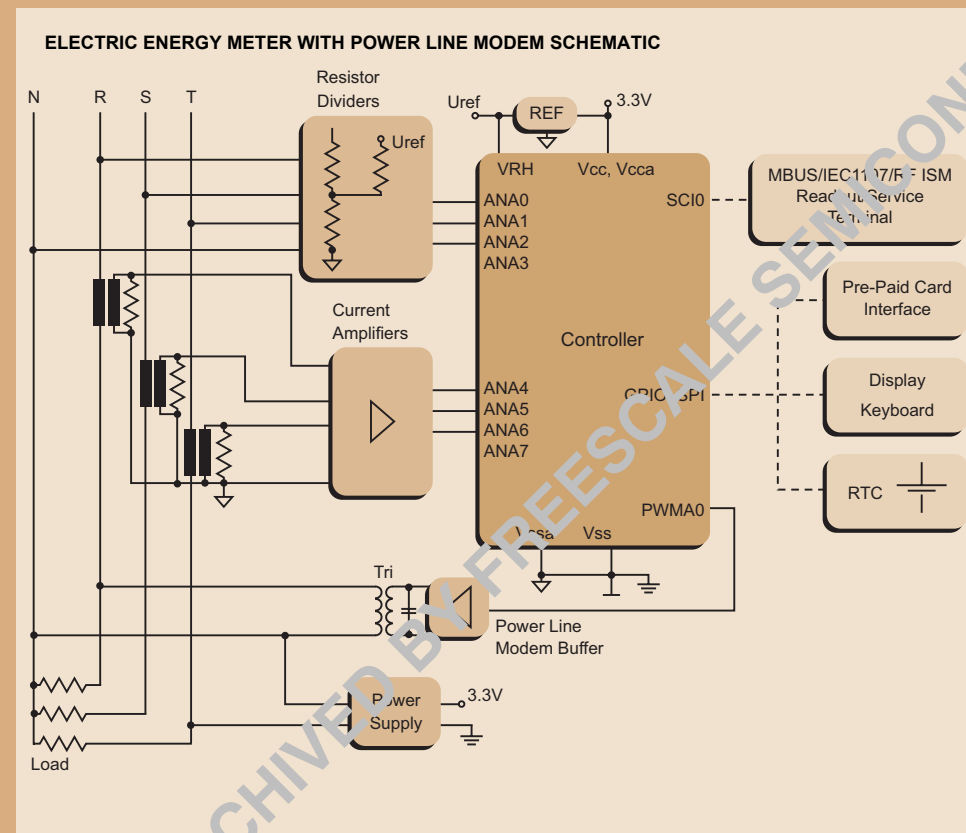

Key Benefits

- > Incorporates MCU and DSP on a single chip to enhance functionality and performance while reducing costs
- > Computes more electric parameters than electromechanical and simpler electronic meters
- > Provides high measuring accuracy with nonlinear loads
- > Digital Signal Controller (DSC) enables power line modem functionality, which is carried out in software
- > Configurable for single-, dual-, and three-phase energy metering
- > Out-of-the-box software components designed to expedite time-to-market and reduce development costs

Because of an order from the United States International Trade Commission, BGA-packaged product lines and part numbers indicated here currently are not available from Freescale for import or sale in the United States prior to September 2010: DSP56F807VF80, DSP56F807VF80E

Freescale Ordering Information

Part Number	Product Highlights	Additional Information
MC56F8100 Family ^{Note}	40 MHz, 40 MIPS, up to 544KB Flash, 32KB RAM and Off-Chip Memory, SCI, SPI, ADC, PWM, Quadrature Decoder, Quad Timer, FlexCAN, GPIO, COP/Watchdog, PLL, MCU-style software stack support, JTAG/OnCE for debug	www.freescale.com
MC56F8300 Family	60 MHz, 60 MIPS, up to 576KB Flash, 36KB RAM and Off-Chip Memory, SCI, SPI, ADC, PWM, Quadrature Decoder, Quad Timer, FlexCAN, GPIO, COP/Watchdog, PLL, MCU-style software stack support, JTAG/OnCE for debug, temperature sensor	www.freescale.com
DSP56F800 Family	80 MHz, 40 MIPS, up to 31.5KB Flash, 6K words RAM and Off-Chip Memory, SCI, SPI, ADC, PWM, Quadrature Decoder, Quad Timer, CAN GPIO, MCU-friendly instruction set, JTAG/OnCE for debug	www.freescale.com
MC56F801x Family	Up to 32 MHz, 32 MIPS, and up to 16KB Flash, 4KB Unified Data/Program RAM, EEPROM emulation capability, SCI with LIN, SPI, I ² C, ADC, PWM, GPIO, COP/Watchdog, MCU-style software stack support, JTAG/OnCE for debug	www.freescale.com

Note: MC56F8122 and MC56F8123 are not appropriate for this application.

Design Challenges

The functionality and the performance of an electronic energy meter outperform those of the traditional Ferraris wheel meter. One advantage of an electronic meter in monitoring nonlinear loads is its high metering accuracy—electronic measurements are more robust and accurate. Cost and reliability are the main obstacles blocking the electronic energy meter's wider use. To be more attractive to customers, the electronic meter must offer either more functionality or the cost must be decreased near the level of electromechanical solutions.

Freescale Semiconductor Solution

The Digital Signal Controllers from Freescale Semiconductor are fully versatile for a high-performance, low-cost, single-chip energy meter with many additional features not found in other solutions.

A DSC-based meter can compute many electric parameters including:

- > Active power and energy
- > Reactive power and energy
- > Apparent power and energy
- > Computations of maximum demands (peak power) and archival
- > Multiple tariff counters
- > Record management system (RMS) value of phase voltages and phase currents
- > Frequency power factor
- > Higher harmonics analysis

Among the most important of the controller's peripherals are the 2 x 4 channel fast simultaneous sampling 12-bit analog-to-digital converter (ADC), pulse width modulator (PWM), general purpose ports, timers, Flash memory, and microcontroller functionality at 40 MIPS. On-chip Flash is page-erasable and can be used more inexpensively than traditionally used EEPROMs.

The DSC can be implemented as a power line modem. The modem's receive function uses the same voltage samples used for power computation. The transmit function uses an integrated PWM peripheral, followed by a buffer connected to the one power phase.

The on-chip ADC is capable of simultaneous dual sampling, allowing current and voltage to be sampled together in each phase. Energy computations consist mainly of multiplication and addition operations, which are easily handled by this DSC. The high ADC sampling rate (up to two samples at 830 kHz) contributes to high measuring accuracy even with nonlinear loads.

Phase voltages are scaled down to the range of the ADC by resistor dividers. They bias the zero-level input voltage to the middle of the ADC's range. The phase current is measured by current transducers, while the input level is amplified by inverting operational

amplifiers (OPAMs). Depending on current transducer type, software correction of the phase shift may be necessary before energy computation.

The power line modem is enabled in software. The digital signal controller is powerful enough to operate filters, demodulators, transmit modulators, and other necessary functions simultaneously with energy computations. The only additional component is a power line interface buffer with transformer. The buffer consists of a simple totem pole transistor stage. The transformer is mainly used to isolate high voltage. Primary winding coupled with a capacitor resonance circuit performs transmit post-filtering. These parts should be adapted according to the modulation scheme used. Appropriate modulations for this purpose are Frequency Shift Keying (FSK) in the frequency range 125–140 kHz, as specified by the European Committee for Electrotechnical Standardization (CENELEC), or below 450 kHz, as specified by the Federal Communications Commission (FCC). Data rate is 1200–2400 bps, sufficient for data collection from meters. For higher data rates, a more sophisticated modulation scheme should be used.

The figure on page 1 depicts a complete three-phase energy meter on the DSC. A similar schematic can be used for single- or dual-phase meters by omitting unnecessary current transducers and voltage dividers.

Description of the optional blocks shown on page 1 include:

- > **Display, keyboard.** Can be connected through general purpose input/output (GPIO) pins or through serial peripheral interface (SPI)
- > **Readout/service terminal.** M-BUS cable interface or RF interface connected through serial communications interface 0 (SCI0) (universal asynchronous receiver and transmitter, or UART)
- > **Prepaid card interface.** For energy delivery based on prepaid cards
- > **RTC.** A real-time clock for data logging time stamps and multi-tariff billing

Development Tools

Tool Type	Product Name	Vendor	Description
Software	Processor Expert	Freescale Semiconductor	Software infrastructure that allows development of efficient, high-level software applications that are fully portable and reusable across all 56800/E family of processors.
Software	CWDSP56800	Freescale Semiconductor	CodeWarrior Software Development Tools for DSP56800 (Metrowerks)
Hardware	56F800DEMO	Freescale Semiconductor	56F800 Demonstration Kit
Hardware	DSP56F801EVM	Freescale Semiconductor	Evaluation Module for the DSP56F801 and DSP56F802
Hardware	DSP56F803EVM	Freescale Semiconductor	Evaluation Module for the DSP56F803
Hardware	DSP56F805EVM	Freescale Semiconductor	Evaluation Module for the DSP56F805
Hardware	DSP56F807EVM	Freescale Semiconductor	Evaluation Module for the DSP56F807
Hardware	MC56F8367EVM	Freescale Semiconductor	Freescale Semiconductor Evaluation Module for 56F834x, 56F835x, 56F836x
Hardware	DEMO56F8013	Freescale Semiconductor	Demonstration kit for the 56F8013
Hardware	DEMO56F8014	Freescale Semiconductor	Demonstration kit for the 56F8014
Development Kit	DSPOSRTOS	Freescale Semiconductor	Emulation Support for DSP56F8xx Processors (Requires Ethernet Network)

Disclaimer

This document may not include all the details necessary to completely develop this design. It is provided as a reference only and is intended to demonstrate the variety of applications for the device.

Notes

ARCHIVED BY FREESCALE SEMICONDUCTOR INC.

Learn More: Contact the Technical Information Center at +1-800-521-6274 or +1-480-768-2130.
For more information about Freescale products, please visit www.freescale.com.

Freescale™ and the Freescale logo are trademarks of Freescale Semiconductor, Inc.
All other product or service names are the property of their respective owners.
© Freescale Semiconductor, Inc. 2005. All rights reserved.

SG2067
REV 2
6/2005

June2005



Because of an order from the United States International Trade Commission, BGA-packaged product lines and part numbers indicated here currently are not available from Freescale for import or sale in the United States prior to September 2010: DSP56F807VF80, DSP56F807VF80E