

Proximity Sensing White Paper

Proximity Capacitive Sensor Technology for Touch Sensing Applications

By Bryce Osoinach, Systems and Applications Engineer



Contents

Introduction	3
Proximity Capacitive Sensor Overview	4
Capacitance Sensors in Touch Sensing Applications	5
Additional Applications for Proximity Capacitive Sensors.....	8
Multiple Electrodes and Shield Drive Technology.....	9
Conclusion	11

Introduction

In 1831 Michael Faraday discovered electro-magnetic induction. Essentially, he found that moving a conductor through a magnetic field creates voltage that is directly proportional to the speed of the movement—the faster the conductor moves, the higher the voltage. Today, inductive proximity sensors use Faraday’s Law of Electromagnetic Induction to detect the nearness of conductive materials without actually coming into contact with them. The primary deficiency of these sensors, however, is that they only detect metal conductors and different metal types can affect the detection range.

Proximity capacitive sensors, on the other hand, adhere to the same principle but can detect anything that is either conductive or has different dielectric properties than the sensor’s electrodes’ surroundings. Proximity capacitive sensors have become increasingly popular as more user/machine interfaces are designed using touch panels to reliably respond to commands. Freescale’s advanced MPR083 and MPR084 proximity capacitive touch sensor controllers can be used to replace switches and buttons on a wide variety of control panel applications. The MPR083 device supports an 8-position rotary interface while the MPR084 device controls up to 8 touch pads.

Proximity Capacitive Sensor Overview

Proximity capacitive sensing is a technology that enables touch detection by measuring capacitance, exhibiting a change in capacitance in response to a change in surrounding materials. Certain sensors gauge the change by generating an electric field (e-field) and measuring the attenuations suffered by this field. Unlike inductive sensors, a proximity capacitive sensor can detect anything that is either conductive or has different dielectric properties than the sensor's electrodes' surroundings. They are excellent touchpad enablers because we, humans, being mostly water, have a high dielectric constant, and we contain ionic matter, which makes us good electric conductors.

Freescale uses multiple technologies in its proximity capacitive sensors. The portfolio of MC33794, MC33941 and MC34940 products contains oscillator circuitry in the sensor integrated circuit (IC) to generate a high purity, low frequency 5V sine wave, tunable by an external 39k ohms load resistor. This AC signal is fed to a multiplexer, which directs the signal to a selected electrode or reference pin or to an internal measurement node. The IC automatically connects the unselected nodes to the circuit ground, and these act as the return path needed to create the e-field current.

When an object is brought close to a metal electrode, for instance a finger from our highly dielectric and conductive human subject, an electric path is formed, producing a change in the e-field current. Normally, the sensor measures the AC impedance of the generated e-field and translates that measurement into a DC output voltage. An external microcontroller with an analog-to-digital controller (ADC) then processes this information to perform any number of functions, such as those that are associated with a touchpad control panel. However, our more advanced MPR083 and MPR084 proximity capacitive touch sensor controllers generate digital output through an inter-integrated circuit (I²C) with custom addressing, thus eliminating the need for an external ADC.

Figure 1: Proximity Capacitive Sensor E-field Concept

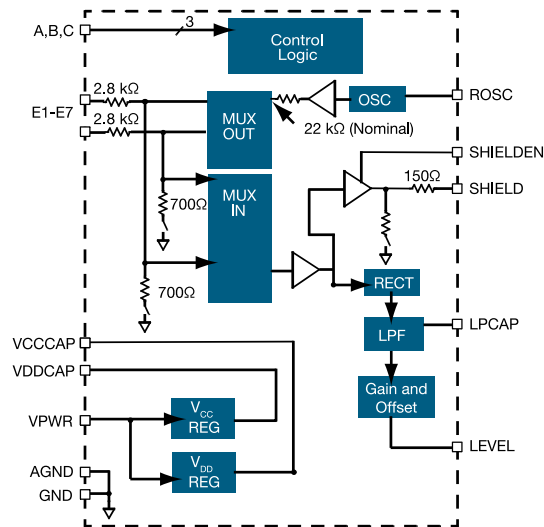

This method of measurement involves RC oscillator technology that uses a GPIO to detect precise voltage change. The GPIO will transition from low to high at 0.5x V_{dd}, and touch detection is achieved by measuring the delay. Benefits of the MPR08X portfolio include lower power consumption and added intelligence, with the sensor algorithm optimized for specific microcontrollers. The devices and software are highly configurable, and the control is optimized for specific sensor layout designs. Timing is controlled through the registers to achieve precise power mode control for lower power consumption.

Proximity capacitive touch sensing is quickly becoming a favorite among designers due to the increased reliability (no moving parts), greater design freedom and a more contemporary look.

Capacitance Sensors in Touch Sensing Applications

Proximity capacitive sensing technology is finding application in a wide variety of industrial and consumer products. The MPR083 and MPR084 devices offer designers a cost-effective alternative to mechanical push-buttons and switches for control panel applications. Both utilize touchpad technology, though in differing form factors.

Touchpad—This is simply a contactless “area” which detects the presence or absence of a finger. The raw detection output is a single bit giving a touch condition. There are three important considerations when developing a touch panel:

1. Touch pad electrode design and layout
2. The different dielectric materials for the surface of the panel
3. The effect on e-field measurements of various environmental conditions

The relationships among these three considerations are described in the following equation.

Figure 2: Capacitor Model

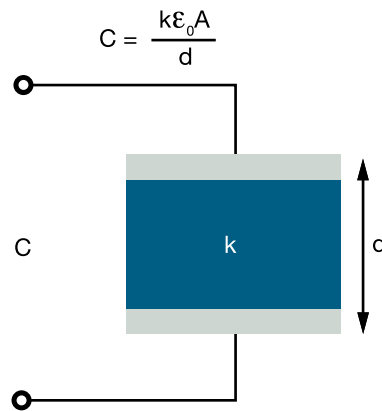

C = capacitance in farads (F)
A = area of the plates in square meters (m²)
d = distance between the plates in meters (m)
k = dielectric constant of the material separating the plates
 ϵ^0 = is the permittivity of free space (8.85×10^{-12} F/m)

The interaction between electrode size and spacing affects the ability to sense objects in the third dimension [Fig. 3]. Larger electrodes have greater range and sensitivity, however, they are more susceptible to interference, electrical noise and stray electric-field paths in its surroundings. Similarly, a greater space between the electrodes generates a larger e-field but weakens the signal. In the case of a touch panel application, the touch pads need only accommodate the tip of a finger, limiting the usable size of the electrodes and the spaces between them.

Figure 3: Proximity Capacitive Touch Sensor Types

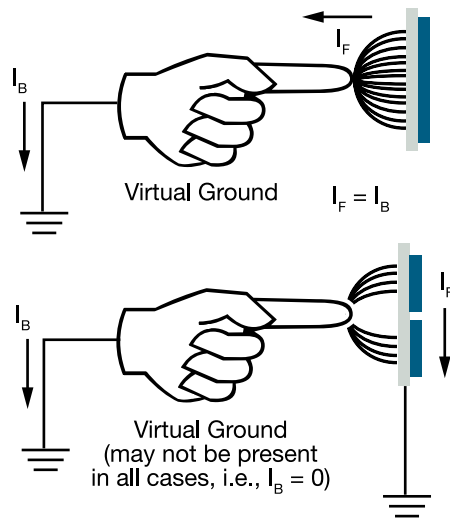

Single Electrode

- E-field is between finger and charged electrode
- Assumes finger is connected to a virtual ground

Multiple Electrodes

- One charged electrode, other at ground
- A very weak field between electrode and ground exists without finger
- As finger approaches electrode, it provides two conductive paths from electrode to ground ($I_F + I_B$)

The effectiveness of the dielectric materials used for the surface of the panel relies on its thickness and its dielectric constant (k). Generally, the insulator over the touch pads should be as thin as possible with as high a dielectric constant as possible. However, the dielectric constant of a thick pad covering may increase as it is compressed, which means neoprene rubber, for example, may actually provide more sensitivity than would normally be expected.

Environmental effects must also be considered when designing a touch panel application. Whereas oil from the fingertip is not likely to have a significant effect, water can affect adjacent touch pads, probably due to the higher current path from the finger to the other electrodes provided by the water's high dielectric constant. Wider separation of the touch pads can mitigate the effect, and designing the application so that water does not collect on the touch pads can also help, particularly for outdoor applications.

As touch panel displays age, temperature and humidity can eventually degrade capacitor performance. The design of the proximity capacitive sensor, however, can compensate for this. For instance, Freescale's sensor technology relies on two reference inputs, one connected to a capacitor with a capacitance near the expected maximum while the other is connected to a capacitor with near the expected minimum capacitance. These reference capacitances can be used to correct environmentally induced errors in the electrode measurements or other component related changes.

The MPR084 proximity capacitive touch sensor controller can control up to 8 touchpads for touch panel control interfaces in a wide variety of applications. These include:

- Appliances
- PC peripherals
- Access controls
- MP3 players
- Remote controls
- Mobile phones

It uses the I²C interface to communicate with the host controller, which configures the operation, and an interrupt to advise the host of status changes. It also features 41 micro-amp (μA) average supply current with monitoring for all touch pads, proprietary false touch rejection technology and even a piezo sounder drive that provides optional audible feedback to simulate mechanical key clicks.

Figure 4: MPR084 Block Diagram

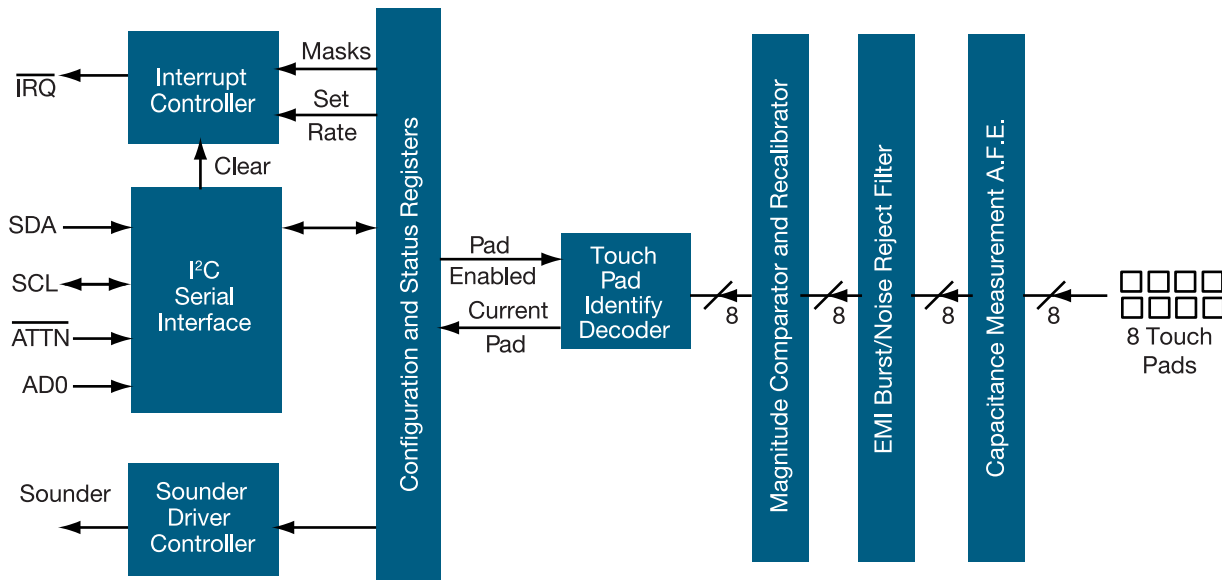

The rotary touch wheel is simply a group of touchpads arranged in a ring. (See Figure 5) The touch wheel not only detects the presence or absence of a finger but also the position of the finger along the surface of the wheel. This surface is defined by the area between the inner and outer circumferences of the rotary wheel.

The MPR083 proximity capacitive touch sensor controller can control an 8-position rotary touch wheel as well as a linear slider application. A capacitive slider is an elongated touch pad that can detect the finger's position along the length of the slider. The raw detection output is a single bit giving touch condition plus a multi-bit word for position. Volume control is a typical application for a capacitive slider.

The MPR083 device shares the same features as the MPR084 touch sensor controller, including a common pin-out, which simplifies management of control panels, switch replacements, rotary and linear sliders and touchpad implementations.

Figure 5: MPR083 Block Diagram

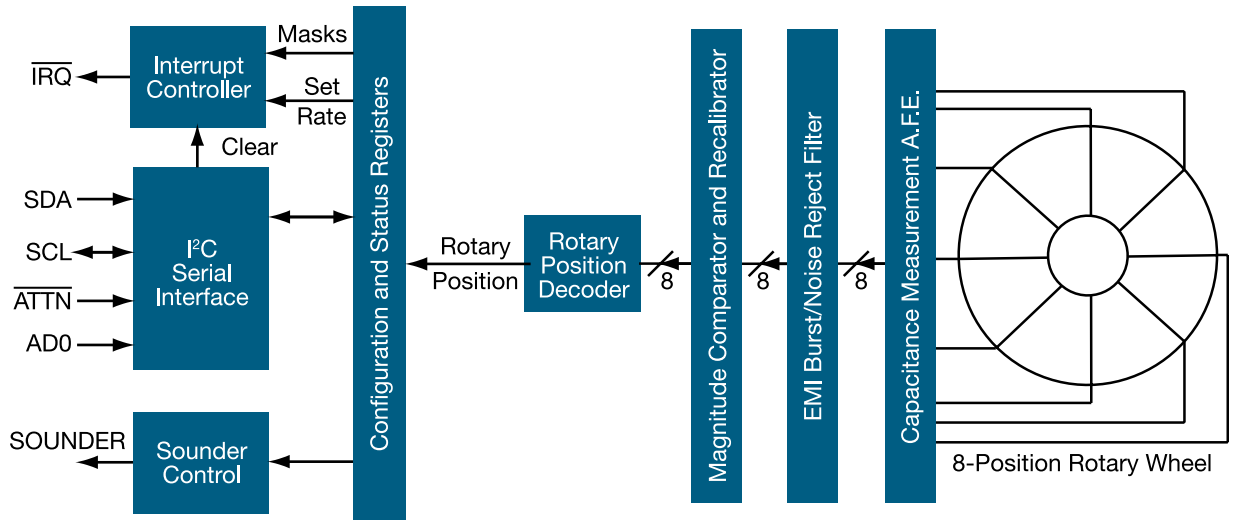

Additional Applications for Proximity Capacitive Sensors

Whereas touch sensing is a rapidly growing market for proximity capacitive sensors, they are also used in a number of other innovative applications in the consumer, industrial and automotive markets. For example:

Liquid level sensing—A simple design using proximity capacitive sensing for measuring liquid levels involves placing vertical electrode strips across a water column, thus forming a vertical capacitor between the walls of the water column. When the column is empty, a single capacitor is formed. But when water is introduced, the capacitor is split in two, with one being filled with air (dielectric of 1) and the other filled with water (dielectric of about 80). A simple algorithm can determine the liquid height. Unfortunately, in an application such as a washing machine, this system cannot compensate for different dielectric properties in the water as detergent is introduced and soil and other impurities begin to appear.

A more sophisticated capacitance system uses gradient electrodes, where electrode arrangement involves two plates of equally varying thicknesses overlapping each other. As the liquid rises, different areas of the electrodes will be in “contact” with the water and a unique ratio between them can be extracted. The ratio will be directly related to the liquid level while the absolute values of the area will provide dielectric information, which can be used to estimate soap and dirt content in the water.

Proximity sensing—Another common usage of proximity capacitive sensors relies on their ability to detect the proximity of an object. The capacitor model equation [Fig. 2] demonstrates that the capacitance is inversely proportional to the distance between the two capacitor plates ($1/d$). In a typical application, a conductive electrode pad will be one plate of the capacitor while the desired object will act as the other capacitor plate.

Since the relationship between the distance and the capacitance is asymptotic, this type of sensor is better suited in applications where high resolution in close proximity is desired. For example, Freescale’s MC34940 proximity capacitive touch sensor is able to detect a hand at 12 inches distance using a 1ft 2in pad as an electrode.

Proximity sensing technology can play an important part in security and safety applications in a number of markets. For instance, they can be used to detect the presence of seated occupants in a car and even determine the size of the occupants to trigger seat belt alarms and provide valuable data to the airbag deployment system.

Figure 6: Close Proximity Sensing

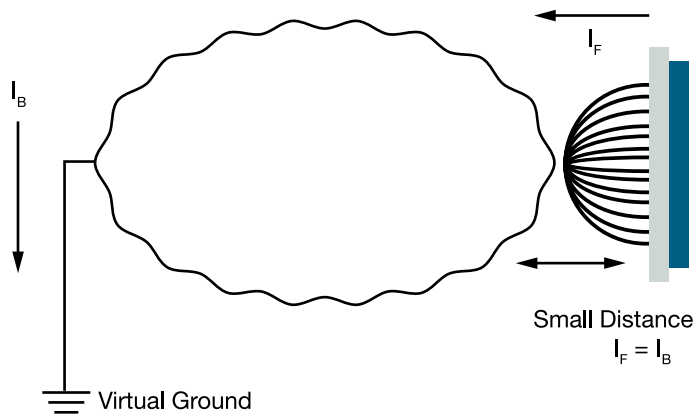

Multiple Electrodes and Shield Drive Technology

Freescale's MC33794, MC33941 and MC34940 proximity capacitive touch sensors can support multiple electrodes, providing a platform for several applications controlled by one chip, even if those applications are widely spaced. However, as the electrode signals are transmitted through wires or coax cables to the sensor IC, they can be weakened by external interference. To minimize this interference, Freescale has incorporated a shield driver in each of these parts.

The shield driver circuit provides a buffered version of the electrode's returned AC signal. Since it has nearly the same amplitude and phase as the electrode signal, there is little or no potential difference between the two signals, thereby canceling out any electric field. In effect, the shield drive isolates the electrode signal from external virtual grounds, resulting in remote electrode measurements as accurate as if they were in close proximity to the IC. [Fig. 7] A common application is to connect the shield driver to the shield of a coax cable used to connect an electrode to the corresponding electrode terminal.

Figure 7: Shield Drive Technology

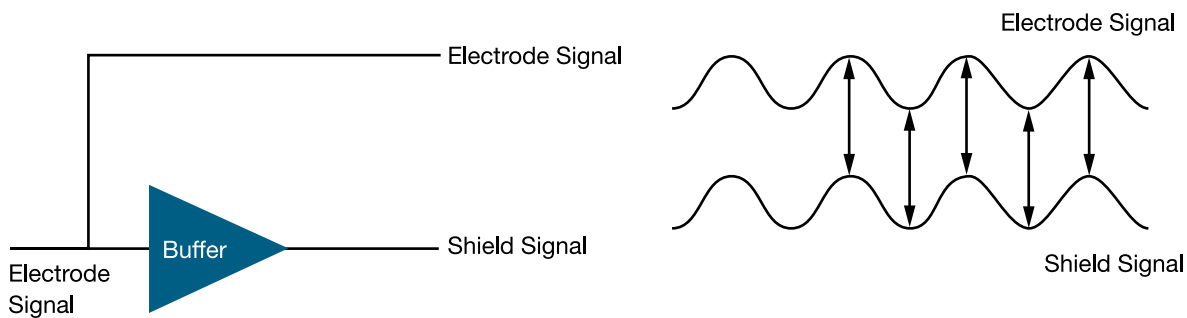

Another typical use for shield drive technology is to drive a ground plane used behind an array of touch sensor electrodes to cancel out any virtual grounds that could weaken the AC signal. [Fig. 8] The shield drive limits signal losses to the fringe field, thereby helping to ensure the strongest potential e-field, and, in a touch panel example, increasing the touch pad's sensitivity.

Figure 8: The Advantage of Shield Drive Technology

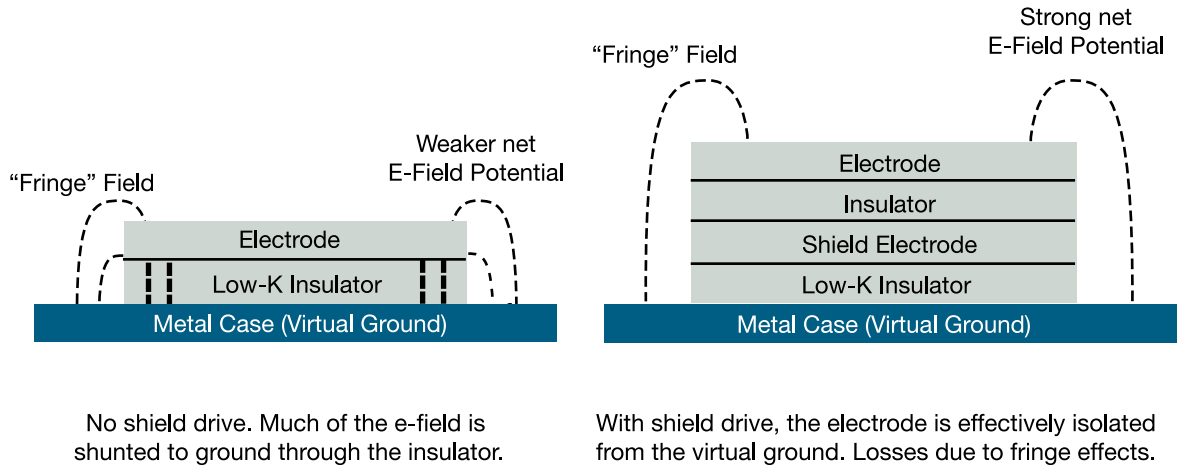

Shield drive technology allows developers to not only drive a number of separate applications using a minimal number of proximity capacitive touch sensors, but also to design large arrays of separate electrodes to perform identical functions over a wider area, such as smart floor mats that can sense occupants and even track their movements. Combine proximity sensing with a wireless protocol, such as ZigBee™ technology, for expanded control and tie-in to a local area network, and the application opportunities are practically endless. Safety, security, lighting, integrated entertainment controls and general proximity detection are just a few that can take advantage of the convenience and relatively inexpensive characteristics of proximity capacitive sensing technology.

Conclusion

Proximity capacitive sensors are rapidly proliferating across thousands of consumer, industrial and automotive applications. Designing control panel applications that use intelligent touch control interfaces offers a number of advantages to the manufacturer and consumer alike, including:

- Replacing mechanical buttons, switches and sliders
- Enhancing reliability by eliminating mechanical wear and tear
- Providing greater flexibility for product designers
- Reducing overall system costs
- Simplifying machine control interfaces

Freescale's proximity capacitive touch sensor portfolio will continue to expand to provide manufacturers with more opportunities to incorporate proximity capacitive sensors in their new product designs. Freescale's proximity capacitive touch sensing technology has brought new levels of accuracy, usability and reliability in control panel design, and it will continue to help customers create new applications in emerging markets worldwide.

How to Reach Us:

Home Page:

www.freescale.com

Web Support:

www.freescale.com/support

USA/Europe or Locations Not Listed:

Freescale Semiconductor, Inc.
Technical Information Center, EL516
2100 East Elliot Road
Tempe, Arizona 85284
+1-800-521-6274 or +1-480-768-2130
support@freescale.com

Europe, Middle East, and Africa:

Freescale Halbleiter Deutschland GmbH
Technical Information Center
Schatzbogen 7
81829 Muenchen, Germany
+44 1296 380 456 (English)
+46 8 52200080 (English)
+49 89 92103 559 (German)
+33 1 69 35 48 48 (French)
support@freescale.com

Japan:

Freescale Semiconductor Japan Ltd.
Headquarters
ARCO Tower 15F
1-8-1, Shimo-Meguro, Meguro-ku,
Tokyo 153-0064, Japan
0120 191014
+81 3 5437 9125
support.japan@freescale.com

Asia/Pacific:

Freescale Semiconductor Hong Kong Ltd
Technical Information Center
2 Dai King Street
Tai Po Industrial Estate,
Tai Po, N.T., Hong Kong
+800 2666 8080
support.asia@freescale.com

For Literature Requests Only:

Freescale Semiconductor
Literature Distribution Center
P.O. Box 5405
Denver, Colorado 80217
1-800-441-2447
303-675-2140
Fax: 303-675-2150
LDCForFreescaleSemiconductor@hibbertgroup.com

Information in this document is provided solely to enable system and software implementers to use Freescale Semiconductor products. There are no express or implied copyright license granted hereunder to design or fabricate any integrated circuits or integrated circuits based on the information in this document.

Freescale Semiconductor reserves the right to make changes without further notice to any products herein. Freescale Semiconductor makes no warranty, representation or guarantee regarding the suitability of its products for any particular purpose, nor does Freescale Semiconductor assume any liability arising out of the application or use of any product or circuit, and specifically disclaims any and all liability, including without limitation consequential or incidental damages. "Typical" parameters which may be provided in Freescale Semiconductor data sheets and/or specifications can and do vary in different applications and actual performance may vary over time. All operating parameters, including "Typicals" must be validated for each customer application by customer's technical experts. Freescale Semiconductor does not convey any license under its patent rights nor the rights of others. Freescale Semiconductor products are not designed, intended, or authorized for use as components in systems intended for surgical implant into the body, or other applications intended to support or sustain life, or for any other application in which the failure of the Freescale Semiconductor product could create a situation where personal injury or death may occur. Should Buyer purchase or use Freescale Semiconductor products for any such unintended or unauthorized application, Buyer shall indemnify and hold Freescale Semiconductor and its officers, employees, subsidiaries, affiliates, and distributors harmless against all claims, costs, damages, and expenses, and reasonable attorney fees arising out of, directly or indirectly, any claim of personal injury or death associated with such unintended or unauthorized use, even if such claim alleges that Freescale Semiconductor was negligent regarding the design or manufacture of the part.