



Analogue, Microcontrollers, Sensors

# Airbag Systems

## Automotive safety systems

### Overview

Automotive airbag systems continue to enhance passenger safety through the incorporation of increasingly sophisticated features. Automotive suppliers face continuing pressure from the market to improve performance while reducing costs. Both of these trends are expected to continue as the focus on safety remains in the forefront.

Freescale is a leading semiconductor supplier for next-generation airbag applications, with custom and standard microcontrollers (MCU), analogue and sensor products. We offer solutions for point-to-point and bus-based satellite interface architectures with the established distributed system interface (DSI) as well as the emerging peripheral sensor interface (PSI5) architectures. Our airbag system portfolio offers an array of technology solutions that help you with even your most challenging airbag system designs, while providing quality solutions from entry-level to high-end applications.

Within Freescale's broad portfolio, the Xtrinsic accelerometers in the low-, mid- and high-g range cover local and satellite sensor needs (XY-, X- and Z-axis). For system control, a range of 16- and 32-bit MCU solutions addresses low- to high-end system requirements, as well as 8- and 16-bit MCU solutions for the safing functions.

Freescale also provides SMARTMOS-based analogue and mixed signal standard product solutions for integrating power supply, satellite

interfaces, buckle switch sensors, squib drivers and controller area network (CAN) and local interconnect network (LIN) physical layers.

### Airbag System – PSI5 Protocol

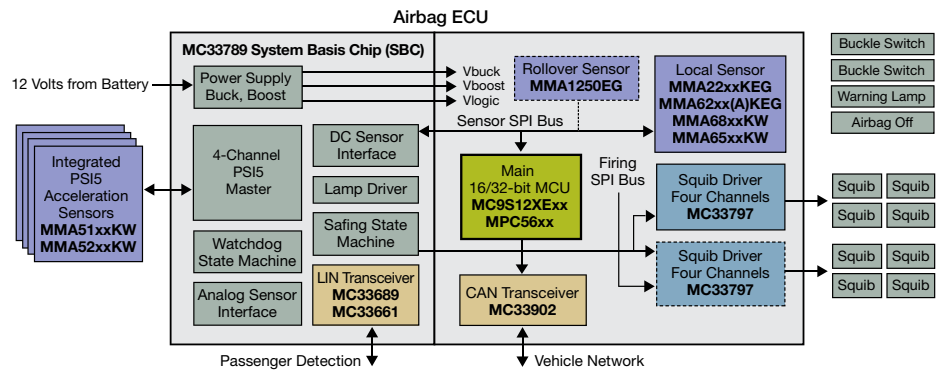

### Airbag System – DSI Protocol

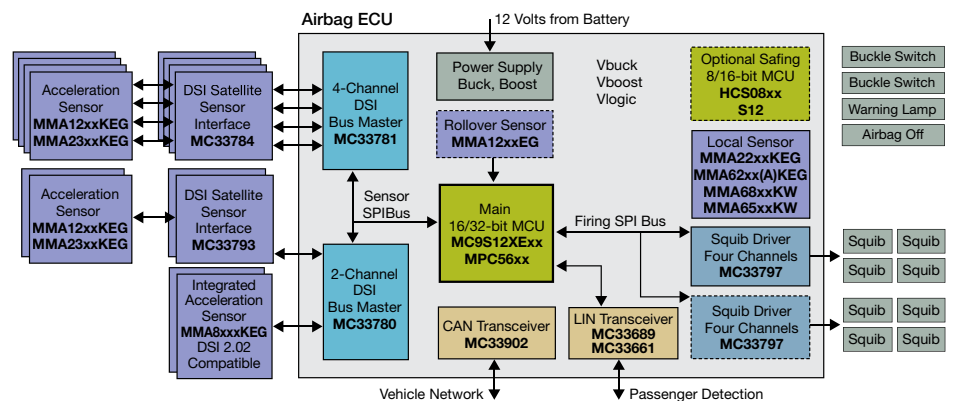

## Typical Applications

- Crash detection
- Front crash detection
- Side crash detection
- Rollover sensing

## Features and Benefits

- Freescale portfolio: Our airbag system solution strategy with MCUs, analog and Xtrinsic sensor products expands the functionality customers can combine for cost effectiveness with a next-generation performance progression path.
- Quality commitment: Our airbag system portfolio provides world-class quality solutions for entry-level to high-end applications through compliance with the ISO/TS 16949 quality standard as well as other critical automotive standards.
- Cost reduction: Customers can reduce system costs while enhancing passenger safety. For example, customers can place multiple satellite sensors on a single bus.
- Integration: Emerging safety systems will continue to be clustered into the airbag ECU and other areas, driving system complexity and increasing the need to optimize partitioning.
- Proven standards: Freescale and its customers work with car makers to utilize proven standards, such as DSI and the emerging PSI5 architectures.

## Freescale: A Leader in Automotive Semiconductors

Freescale is a leading supplier of automotive semiconductors, with more than 30 years of experience in the automotive industry. Freescale's sensors, analog products and 8-, 16- and 32-bit MCU families provide intelligence and connectivity for advanced safety, body electronics, chassis, engine control, powertrain, driver information and telematics. Freescale is a pioneer in FlexRay™ technology and was the first supplier to integrate CAN, LIN and flash memory technologies on automotive MCUs.

## Ordering Information

Product	Description	Main Characteristics
<b>Microcontrollers</b>		
MPC56xx	The 32-bit Power Architecture® based MPC56xxx family supports an array of package options for systems performance and embedded flash requirements	Program flash range of 256 to 512 KB with separate data flash and error correction code (ECC) make the MPC56xx suitable for safety applications. Variable length encoding (VLE) offers 32-bit performance with 16-bit code efficiency
MC9S12XE	The highly efficient 16-bit MC9S12XE family has high-end advanced features including 32-bit calculation capability	Program flash range of 128 KB to 1 MB with EEPROM with ECC and memory protection (MPU) make the MC9S12XE suitable for safety applications. XGATE coprocessor is capable of functioning separately as a watchdog processor
MC9S08SG	The cost-efficient 8-bit MC9S08SG family runs up to 40 MHz to provide 16-bit performance at 8-bit cost	Program flash range of 4 to 32 KB. No external crystal is required. Safety features include low voltage interrupt (LVI), watchdog and temperature sensors
<b>Sensors</b>		
MMA5xxxKW	PSI5-compatible X- or Z-axis satellite inertial sensors that contain the next-generation HARMEMS over-damped transducer	Available in +/-60g, +/-120g, +/-240g, +/-480g versions
MMA65xxKW	SPI-compatible serial interface main ECU 12-bit digital inertial sensors with independent programmable arming functions for each axis	MMA65xxKW X-axis devices at +/-105g or +/-120g full-scale range on each axis MMA65xxKW XY-axis devices at +/-80g, +/-105g or +/-120g full-scale range on each axis
MMA68xxKW	SPI-compatible serial interface main ECU 10-bit digital inertial sensors with independent programmable arming functions for each axis	Available in ranges from +/-20g to +/-120g
MMA8xxxKEG	DSI 2.02 compatible X- or Z-axis satellite inertial sensors	Available in +/-20g, +/-40g, +/-50g, +/-100g, +/-150g, +/-200g, +/-250g versions
MMA62xx(A)KEG	The MMA62xxEG series of XY-axis accelerometers features digital signal processing for filtering, trim and data formatting. These products contain the next-generation HARMEMS over-damped transducer	Available in +/-20g, +/-50g, or +/-100g versions. The parts have 10-bit digital data output. These accelerometers are SPI-compatible
MMA22xxKEG	The MMA22xxEG series includes X-axis accelerometers	Available in +/-1.5g, +/-40g, +/-50g, or +/-100g versions
MMA32xxKEG	The MMA32xxEG series includes XY-axis accelerometers	Available in +/-40/40g, +/-100/30g, +/-100/50g versions
<b>CAN and LIN Transceivers and Squib Driver Analog Components</b>		
MC33661	LIN enhanced physical interface	Local interconnect network (LIN) is a serial communication protocol designed to support automotive networks
MC33689	System base chip (SBC) with LIN physical interface	An SPI controlled SBC combining many functions with a LIN transceiver for slave node applications
MC33902	High-speed CAN physical interface with embedded 5-volt supply	A high-speed CAN physical interface. The device includes an internal 5-volt supply for the CAN bus transceiver, and requires only a connection to a battery line
MC33797	Four-channel squib driver IC	Four-channel high-side and low-side 2.0 A FET switches, cross-coupled driver capability, externally adjustable FET current limit, SPI port for MCU interface, diagnostics for high-side safing sensor status
<b>Peripheral Sensor Interface 5 (PSI5) and Distributed Systems Interface (DSI)</b>		
MC33789	PSI5 Airbag SBC	Airbag control module monitors battery voltage, satellite sensor status and supplies various voltages to the airbag system using SPI for communication
MC33780	Dual DSI 2.02 master with differential drive	Bus controller for two differential DSI channels. SPI port for MCU interface. Variable CRC generation and detection, thermal protection, frequency spreading
MC33781	Quad DSI 2.02 master with differential drive	Bus controller for four differential DSI channels. Dual SPI ports for MCU and safing interfaces. Variable CRC generation and detection, comprehensive fault detection, thermal protection, frequency spreading
MC33784	DSI 2.02 sensor interface	DSI slave device optimized as a sensor interface. Differential bus capability and dual bus switches for improved EMC performance, 2-channel 10-bit ADC, 5-volt regulated output, three configurable logic pins, CRC generation and checking
MC33793	DSI 2.02 sensor interface	DSI slave device. 5-volt regulated output, four configurable I/O pins (logic I/O or 8-bit ADC), fault tolerant, logic output high current buffer

For more information, visit [freescale.com/automotive](http://freescale.com/automotive)

Contact your Freescale Semiconductor sales representative about the complete product portfolio.

Freescale and the Freescale logo are trademarks of Freescale Semiconductor, Inc., Reg. U.S. Pat. & Tm. Off. The Power Architecture and Power.org word marks and the Power and Power.org logos and related marks are trademarks and service marks licensed by Power.org. All other product or service names are the property of their respective owners. © 2011 Freescale Semiconductor, Inc.

Document Number: AIRBAGFS REV 6

