

RF Tape and Reel Specifications

Embossed Tape and Reel is used to facilitate automatic pick and place equipment feed requirements. The tape is used as the shipping container for various products and requires a minimum of handling. The antistatic/conductive tape provides a secure cavity for the product when sealed with the “peel-back” cover tape.

- Two Reel Sizes Available (7” and 13”)
- Used for Automatic Pick and Place Feed Systems
- Minimizes Product Handling
- EIA 481, -1, -2
- SOT-363 in 8 mm Tape
- PLD-1.5, QFN 3x3, QFN 4x4, SOT-89 in 12 mm Tape
- PFP-16, PQFN 5x5 in 16 mm Tape
- TO-270-2, TO-270-2 Gull in 24 mm Tape
- NI-360, NI-360HF, NI-360S, NI-400, NI-400S in 32 mm Tape
- TO-270 WB-4, TO-270 WBL-4, TO-270 WB-14, TO-270 WB-14 Gull, TO-270 WB-16, TO-270 WB-16 Gull, TO-272-2, TO-272-6, TO-272-6 Wrap, TO-272-8, TO-272-8 Wrap, TO-272 WB-4, TO-272 WB-14, TO-272 WB-16, TO-272 WB-16 Gull, in 44 mm Tape
- NI-780, NI-780S, NI-860, NI-880, NI-880S, NI-1230, NI-1230S in 56 mm Tape

Use the standard device title and add the required suffix as listed in the option table on the following page. Note that the individual reels have a finite number of devices depending on the type of product contained in the tape. Also note the minimum lot size is one full reel for each line item, and orders are required to be in increments of the single reel quantity.

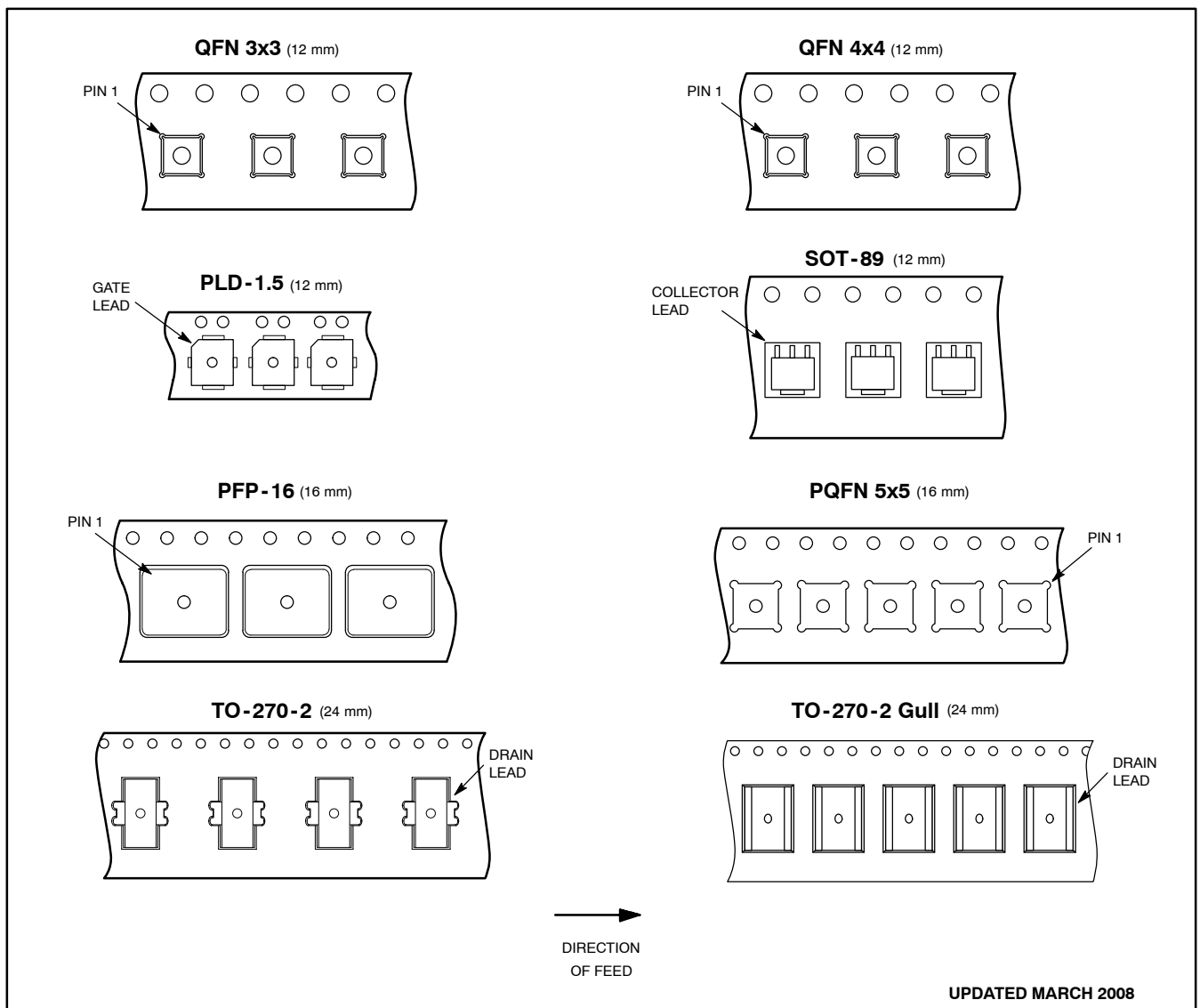

NI-360, NI-360HF, NI-360S (32 mm)

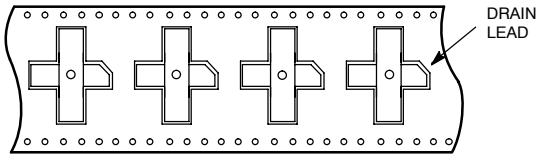

NI-400, NI-400S (32 mm)

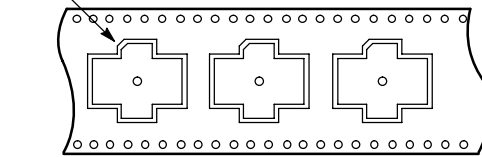

TO-272-2, TO-272-6 Wrap, TO-272-6, TO-272-8, TO-272-8 Wrap (44 mm)

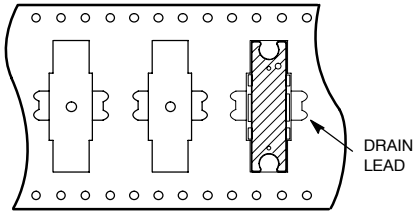

TO-270 WB-4, TO-270 WBL-4, TO-270 WB-14, TO-270 WB-16, TO-272 WB-4, TO-272 WB-14, TO-272 WB-16 (44 mm)

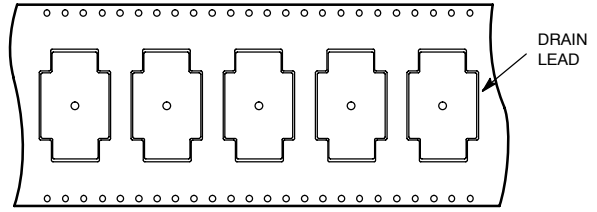

TO-270 WB-14 Gull, TO-270 WB-16 Gull, TO-272 WB-16 Gull (44 mm)

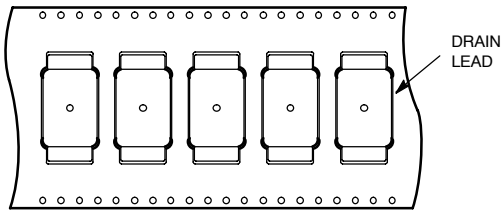

NI-780, NI-780S (56 mm)

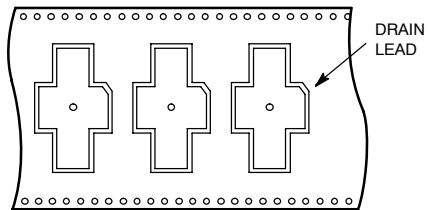

NI-860 (56 mm)

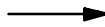
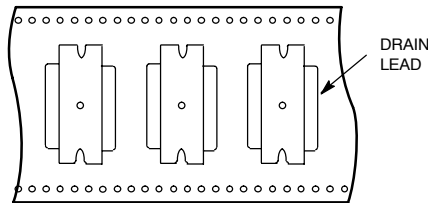

DIRECTION OF FEED

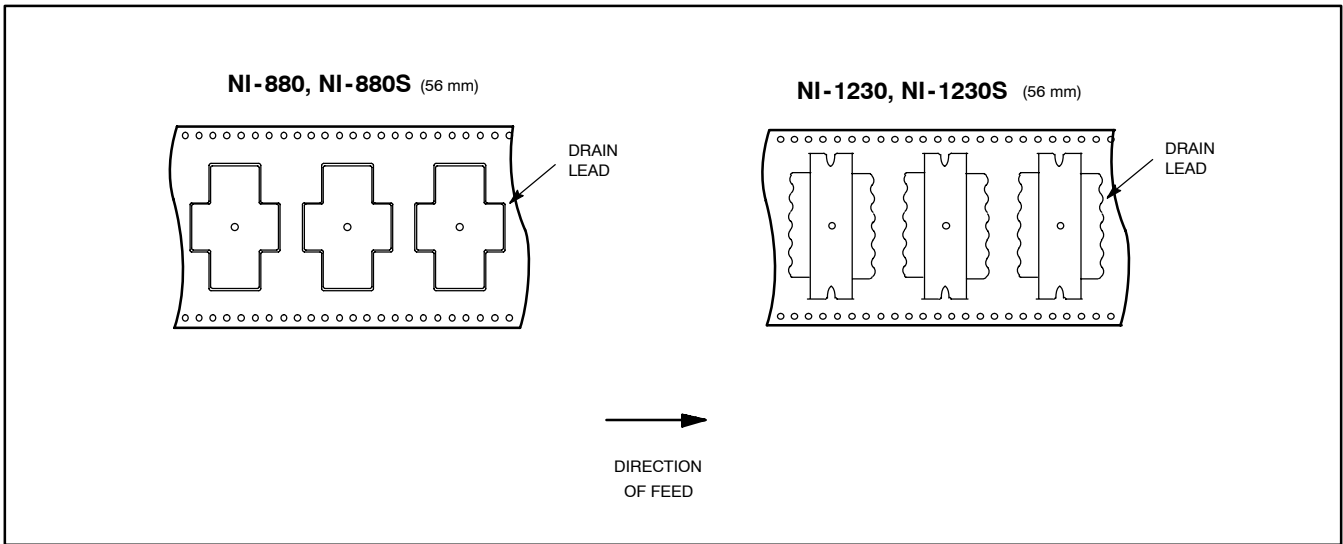

RF EMBOSSED TAPE AND REEL ORDERING INFORMATION

Package	Tape Width (mm)	Pitch (mm (inch))	Reel Size (mm (inch))	Devices Per Reel and Minimum Order Quantity	Device Suffix
NI-360 (360B)	32	24.0 ± 0.1 (.945 ± .004)	330 (13)	500	R1
NI-360HF (360D)	32	24.0 ± 0.1 (.945 ± .004)	330 (13)	500 50	R1 R5
NI-360S (360C)	32	24.0 ± 0.1 (.945 ± .004)	330 (13)	500	R1
NI-400 (465E)	32	32.0 ± 0.1 (1.26 ± .004)	330 (13)	250	R3
NI-400S (465F)	32	32.0 ± 0.1 (1.26 ± .004)	330 (13)	250	R3
NI-780 (465)	56	32.0 ± 0.1 (1.26 ± .004)	330 (13)	250	R3
NI-780S (465A)	56	32.0 ± 0.1 (1.26 ± .004)	330 (13)	250	R3
NI-860 (375B, 375G) (375G)	56 56	28.0 ± 0.1 (1.10 ± .004) 28.0 ± 0.1 (1.10 ± .004)	330 (13) 330 (13)	250 50	R3 R5
NI-880 (465B)	56	32.0 ± 0.1 (1.26 ± .004)	330 (13)	250	R3
NI-880S (465C)	56	32.0 ± 0.1 (1.26 ± .004)	330 (13)	250	R3
NI-1230 (375D)	56	32.0 ± 0.1 (1.26 ± .004)	330 (13)	150	R6
NI-1230S (375E)	56	32.0 ± 0.1 (1.26 ± .004)	330 (13)	150	R6
PPF-16 (978)	16	12.0 ± 0.1 (.472 ± .004)	330 (13)	1,500	R2
PLD-1.5 (466)	12 12	8.0 ± 0.1 (.315 ± .004) 8.0 ± 0.1 (.315 ± .004)	178 (7) 178 (7)	1,000 100	T1 R4
PQFN 5x5 (1543)	16	8.0 ± 0.1 (.315 ± .004)	330 (13)	1,000	T1
QFN 3x3 (1483)	12	8.0 ± 0.1 (.315 ± .004)	178 (7)	1,500	R2
QFN 4x4 (1898)	12	8.0 ± 0.1 (.315 ± .004)	330 (13)	1,000	T1
SOT-89 (1514)	12	8.0 ± 0.1 (.315 ± .004)	178 (7)	1,000	T1
SOT-363	8	4.0 ± 0.1 (.157 ± .004)	178 (7)	3,000	T1
TO-270-2 (1265)	24	16.0 ± 0.1 (.631 ± .004)	330 (13)	500	R1
TO-270-2 Gull (1265A)	24	12.0 ± 0.1 (.471 ± .004)	330 (13)	500	R1
TO-270 WB-4 (1486)	44	20.0 ± 0.1 (.788 ± .004)	330 (13)	500	R1
TO-270 WBL-4 (1730)	44	20.0 ± 0.1 (.788 ± .004)	330 (13)	500	R1
TO-270 WB-14 (1618)	44	20.0 ± 0.1 (.788 ± .004)	330 (13)	500	R1
TO-270 WB-14 Gull (1621)	44	16.0 ± 0.1 (.631 ± .004)	330 (13)	500	R1
TO-270 WB-16 (1886)	44	20.0 ± 0.1 (.788 ± .004)	330 (13)	500	R1
TO-270 WB-16 Gull (1887)	44	16.0 ± 0.1 (.631 ± .004)	330 (13)	500	R1
TO-272-2 (1337)	44	16.0 ± 0.1 (.631 ± .004)	330 (13)	500	R1
TO-272-6 (1264A)	44	16.0 ± 0.1 (.631 ± .004)	330 (13)	500	T1
TO-272-6 Wrap (1264)	44	16.0 ± 0.1 (.631 ± .004)	330 (13)	500	T1
TO-272-8 (1366A)	44	20.0 ± 0.1 (.787 ± .004)	330 (13)	500	T1
TO-272-8 Wrap (1366)	44	20.0 ± 0.1 (.787 ± .004)	330 (13)	500	T1
TO-272 WB-4 (1484)	44	20.0 ± 0.1 (.788 ± .004)	330 (13)	500	R1
TO-272 WB-14 (1617)	44	20.0 ± 0.1 (.788 ± .004)	330 (13)	500	R1
TO-272 WB-16 (1329)	44	20.0 ± 0.1 (.788 ± .004)	330 (13)	500	R1
TO-272 WB-16 Gull (1329A)	44	16.0 ± 0.1 (.631 ± .004)	330 (13)	500	R1

EMBOSSED TAPE AND REEL DATA FOR DISCRETES

CARRIER TAPE SPECIFICATIONS

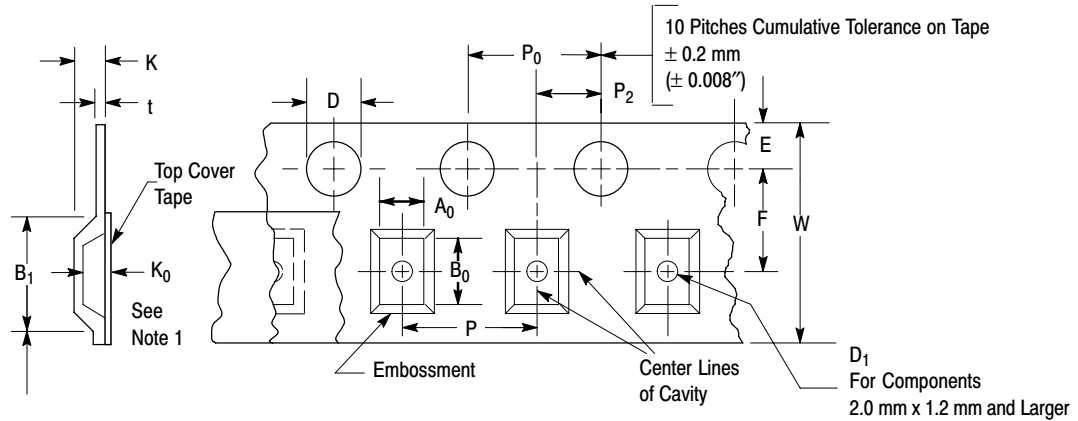

For Machine Reference Only
 Including Draft and RADII
 Concentric Around B_0

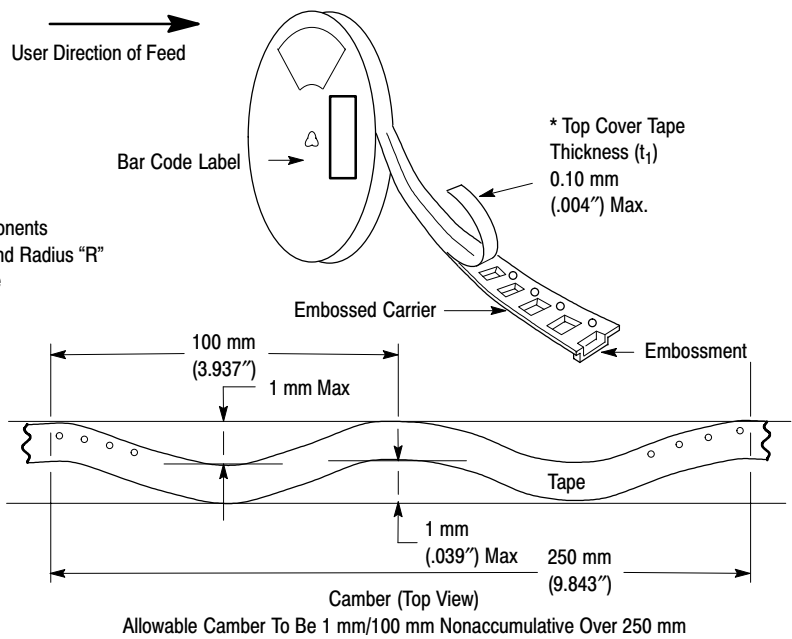
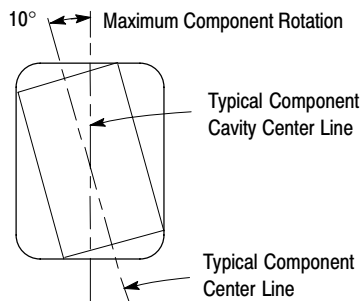
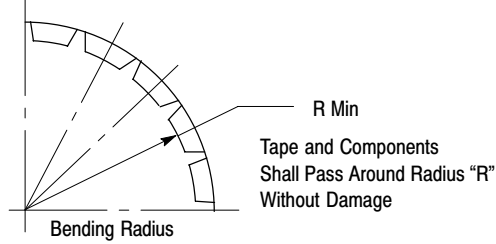

DIMENSIONS

Tape Size	B ₁ Max	D	D ₁	E ₁	F	K	P ₀	P ₂	R Min	t Max	W Max					
12 mm	8.2 mm (.323")	1.5±0.1 mm -0.0 (.059±.004" -0.0)	1.5 mm Min (.060")	1.75±0.1 mm (.069±.004")	5.5±0.05 mm (.217±.002")	6.4 mm Max (.252")	4.0±0.1 mm (.157±.004")	2.0±0.1 mm (.079±.004")	30 mm (1.18")	0.4 mm (.016")	12±.30 mm (.470±.012")					
	4.0 mm (.157") QFN 3x3											1.2 mm Max (.048") QFN 3x3 QFN 4x4	2.0±0.5 mm (.079±.002")	0.30 mm (.012")		
	4.45 mm (.175") QFN 4x4		1.7 mm Min (.068") SOT-89			1.9 mm Max (.076") SOT-89		2.0±0.1 mm (.079±.004")		0.4 mm (.016")		12±.2 mm (.470±.008") SOT-89				
	5.1 mm (.201") SOT-89					7.9 mm Max (.311")							2.0±0.1 mm (.079±.004")	0.4 mm (.016")	16±.3 mm (.642±.008")	
16 mm	12.1 mm (.476")	1.5 mm Min (.060")	1.5 mm Min (.060")	7.5±0.10 mm (.295±.004")	7.9 mm Max (.311")	2.8 mm Max (.110") PQFN 5x5	4.0±0.2 mm (.157±.001") PQFN 5x5	2.0±0.5 mm (.079±.002") PQFN 5x5	0.4 mm (.016")	0.30 mm (.012") PQFN 5x5	16±.3 mm (.642±.008")					
	6.1 mm (.241") PQFN 5x5											11.5±0.1 mm (.453±.004")	11.9 mm Max (.468")	4.0±0.1 mm (.157±.004")	2.0±0.1 mm (.079±.004")	0.4 mm (.016")
24 mm	20.1 mm (.791")	1.5 mm Min (.059")	1.5 mm Min (.059")	14.2±0.1 mm (.559±.004")	4.6 mm (.181") NI-360/HF/S	2.82 mm Max (.111") TO-270-2 Gull	4.0±0.1 mm (.157±.004")	2.0±0.1 mm (.079±.004")	50 mm (1.969")	0.6 mm (.024")	32.2 mm (1.272")					
	11.1 mm (.437") TO-270-2 Gull											4.3 mm (.169") NI-400/S	5.34 mm (.210") NI-600/S	0.338 mm (.013") TO-270-2 Gull		
32 mm	23.0 mm (.906")	1.5 mm Min (.059")	1.5 mm Min (.059")	14.2±0.1 mm (.559±.004")	4.6 mm (.181") NI-360/HF/S	2.82 mm Max (.111") TO-270-2 Gull	4.0±0.1 mm (.157±.004")	2.0±0.1 mm (.079±.004")	50 mm (1.969")	0.6 mm (.024")	32.2 mm (1.272")					
												4.3 mm (.169") NI-400/S	5.34 mm (.210") NI-600/S	0.338 mm (.013") TO-270-2 Gull		
															4.3 mm (.169") NI-400/S	5.34 mm (.210") NI-600/S
44 mm	35.0 mm (1.378")	2.0 mm Min (.079")	2.0 mm Min (.079")	11.5±0.1 mm (.453±.004")	15.9 mm Max (.625")	15.9 mm Max (.625")	20.0±0.1 mm (.788±.004") TO-272 WB-4, TO-272 WB-16	2.0±0.15 mm (.079±.006")	50 mm (1.969")	0.6 mm (.024")	44±.30 mm (1.732±.012")					
												20.2±0.15 mm (0.796±.006")	2.92 mm (.115") TO-272 WB-4, TO-272 WB-16	2.92 mm (.115") TO-272 WB-4, TO-272 WB-16	2.0±0.15 mm (.079±.006")	.318 mm (.012") TO-272 WB-4, TO-272 WB-16
23.77 mm (.936") TO-270 WB-14 Gull, TO-270 WB-16 Gull, TO-272 WB-16 Gull	3.20 mm (.126") TO-272 WB-16 Gull	16.0±0.1 mm (.630±.004") WB-16 Gull	2.0±0.15 mm (.079±.006")	.343 mm (.013") TO-272 WB-16 Gull												

Metric dimensions govern — English are in parentheses for reference only.

NOTE 1: A₀, B₀, and K₀ are determined by component size. The clearance between the components and the cavity must be within .05 mm min. to .50 mm max., the component cannot rotate more than 10° within the determined cavity.

NOTE 2: Pitch information is contained in the Embossed Tape and Reel Ordering Information on pg. 4.

Tape and Reel Specifications

DIMENSIONS (continued)

Tape Size	B ₁ Max	D	D ₁	E ₁	F	K	P ₀	P ₂	R Min	t Max	W Max	
56 mm	34.7 mm (1.366") NI-780/S NI-860 NI-880/S	1.5+0.1 mm -0.0 (.059+.004" -0.0)	2.0 mm Min (.079")	1.75±0.1 mm (.069±.004")	26.2 ±0.15 mm (1.031±.006")	4.5 mm (0.177") NI-780/S	4.0±0.1 mm (.157±.004")	2.0±0.15 mm (.079±.006")			0.6 mm (.024") NI-780/S NI-860 NI-880/S NI-1230	56±.30 mm (2.205± .012")
	5.0 mm (0.197") NI-860											
	5.23 mm (0.206") NI-880/S											
	5.2 mm (0.205") NI-1230											
	41.6 mm (1.638") NI-1230											

Metric dimensions govern — English are in parentheses for reference only.

NOTE 1: A₀, B₀, and K₀ are determined by component size. The clearance between the components and the cavity must be within .05 mm min. to .50 mm max., the component cannot rotate more than 10° within the determined cavity.

NOTE 2: Pitch information is contained in the Embossed Tape and Reel Ordering Information on pg. 4.

EMBOSSED TAPE AND REEL DATA FOR DISCRETES

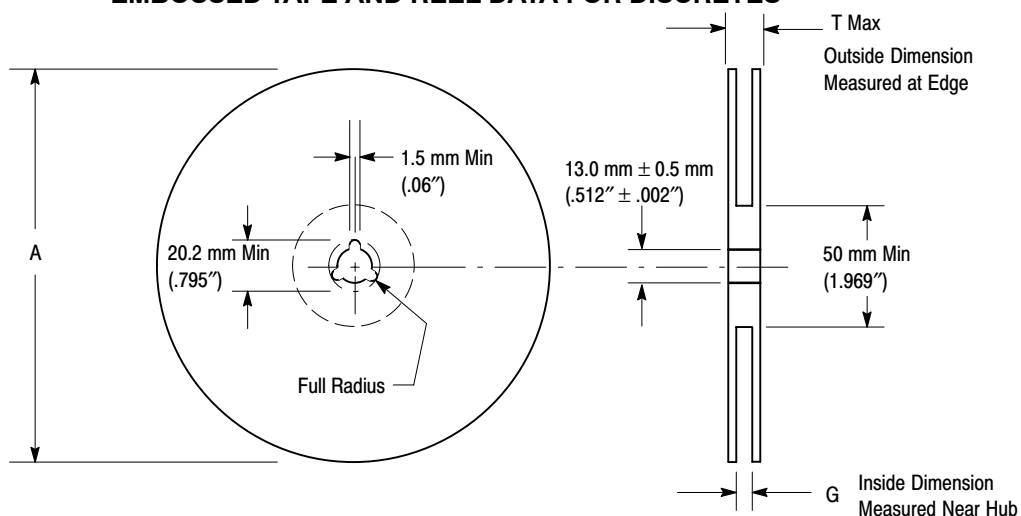

Size	A Max	G	T Max
12 mm	330 mm (12.992")	12.4 mm + 2.0 mm, - 0.0 (.49" + .079", - 0.00)	18.4 mm (.72")
12 mm QFN 3x3 QFN 4x4	178 mm (7")	12.4 mm + 2.0 mm, - 0.0 (.49" + .079", - 0.00)	18.4 mm (.72")
12 mm SOT-89	178 mm (7")	13.5 mm (.53")	16.5 mm (.65")
16 mm	330 mm (14.173")	16.4 mm + 2.0 mm, - 0.0 (.646" + .078", - 0.00)	22.4 mm (.882")
16 mm PQFN 5x5	360 mm (14.173")	16.4 mm + 2.0 mm, - 0.0 (.646" + .078", - 0.00)	22.4 mm (.882")
24 mm	360 mm (14.173")	24.4 mm + 2.0 mm, - 0.0 (.961" + .070", - 0.00)	30.4 mm (1.197")
24 mm TO-270-2 Gull	330 mm (12.992")	24.4 mm + 2.0 mm, - 0.0 (.961" + .070", - 0.00)	30.4 mm (1.197")
32 mm	360 mm (14.163")	32.4 mm + 2.0 mm, - 0.0 (1.276" + 0.79", - 0.00)	38.4 mm (1.512")
44 mm	330 mm (12.992")	44.4 mm + 2.0 mm, - 0.0 (1.748" + 0.79", - 0.00)	50.4 mm (1.984")
44 mm TO-270 WB-4, WBL-4, WB-14, WB-14 Gull, WB-16, WB-16 Gull, TO-272 WB-4, WB-14, WB-16, WB-16 Gull	330 mm (12.992")	45.3 mm + 0.5 mm, - 0.0 (1.785" + 0.02", - 0.00)	50.4 mm (1.984")
56 mm	330 mm (12.992")	56.4 mm + 2.0 mm, - 0.0 (2.220" + 0.79", - 0.00)	62 mm (2.441")

Reel Dimensions

Metric Dimensions Govern — English are in parentheses for reference only

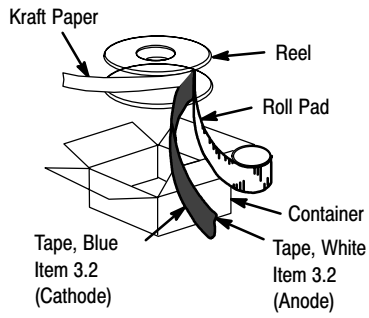

Figure 1. Reel Packing

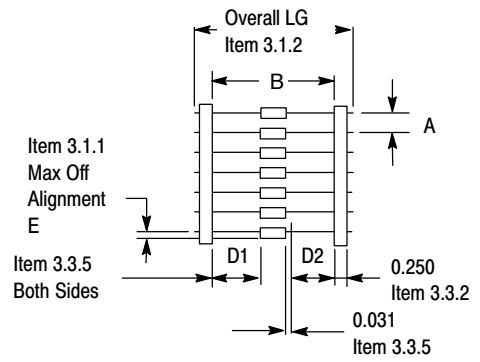

Figure 2. Component Spacing

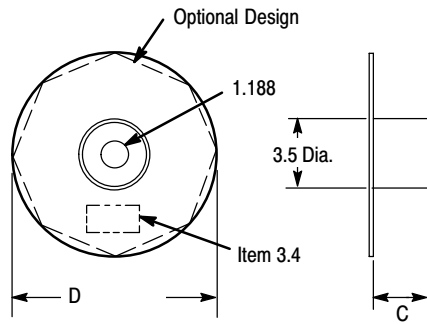

Figure 3. Reel Dimensions

How to Reach Us:

Home Page:

www.freescale.com

Web Support:

<http://www.freescale.com/support>

USA/Europe or Locations Not Listed:

Freescale Semiconductor, Inc.
Technical Information Center, EL516
2100 East Elliot Road
Tempe, Arizona 85284
+1-800-521-6274 or +1-480-768-2130
www.freescale.com/support

Europe, Middle East, and Africa:

Freescale Halbleiter Deutschland GmbH
Technical Information Center
Schatzbogen 7
81829 Muenchen, Germany
+44 1296 380 456 (English)
+46 8 52200080 (English)
+49 89 92103 559 (German)
+33 1 69 35 48 48 (French)
www.freescale.com/support

Japan:

Freescale Semiconductor Japan Ltd.
Headquarters
ARCO Tower 15F
1-8-1, Shimo-Meguro, Meguro-ku,
Tokyo 153-0064
Japan
0120 191014 or +81 3 5437 9125
support.japan@freescale.com

Asia/Pacific:

Freescale Semiconductor Hong Kong Ltd.
Technical Information Center
2 Dai King Street
Tai Po Industrial Estate
Tai Po, N.T., Hong Kong
+800 2666 8080
support.asia@freescale.com

For Literature Requests Only:

Freescale Semiconductor Literature Distribution Center
P.O. Box 5405
Denver, Colorado 80217
1-800-441-2447 or 303-675-2140
Fax: 303-675-2150
LDCForFreescaleSemiconductor@hibbertgroup.com

Information in this document is provided solely to enable system and software implementers to use Freescale Semiconductor products. There are no express or implied copyright licenses granted hereunder to design or fabricate any integrated circuits or integrated circuits based on the information in this document.

Freescale Semiconductor reserves the right to make changes without further notice to any products herein. Freescale Semiconductor makes no warranty, representation or guarantee regarding the suitability of its products for any particular purpose, nor does Freescale Semiconductor assume any liability arising out of the application or use of any product or circuit, and specifically disclaims any and all liability, including without limitation consequential or incidental damages. "Typical" parameters that may be provided in Freescale Semiconductor data sheets and/or specifications can and do vary in different applications and actual performance may vary over time. All operating parameters, including "Typicals", must be validated for each customer application by customer's technical experts. Freescale Semiconductor does not convey any license under its patent rights nor the rights of others. Freescale Semiconductor products are not designed, intended, or authorized for use as components in systems intended for surgical implant into the body, or other applications intended to support or sustain life, or for any other application in which the failure of the Freescale Semiconductor product could create a situation where personal injury or death may occur. Should Buyer purchase or use Freescale Semiconductor products for any such unintended or unauthorized application, Buyer shall indemnify and hold Freescale Semiconductor and its officers, employees, subsidiaries, affiliates, and distributors harmless against all claims, costs, damages, and expenses, and reasonable attorney fees arising out of, directly or indirectly, any claim of personal injury or death associated with such unintended or unauthorized use, even if such claim alleges that Freescale Semiconductor was negligent regarding the design or manufacture of the part.

Freescale™ and the Freescale logo are trademarks of Freescale Semiconductor, Inc. All other product or service names are the property of their respective owners.

© Freescale Semiconductor, Inc. 2008. All rights reserved.

