

The XGATE Coprocessor

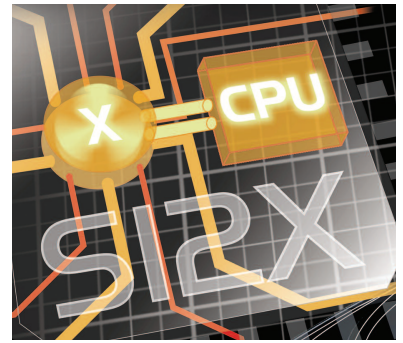

Key Benefits

- > Offloads CPU
- > Boosts performance
- > Create virtual peripherals
- > Partition software functionality

Use Cases

- > Networking (CAN and LIN gateways)
- > DMA
- > Sound generation
- > Quadrature decoder
- > Manchester encoder/decoder
- > Analog signal monitoring

Target Applications

- > Automotive body electronics applications
- > Central body computer
- > Passenger safety solutions
- > Dashboard cluster
- > Security
- > Climate control
- > HVAC actuators and sensors
- > Control panels
- > Industrial networked systems (standard and proprietary)
- > Motor control systems
- > Programmable logic controllers
- > Health care monitoring systems
- > TPMS and RKE receivers

Overview

The XGATE module on the advanced HCS12X family of 16-bit microcontrollers (MCUs) is a highly flexible, high-performance and cost-sensitive parallel processing solution.

The XGATE module is a peripheral coprocessor that allows autonomous high-speed data processing and transfers between the MCU's peripherals and the internal RAM and I/O ports. It has a built-in RISC core that is able to preprocess the transferred data and perform complex communication protocols.

The XGATE module is intended to increase the MCU's data throughput by lowering the S12X CPU's interrupt load. Running at up to 80 MHz in parallel to the S12X CPU, the XGATE is easily programmable in C.

MC9S12X FAMILY PRODUCT EXAMPLE

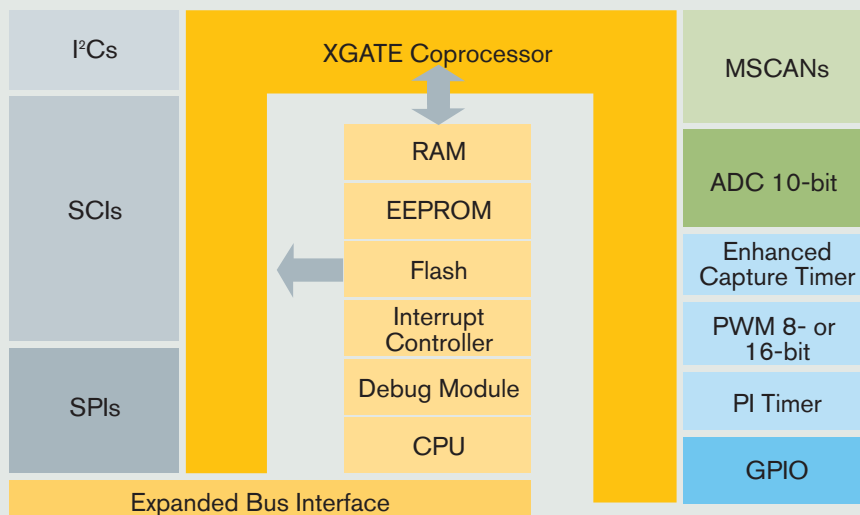

Features

- > Optimized 16-bit RISC core for data manipulation
- > Hardware semaphores for secure data sharing between cores
- > Interrupt-driven operations
- > Provides up to 112 XGATE channels
- > 104 hardware-triggered channels
- > Eight software-triggered channels
- > Able to trigger S12X_CPU interrupts upon completion of an XGATE transfer
- > Barrel shifter for fast data manipulation
- > Smart memory access protection avoiding conflicting CPU12 and XGATE accesses

Benefits

- > Advanced, easy-to-use interrupt processing peripheral
- > Programmable "Smart" DMA
- > Provides cost-effective CPU boost of up to 80 MHz parallel processing
- > Transfers data between all peripherals and RAM
- > Can also access 30K of Flash (read only)
- > Provides very flexible full CAN mailbox and filtering management when used with MSCAN
- > Enables efficient multi-LIN master capability
- > Easily programmable in standard C, compiler and debugger are integrated into the S12X tool suite
- > Single background debug mode (BDM) for debugging both S12X CPU and XGATE simultaneously while running at full speed



XGATE MODULE DELIVERS FULL CAN CAPABILITY—AND MORE

- > XGATE transfers CAN messages to/from appropriate mailboxes independently of CPU
- > XGATE can manipulate messages if required e.g. extract individual signals from within CAN message
- > Number of mailboxes set by user (limited only by size of RAM)

New feature on S12X allows "XGATE RAM" and "CPURAM" to be defined and protected from unauthorized overwrite.

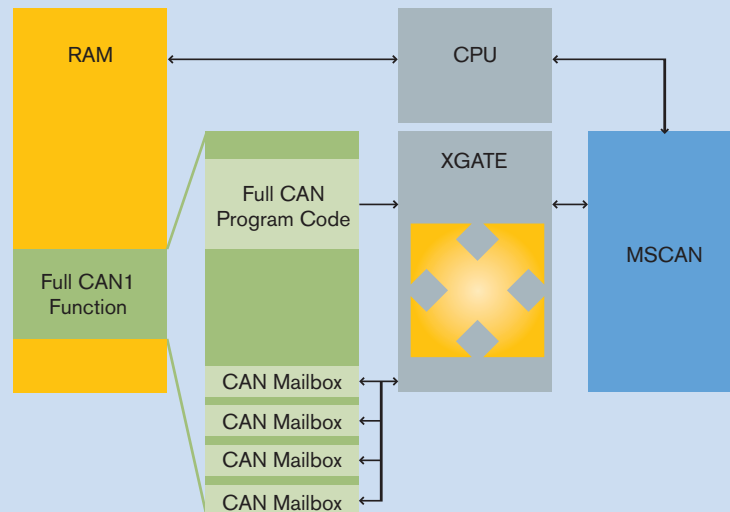

Other application ideas for XGATE:

- > CAN gateways/LIN multi-master
- > Software PWM
- > Quadrature encoders for motor control
- > Time triggered activities
- > Bit banging I/O (e.g. LCD, LED matrices)
- > Manchester decoder (e.g. on data from RKE/TPMS)
- > Enhanced watchdog capabilities (with internal timer)
- > Queued SPI/queued SCI

Learn More: For more information about Freescale's HCS12X Family, please visit www.freescale.com/S12X.

Freescale™ and the Freescale logo are trademarks of Freescale Semiconductor, Inc. All other product or service names are the property of their respective owners.

This product incorporates SuperFlash® technology licensed from SST.

© Freescale Semiconductor, Inc. 2004

XGATECOPROCFS

REV 0

Launched by Motorola
freescale
semiconductor