

Oziel Hernandez, Varun Jain, Suhas Chakravarty and Prashant Bhargava

# Position Location Monitoring

## Using IEEE<sup>®</sup> 802.15.4/ZigBee<sup>®</sup> technology

### Freescale and ZigBee<sup>®</sup> technology can help you locate your kids

In this article you will learn how Freescale and ZigBee technology can help you implement a low-cost, low-power location monitoring system for indoor environments where other positioning systems have typically performed poorly. This article is a useful tool to help system designers understand the very basic concepts of cooperative localization.

### Location monitoring without GPS? How does it work?

Believe it or not, it is possible to locate people or other objects in an indoor environment without using expensive global positioning system (GPS) devices. What's more, GPS performance inside buildings is very limited due to impaired line of sight (LOS) to the GPS satellites.

A location monitoring system can be developed with moderate performance with a ZigBee mesh network that uses low-cost IEEE 802.15.4 embedded devices. At this point, however, it is important to clarify what ZigBee technology and IEEE 802.15.4 are because sometimes they are erroneously used interchangeably.

IEEE 802.15.4 is a wireless standard that defines the physical (PHY) and medium access control (MAC) layers while ZigBee technology adds network (NWK) and application (APL) layer specifications on top of 802.15.4 to complete what is called the full ZigBee stack. For the scope of this article we are proposing ZigBee-compliant devices because the mesh networking capability is implemented in the NWK layer.

In Figure 1, we have a ZigBee mesh network where each device can communicate directly or through neighbor devices with other devices in the network. Connections between nodes are dynamically updated and optimized in difficult conditions. Mesh networks are decentralized where each node is self-routing and able to connect to other nodes as needed. The characteristics of mesh topology, thanks to the Ad hoc On Demand Distance

#### ZigBee<sup>®</sup> Mesh Network



□ Static Nodes    ■ Gateway Nodes    ■ Mobile Nodes

Figure 1

Vector (AODV) routing protocol, provide greater stability in changing conditions (self-forming) or when single nodes fail (self-healing). In our ZigBee mesh network in Figure 1, we have three different types of nodes, all of them working on the same IEEE 802.15.4 physical link.

The gateway node (GN) is used to connect or interface our ZigBee network to an external computer or computer network (Figure 2). It is always wall-powered and non-mobile with significant computational power. These nodes are usually called ZigBee coordinators (ZC).

#### Example Board Setup for Gateway Node

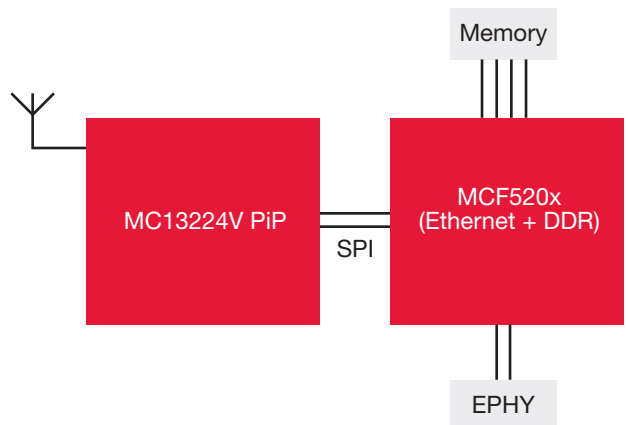

Figure 2

The static nodes (SN) are normally wall-powered and in a fixed known location (non-mobile) because they will act as references for the rest of the nodes that we want to locate (Figure 3). They too have higher computational power. SNs have a similar function to that of the satellites in a GPS system. These nodes are called ZigBee routers (ZR).

### Example Board Setup for Static Node

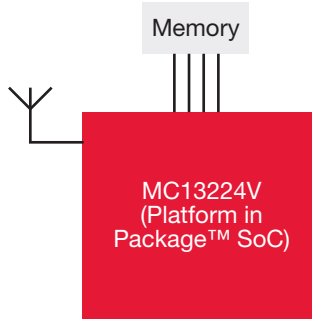

Figure 3

Finally, we have the mobile nodes (MN), which need to be battery-powered and as small as possible with lower computational capabilities (Figure 4). This is because they do not store network-wide information nor do they need to be able to perform network-related services. If you want to locate people inside a building, MNs can be worn as badges, bracelets or other form of accessory. In the case of a badge or ID application, these might even support memory cards to store information programmed by the user or an LCD display for easy human interfacing. An MN can either be a ZR or ZigBee end device (ZED).

### Example Board Setup for Mobile Node

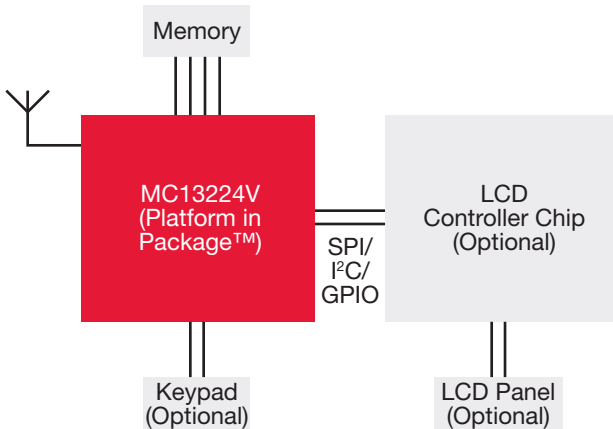

Figure 4

A keypad or LCD panel would be optional, for instance, when the MN is used as a tag to locate inventory in a hospital or school. (See the Position Location Application section for more details).

The SNs should be strategically located throughout the area to provide coverage for our position monitoring system. The more SNs the system has, the better it will perform.

Now we have all the pieces in place, but how does this low-cost, low-power, low-complexity local positioning system work? Let's go back to Figure 1. Imagine that mobile node 1 (MN1) needs to be located. You can see MN1 is in the vicinity (within its transmission radius) of three static nodes, so it is able to estimate its position using a multilateration technique, which can be based on range measurements taken using received signal strength indicator (RSSI) or by measuring the angle of arrival (AOA). AOA implies the use of multiple antennas, so that's why using range measurement based on RSSI is simpler and lower cost.

For ZigBee-based position monitoring systems it is important to have enough coverage for device triangulation. Remember, we need to get at least three distances from the SNs to the node we want to locate<sup>[9]</sup>. But what happens when an MN does not have a direct connection to an SN node?

Typical Wi-Fi-based location monitoring systems assume that a direct connection between the MN we want to locate and at least three reference nodes can be established at any time. In Figure 1 our ZigBee network shows that every MN has a direct connection to at least three SNs.

On the other hand, in Figure 5 shown below you can see another ZigBee mesh network where MN2 and MN3 only have a direct connection with two SNs. However, in this case, it is still possible to locate the two MNs because ZigBee technology offers a multihop routing capability. In other words, MN2 may establish a communication with and calculate the distance to the SN above MN3 using MN3 as an intermediate hop. It is important to highlight that in this case MN3 must be a node with ZR capabilities.

### Another ZigBee® Mesh Network

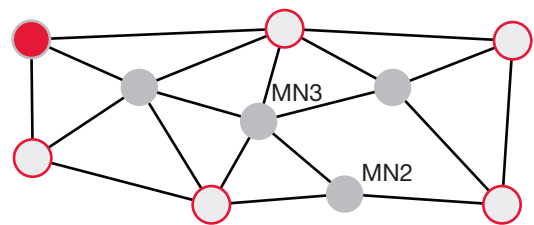

□ Static Nodes   ■ Gateway Nodes   ■ Mobile Nodes

Figure 5

Multihop position monitoring is a very important ZigBee capability.

## Wireless Technologies Comparison (ZigBee, Bluetooth, UWB, and Wi-Fi)

	ZigBee®	Bluetooth®	UWB™	Wi-Fi
Standard	IEEE® 802.15.4	IEEE 802.15.1	IEEE 802.15.3a (to be ratified)	IEEE 802.11 a, b, g (n, to be ratified)
Industry organizations	ZigBee Alliance	Bluetooth SIG	UWB Forum and WiMedia™ Alliance	Wi-Fi Alliance
Network topology	All	Star	Star	Medium dependent
Data rate	250 Kbps	723 Kbps	110 Mbps–1.6 Gbps	10–105 Mbps
Range	10–300m	10m	4–20m	10–100m
Power	Very low	Low	Low	High
Battery life	Alkaline (Months–Years)	Rechargeable (Hours–Days)	Rechargeable (Hours)	N/A
Max. nodes	65,000	8	128	32

Table 1

IEEE 802.15.4 radios provide very good “free-space” ranges up to 300 meters, which can be used to extend the coverage of the positioning system. For indoor applications, range drops to about 25–75 meters depending on building layout, contents and construction.

## ZigBee technology features and advantages

ZigBee technology has some important features that make it our best option to implement an ad hoc, on-demand, low-cost and low-power location monitoring system. Consider this—if you need battery-powered mobile nodes to implement an efficient location monitoring system, what happens if you have to change batteries every day? ZigBee’s low-cost, low-power capabilities help solve this issue and more.

ZigBee technology’s cost-effective features:

- Operating in 2.4 GHz unlicensed band or one of the sub-GHz regional bands
- Standards-based solution
- Specifically designed to support sensing, monitoring and control applications
- Low complexity (low memory footprint)
- Low power (battery operated devices)
- Mesh networking (a feature not found in most wireless networking standards)
  - Self healing
  - Self forming
  - Multihop routing protocol (AODV routing protocol)

In Table 1 you can see some of the ZigBee technology advantages over other wireless standards. Note that none of the others were designed to address monitoring or control applications.

## RSSI-based location monitoring algorithm

Using RSSI, the MN’s coordinates relative to the SN can be determined within some allowable error, typically less than three meters.

The RSSI-based location monitoring algorithm works in two phases<sup>11</sup>:

- Deterministic phase: This phase involves calibrating the RSSI values of each of the SNs whose location is known. Radio propagation patterns exhibit different non-isotropic path loss due to the various transmission mediums and directions. This is done using an MN. Raw RSSI values are collected at various predefined distances from the SNs, and the calibrated values are then used to determine a suitable propagation constant for each of the SNs.
  - Different mediums (free space, glass and wall) surrounding the SNs affect the signal attenuation differently. Therefore, if only a single propagation constant is used for all SNs, distance miscalculations occur. The calibrated propagation constant takes obstacles into account, and it is calculated as follows:

$$n_i = - \left[ \frac{\text{RSSI}_i - A}{10 \log_{10} d_i} \right]$$

where:

n: Signal propagation constant or exponent

d: Distance from sender

A: Received signal strength at 1 meter distance

- The value A is obtained in a no-obstacle one-meter distance signal strength measurement from the SNs.
- Probabilistic phase: This phase involves distance and position estimation using the propagation constant found in the above phase.
  - Distance estimation: This method is based on the fact that the mobile user does not move arbitrarily, rather there is a correlation between current positions and previous locations.

- Because the strength of the received signal varies dynamically, even if the MN is not moving, it is important to apply a low complexity smoothing algorithm to minimize the dynamic fluctuation of the radio signal received from each SN when the MN is moving. However, for a low-cost solution a coarse location of the subject under search would normally be sufficient.
- The basic assumption for this smoothing algorithm is that the constant velocity motion will result in a constant data change rate and stationary noise processes.
- The estimation and prediction stages for the smoothing algorithm are shown below:

Estimation:

$$\hat{R}_{est(i)} = \hat{R}_{pred(i)} + a \left[ R_{prev(i)} - \hat{R}_{pred(i)} \right]$$

$$\hat{V}_{est(i)} = \hat{V}_{pred(i)} + \frac{b}{T_s} \left[ R_{prev(i)} - \hat{R}_{pred(i)} \right]$$

Prediction:

$$\hat{R}_{pred(i)} = \hat{R}_{est(i)} + \hat{V}_{est(i)} T_s$$

$$\hat{V}_{pred(i+1)} = \hat{V}_{est(i)}$$

where

- $\hat{R}_{est(i)}$  : the ith smoothed estimate range,
- $\hat{R}_{pred(i)}$  : the ith predicted range,
- $R_{prev(i)}$  : the ith measured range,
- $\hat{V}_{est(i)}$  : the ith smoothed estimate range rate,
- $\hat{V}_{pred(i)}$  : the ith predicted range rate,
- a, b : gain constants,
- $T_s$  : time segment upon the ith update.

- Position estimation: To estimate the position of an MN, at least three SNs in the network must be able to detect and measure the MN's signal strength. Trilateration is a method used to determine the position of an object based on simultaneous range measurements from three SNs at known locations. The trilateration, otherwise known as the triangulation technique, is only the first step needed to estimate the position of the node of interest. For instance, if we have been able to measure distances from three SNs, then we will have a triangle, but we have to find the centroid of that triangle to get the initial position of the node we want to locate. We can then initiate one of the well-known location estimation iterative methods.

- Iterative methods, such as weighted linear least squares or maximum likelihood, are applied to derive the MN position according to the estimated distance resolved from filtered RSSI and the calibrated constant. The algorithm requires the coordinates of at least three SNs ( $x_i, y_i$ ) and the distances ( $d_i$ ) between the MN and the respective SNs, which are estimated in the deterministic phase.
- The error estimated is corrected in the estimation. The iteration is repeated until the error is acceptable.

The complete flow of MN estimation of location is shown in the flowchart in Figure 6.

### RSSI-Based Position Location Algorithm

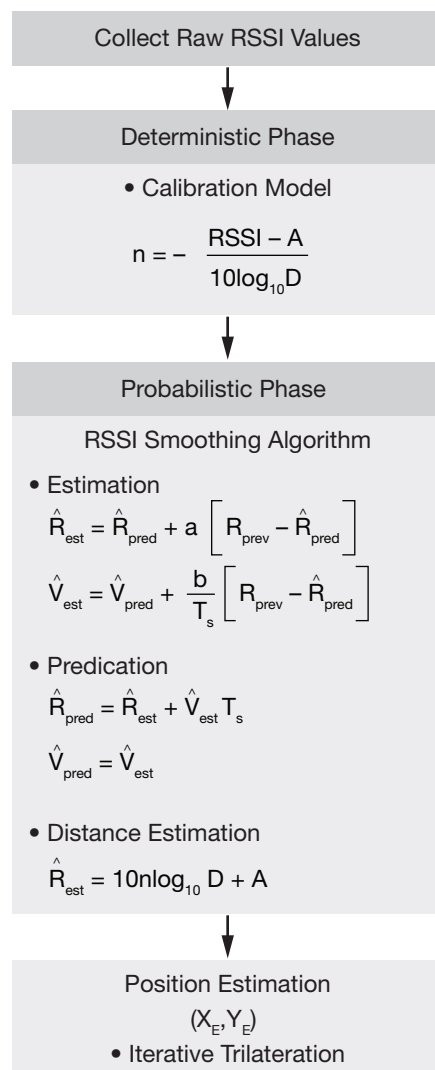
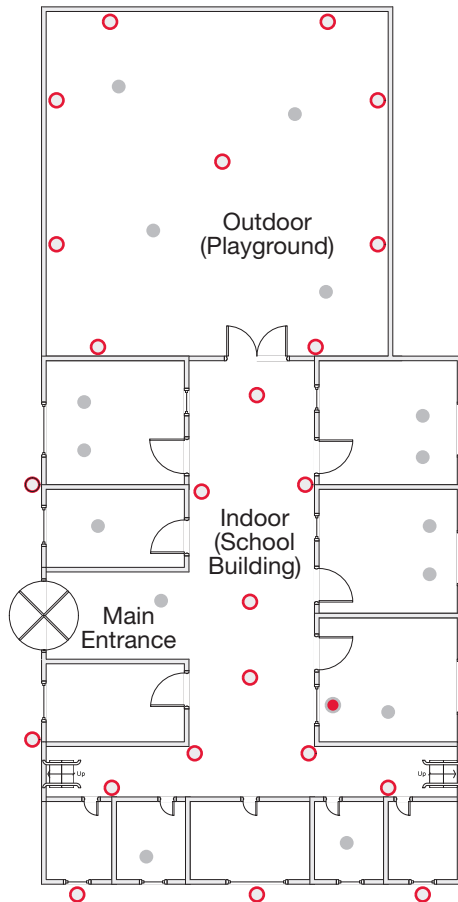

Figure 6



□ Static Nodes    ■ Gateway Nodes    ■ Mobile Nodes

Figure 7

## Position location application

Position location monitoring can be used in the following applications.

### Location monitoring

This application is designed to help school authorities, for instance, keep track of school children while they are on school premises and even locate teachers in case of an emergency.

Figure 7 illustrates sample placements of the three types of nodes in both the indoor and outdoor school environments.

In the above layout, the gateway node is placed in the administration office. In case of multiple floors, each floor may have a gateway node, and all gateway nodes could be networked to the main computer in the administrative office. Static nodes are scattered around the building in such a way that blind spots (i.e. portions not detected by a static node) are minimized and maximum coverage is obtained. The goal is to ensure any mobile node is continuously in contact with three static nodes.

The MNs are embedded in student and teacher ID cards, which ID holders wear at all times while in the school. The gateway node periodically sends out broadcast messages to static nodes to update network information.

Using this network, the school administration can:

- Track student activities
- Broadcast messages about different events, such as school assemblies
- Monitor the time a child spends in certain activity areas and develop a report on his or her behavior for school and parental review
- Automate student attendance records
- Contact teachers when their assistance is needed

If any student is not in a classroom or needs to be located, the teacher can simply type in the student's ID on any computer connected to the GN through the mesh network or even the Internet. The GN would then instruct the SNs to obtain the position of that particular ZigBee mobile node ID.

### Patient monitoring

This application is similar to the school application, and can be used to:

- Monitor patients in different rooms and transmit their vital statistics to a central server (connected to the GN), which can forward those to the doctor in charge
- Ping doctors and medical staff to locate them faster
- Help new patients and employees navigate through the hospital premises
- Monitor the hospital's inventory to locate stored items more quickly
  - In this case the mobile node requires less functionality because it does not need any display or keyboard buttons. The MNs are simple tags that can be attached to the hospital inventory for quick location in an emergency, which can save time critical to patient care

### Local navigation

This application can work in tandem with the local positioning system explained in the previous section. Because the GN contains all network information, it can help a person with an MN navigate to a specific destination in the building. The user would enter a location from a preset menu, then the navigation software built on top of the MN's local position monitoring capabilities can guide the user to the desired location.

### Information exchange

A similar setup can be used for a big event spread over a huge area, where attendees and organizers would be given ID cards that would act as MNs in the network. In addition to monitoring people and helping them navigate through the maze of booths and conference halls, an additional application can be built into the ID Cards which can help people exchange business and

contact information. Through a scrollable menu, the user can select from any of the following application features (Figure 8):

- Find people
  - Similar to student location and patient monitoring
  - Can help to track administrative people or fellow seminar attendees
- Locate a room or hall in the event area using a local navigation function
- Exchange contact information and notes
  - Allow users to exchange contact information, notes (large messages could be broken into smaller ones and then reassembled after receipt) and business cards, which could be downloaded to a PC at the event and transferred to a CD or flash drive for personal use
  - Sending short messages to fellow attendees or organizers

### Sample Design of ZigBee® Enabled ID Card

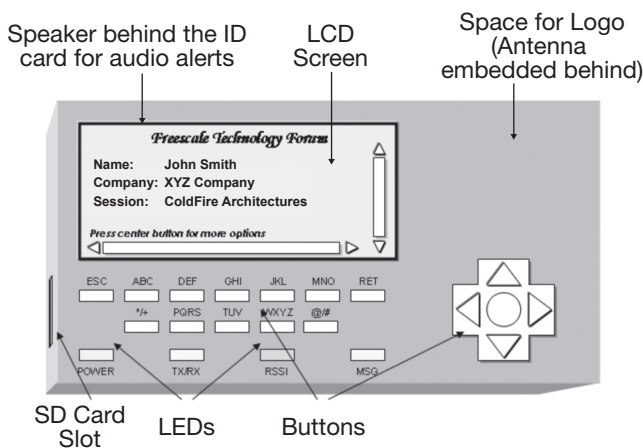

Figure 8

## Freescle enables location monitoring with ZigBee technology

Freescle has an extensive portfolio of ZigBee-enabled ICs and low-power microcontrollers (MCUs) that make up the ideal platform for ZigBee-enabled networks.

Freescle's MC13224V ZigBee Platform in Package™ (PiP) is the latest of our low-power platforms for ZigBee devices. The highly integrated MC13224V PiP simplifies RF design, allowing many customers who do not have extensive RF experience to still create robust ZigBee-enabled designs. Freescle also has a number of reference designs that include the design details for the hardware in the development kits. You can take the bills of materials, Gerber files and schematics and either copy our design or integrate it into yours. The complete platform approach helps reduce development time and speed time to market.

### MC13224V PiP key features include:

- IEEE 802.15.4 standard-compliant on-chip transceiver/modem
  - 2.4 GHz
  - 16 selectable channels
  - Advanced encryption/decryption hardware engine (AES 128-bit)
- Low power
  - 21 mA typical current consumption in RX mode with MCU active
  - 29 mA typical current consumption in TX mode with MCU active
- 32-bit ARM7TDMI-S™ CPU core with programmable performance up to 26 MHz (24 MHz typical)
- Extensive on-board memory resources
  - 128 KB serial flash memory (can be mirrored into RAM)
  - 96 KB SRAM
  - 80 KB ROM
- Best-in-class power dissipation
- Extensive MCU peripherals set
  - Dedicated NVM SPI interface for managing flash memory
  - Two dedicated UART modules capable of 2 Mbps with CTS/RTS support
  - SPI port with programmable master and slave operation
  - 8-pin keyboard interface (KBI) supports up to a 4x4 matrix
  - Two 12-bit analog-to-digital converters (ADCs) share eight input channels
  - Up to 64 programmable I/O shared by peripherals and GPIO
- No external RF components required
  - Only an antenna is needed for single-ended 50Ω RF interface (balun in package)
  - Only a crystal is required for the main oscillator; programmable crystal load capacitors are on-chip
  - All bypass capacitors in package

For further details, please see the MC13224v reference manual<sup>[2]</sup>.

Freescle's BeeStack™ ZigBee-compliant stack with BeeKit™ Wireless Toolkit provides a simple software environment to configure network parameters. This tool is unique to Freescle, allowing customers to use a wizard and drop down menus to help configure the ZigBee network parameters.

Freescle's MC13224V ZigBee Evaluation Kit (Part #1322xEVK) is specifically targeted for developing ZigBee-enabled products, providing the necessary hardware and software tools to streamline the development process. For customers running the ZigBee protocol who require a different low-power MCU, they can combine the MC13202 RF transceiver and the Flexis QE128 MCU. The MC1320x-QE128-DSK provides a simple and cost-effective development platform.

