

Applications Enabled by High-Performance Hybrid Controllers

Bill Hutchings

1. Introduction

1.1 Overview

This paper will first review the features and benefits of performance-leading 56F8300 Digital Signal Controllers (DSCs), then investigate some applications now enabled by these revolutionary controllers. Freescale's digital signal controllers and microcontrollers have a long and distinguished history in industrial and control applications. The new 56F8300 Series is the latest addition to the widely adopted 56F800 portfolio of high-performance, Flash-based controllers. The 56F8300 devices combine the capabilities of a microcontroller with the signal processing performance of a Digital Signal Processor (DSP), and the raw protocol and control processing power of a 32-bit RISC. Some of the features and benefits of the 56F8300 solutions that this paper will explore are:

- **Exceptional integration of powerful internal peripherals**--significantly lowers system costs
- **High-performance, reliable internal Flash memory**--offers flexibility in development, production and inventory with the reliability and performance traditionally associated with read-only memory
- **High 60MHz/60 MIPS performance**--enables a broad range of applications at a lower cost
- **Hybrid MCU/DSP core architecture**--speeds development and lowers component count
- **Integrated safety features for high reliability**--creates safer, lower-risk, more reliable end products
- **Extended temperature operation**--allows innovative end products that can be used in the harshest environments

Contents

1. Introduction.....	1
1.1 Overview.....	1
2. Applications Enabled by the 56F8300 Controller	9
2.1 Network-enabled, High-performance UPS.....	9
2.2 High-Performance Switched-Mode Power Supply.....	11
2.3 Digital By-wire and Power-Assist Systems.....	13
2.4 Intelligent Sensor Applications.....	18
3. Conclusions.....	20

- **Powerful, award-winning CodeWarrior™ Integrated Development Environment**--lowers software development costs and frees your software developers
- **Innovative Processor Expert™ rapid application development tool**--dramatically speeds software development and the developer's learning curve

These elements mean that the 56F8300 Series of components is ideally suited for a broad range of industrial applications. The 56F8300 Series is a part of the greater Freescale Embedded Flash portfolio, as shown in **Figure 1-1**.

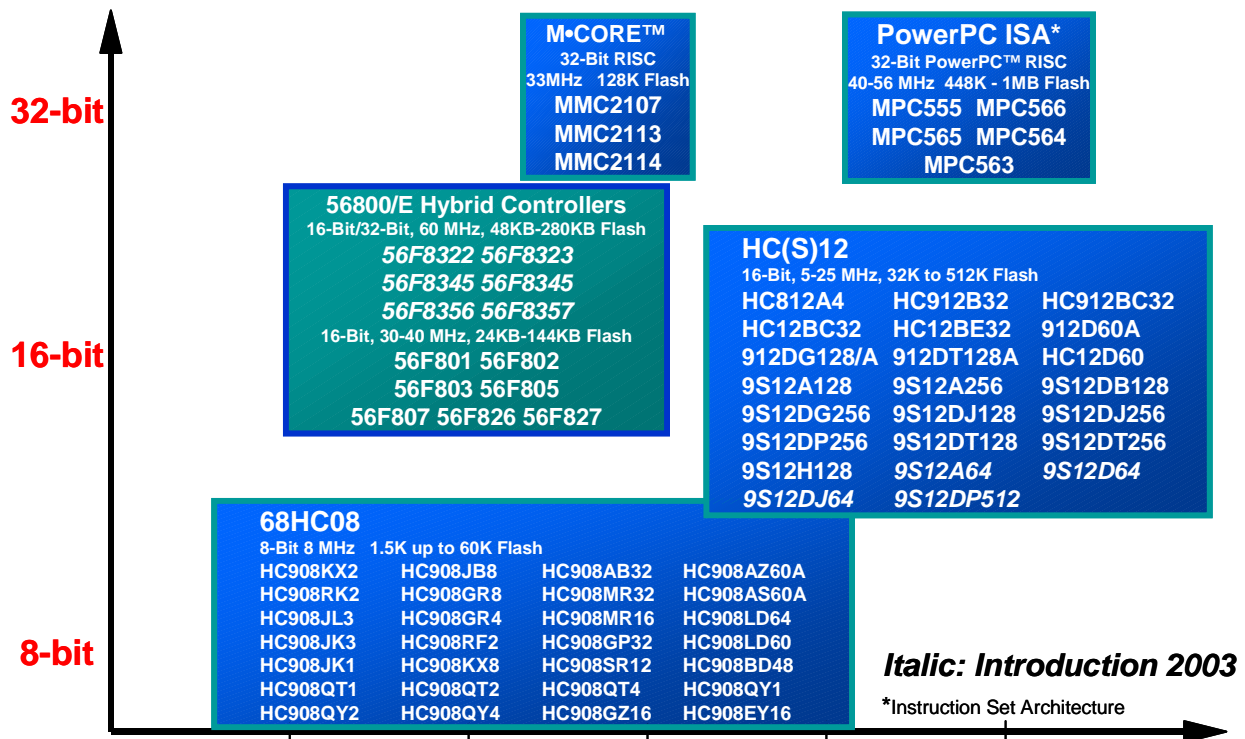

Figure 1-1. Freescale's Controller Continuum

Figure 1-2 illustrates the broad portfolio of 56800/E components; all are code compatible. The 56F800 Series is based on the original 56800 core and offer the best of both MCU and DSP functionality. The 56F8300 Series is based around the enhanced version of the 56800 core, the 56800E, and offers improved DSP and MCU performance, as well as improved 32-bit capability. The 56850 Series is RAM-based and targeted for high performance voice, multimedia, telecom, and hybrid networking applications.

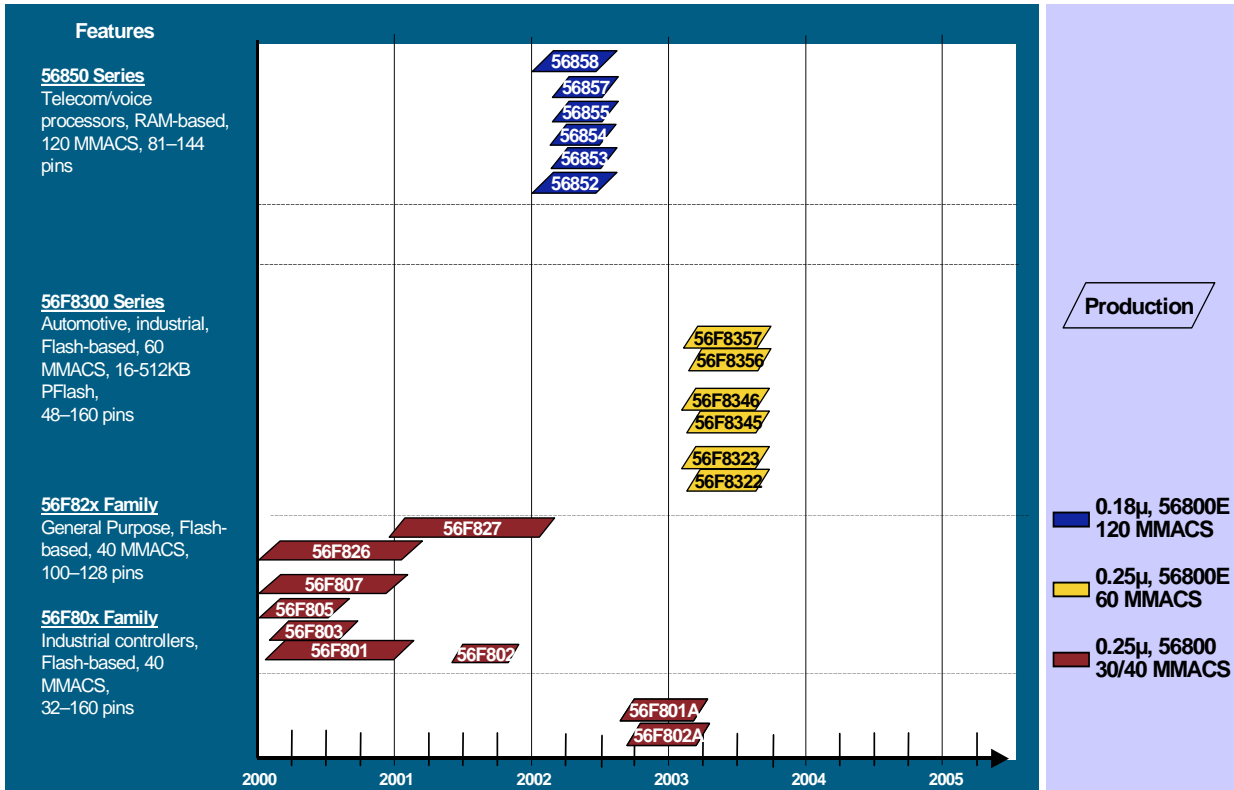
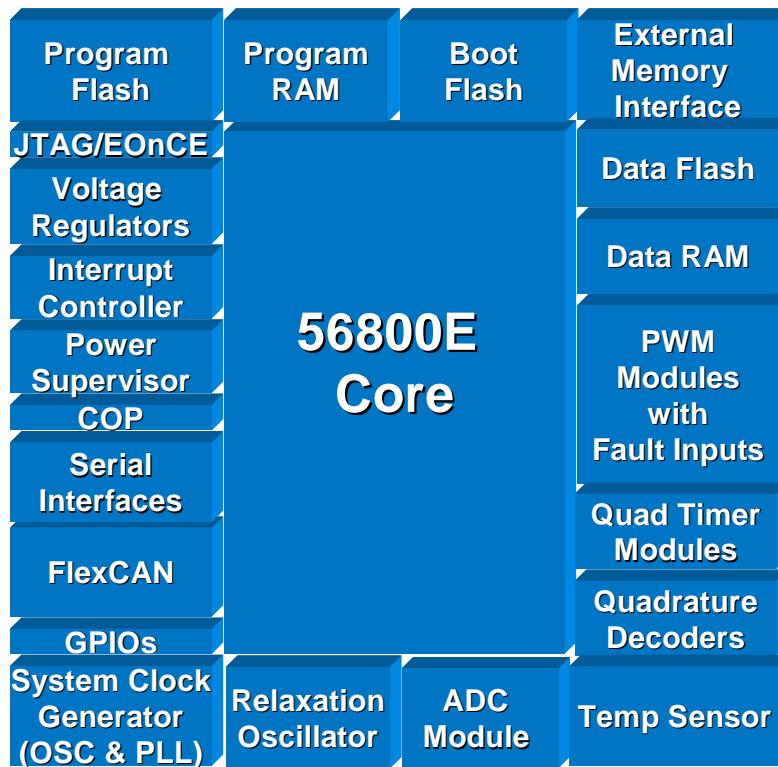

Figure 1-2. Freescale Digital Signal Controller Portfolio

The 56F8300 devices are the highest-performance Flash-based hybrid digital signal controllers in the portfolio. The components in the 56F8300 Series have a broad range of package, memory, and peripheral configurations. **Table 1** and **Figure 1-3** show the details of the 56F8300 portfolio.

Table 1. 56F8300 Portfolio Details

	56F8322	56F8323	56F8345	56F8346	56F8356	56F8357
Performance	60MHz	60MHz	60MHz	60MHz	60MHz	60MHz
Temperature Range	-40°C to +105°C or -40°C to +125°C	-40°C to +105°C or -40°C to +125°C	-40°C to +105°C or -40°C to +125°C	-40°C to +105°C or -40°C to +125°C	-40°C to +105°C or -40°C to +125°C	-40°C to +105°C or -40°C to +125°C
Voltage (Core / I/O)	2.6V / 3.3V	2.6V / 3.3V	2.6V / 3.3V	2.6V / 3.3V	2.6V / 3.3V	2.6V / 3.3V
Program Flash	32KB	32KB	128KB	128KB	256KB	256KB
Program RAM	4KB	4KB	4KB	4KB	4KB	4KB
Data Flash	8KB	8KB	8KB	8KB	8KB	8KB
Data RAM	8KB	8KB	8KB	8KB	16KB	16KB
BootFlash	8KB	8KB	8KB	8KB	16KB	16KB
Flash Security	Yes	Yes	Yes	Yes	Yes	Yes
External Memory Interface	No	No	No	Yes	Yes	Yes
Regulator (On-Chip / Off-Chip)	On-Chip	On-Chip / Off-Chip	On-Chip / Off-Chip	On-Chip / Off-Chip	On-Chip / Off-Chip	On-Chip / Off-Chip
On-Chip Relaxation Oscillator	Yes	Yes	No	No	No	No
Quad Timer	2	2	4	4	4	4
Quadrature Decoder	1 x 4 channel	1 x 4 channel	2 x 4 channel	2 x 4 channel	2 x 4 channel	2 x 4 channel
PWM	1 x 6 channel	1 x 6 channel	2 x 6 channel	2 x 6 channel	2 x 6 channel	2 x 6 channel
PWM Fault Input	1	3	4 + 4	3 + 4	3 + 4	4 + 4
PWM Chip Select Pins	0	3	3+ 3	3+ 3	3+ 3	3+ 3
12-bit ADC	2 x 3 channel	2 x 4 channel	4 x 4 channel	4 x 4 channel	4 x 4 channel	4 x 4 channel
Temperature Sensor	Yes	Yes	Yes	Yes	Yes	Yes
FlexCAN	1	1	1	1	1	1
SCI (UART)	2	2	2	2	2	2
SPI (Synchronous)	2	2	2	2	2	2
GPIO (Maximum)	21	27	49	62	49	76
JTAG/EOnCE	Yes	Yes	Yes	Yes	Yes	Yes
Package	48 LQFP	64 LQFP	128 LQFP	144 LQFP	144 LQFP	160 LQFP



Package: From 48 up to 160 pin LQFP

Figure 1-3. 56F8300 Block Diagram

The 56F8300 Series offers an excellent complement of peripherals and a broad range of memory and packages. Some of the 56F8300 Series' benefits include:

- **High performance 56800E core**
 - Superior 16-bit, fixed-point signal processing performance provided by the bus architecture and the hybrid controller core
 - Excellent control and protocol processing capability and code density
 - Superior 32-bit performance provided by the internal 32-bit-wide buses and registers
- **Performance-leading Flash memory**
 - Unbeatable, field-proven reliability in the harshest environments
 - Features that enable emulation of EEPROM
 - Flexible, full in-circuit Flash programmability
 - Performance-enhancing interfacing and bus structure, enabling the greatest signal processing capability from Flash in the controller continuum portfolio
 - Flash block protection features for IP protection

- **Flexible External Memory Interface (EMI)**
 - Some 56F8300 devices include a flexible External Memory Interface that enables glueless connection with programmable chip selects and separate wait state generation, allowing the most cost-effective and lowest possible chip count when interfacing to external memory or peripherals
 - The EMI interface can be configured as GPIO
- **Voltage regulator and power supervisor**
 - The chips come equipped with an on-board voltage regulator and power supervisor. When supplied with a 3.3V voltage, the chip creates all required internal voltages
 - Includes features such as Power-On Reset (POR) and low-voltage detection, eliminating external components and saving system costs
- **On-chip Relaxation Oscillator**
 - Some 56F8300 devices are equipped with a precision on-chip, factory-trimmed oscillator (0.25% of 8MHz), enabling the elimination of an external crystal and providing system cost savings
- **On-Chip Clock Synthesis (OCCS)**
 - 56F8300 controllers are equipped with on-chip crystal and ceramic resonator oscillator drive circuitry, enabling the direct connection of an external crystal or ceramic resonator
 - The OCCS capability includes a flexible, programmable Phase Locked Loop (PLL), enabling selection of an exact operating frequency
 - The OCCS also includes unique loss-of-lock detection, allowing the detection of a cut crystal and the proper safety-critical shut down
- **Quad Timer**
 - 56F8300 devices are equipped with powerful timer modules. Each timer module has four independent 16-bit timers that can be:
 - Cascaded
 - Used for input capture
 - Used to generate output waveforms
 - Used to trigger the ADC
 - Used to generate auxiliary PWM waveforms
 - Used as a Digital-to-Analog Converter (DAC) when utilized in conjunction with an external low-pass filter
- **Quadrature Decoder**
 - Full-featured, four-input decoder with:
 - 32 bit directional position tracking
 - Programmable digital filtered inputs
 - Integral watchdog timer to flag a non-rotating shaft condition
 - Ability to calculate velocity measurement

- **3-Phase PWM module**
 - The high-performance 15-bit PWMs can be used in edge-aligned and center-aligned modes, as well as in complementary and independent modes and have programmable dead-time generation
 - These PWM modules have a sophisticated set of programmable fault lines that do not require a system clock for proper operation
 - These and other features make these PWM modules industry leaders in safety, reliability, and performance
- **Analog-to-Digital Converter (ADC) Module**
 - Each high-performance 12-bit ADC has two sample and hold circuits, enabling simultaneous or sequential conversion at a rate of up to 1.2 μ s per conversion
 - ADCs can be used in single-ended or differential modes and have a sophisticated set of unique features, including:
 - Self-calibration
 - H/low and zero crossing detection
 - Power-saving modes
 - ADCs can be triggered through variety of methods, including PWM synchronization
 - ADC inputs have on-chip current protection circuitry, enabling their use in the harshest of industrial applications
- **Temperature Sensor**
 - Enables the measurement of the device's operating temperature, which can be important in safety-critical or harsh temperature environments
 - Highly accurate sensor which can measure 1 $^{\circ}$ C increments
 - Each component is factory-calibrated for reliable operation
 - The temperature sensing function can be configured to provide an interrupt when a certain threshold is reached, detecting overheating with zero overhead
- **FlexCAN**
 - This powerful second-generation Controller Area Network (CAN) module is fully compliant with version 2.0 A/B
 - Features include:
 - Time stamps based on a 16-bit, free-running timer
 - Programmable wake-up functionality with integrated low-pass filter
 - 16 Transmit (TX) / Receive (RX) buffers
 - This peripheral enables the reliable and flexible networking of processors and intelligent devices at speeds up to 1Mbps
- **Serial Communication Interface (SCI)**
 - This module operates as a full duplex Universal Asynchronous Receiver Transmitter (UART)
 - Fully interrupt driven and programmable, providing a multitude of operating modes and baud rates

- **Serial Peripheral Interface (SPI)**
 - This synchronous serial interface is double-buffered
 - Operates in wide variety of modes, rates, and bit lengths, enabling the glueless connection to external peripherals and other processors at rates up to 30Mbps
- **General Purpose Input/Output (GPIO)**
 - All digital pins for the on-board peripherals can also be individually assigned to be GPIO and individually assigned a direction
 - In addition to I/O capability, the GPIO can also generate interrupts
 - Each GPIO has programmable pull-ups
 - The GPIO also has a push-pull mode to efficiently implement a keypad interface
- **Computer Operating Properly (COP)**
 - Assists software recovery from runaway code
 - The COP is a free-running down counter which, once enabled, is designed to generate a reset when reaching zero
 - Software must periodically service the COP to clear the counter and prevent a reset
 - The COP enhances end system reliability and safety
- **JTAG/EOnCE™**
 - This enhanced on-board emulation module enables true full-rate emulation without the need for expensive hardware emulators
 - To perform powerful, non-intrusive, real-time debugging, simply attach to the processor with the industry-standard JTAG interface

The 56F8300's truly impressive set of features demonstrates why Freescale is the world leader in embedded processors. These components are applicable to a broad range of industrial and automotive applications, such as:

- Compressors
- Smart appliances
- Home security
- Instrumentation
- Data acquisition
- Factory automation
- Metering
- Industrial networking
- Lifts / elevators / cranes
- HVAC blowers & fans
- Uninterruptible Power Supplies (UPS)
- Switching power supplies
- Hydraulics replacement

2. Applications Enabled by the 56F8300 Controller

The 56F8300 Series is a very capable product line with excellent performance and a very high level of peripheral and memory integration. In addition, the 56F8300 devices are very affordable. The power and affordability offered by the 56F8300 Series enable new applications as well as new features to existing products. This white paper details a few of these applications.

2.1 Network-enabled, High-performance UPS

Uninterruptible Power Supplies (UPS) have been widely used for office equipment, computers, communication systems, medical/life support and many other systems. The goal of UPS is to provide clean and continuous power to a load, regardless of power grid conditions. Customers are demanding new levels of reliability, performance, and connectivity in these UPS products. Among the new requirements are a target expectation for UPS reliability of 99.999% power availability, performance demands of zero switch over time, and complex network connectivity and control methods, such as simple network management protocol (SNMP). Market pressures are driving UPS prices down at the same time these more-difficult requirements must be met. To satisfy these new and complex demands, new UPS topologies and solutions are required. Among the various UPS topologies, on-line triple-conversion UPS provides both clean and uninterruptible power to the load and satisfies the reliability and performance requirements. Since an on-line UPS always stays in active mode, the output voltage can remain stable, regardless of input voltage sag or power failure. It can provide stable, glitch-free AC power with fixed frequency and no switching time. Another benefit of on-line triple-conversion UPS is that battery life can be significantly extended compared to other on-line UPS topologies. To improve availability and avoid a single point failure, the new requirements for UPS are scalable architectures, the ability to hot-swap UPS modules and batteries, high power densities and networking capability.

The 56F8300 controller family is an excellent choice as the processing and control engine required for this advanced UPS architecture. A 56F8300 controller uniquely offers the features needed to support the required functions cost effectively. These features include:

- 56F8300 MCU features supporting the network stacks and control processing
- 56F8300 DSP features supporting the signal processing required for UPS algorithms
- Advanced PWM and ADC peripherals supporting AC-to-DC conversion, DC-to-AC conversion, and battery charge without the need for external components
- Superior on-chip Flash supporting SoC design that can be used reliably in the harshest environments

An on-line triple-conversion UPS block diagram is shown in [Figure 2-1](#). During normal operation, the AC input voltage is rectified by an AC/DC converter which not only rectifies the input voltage but also regulates the input power factor. The output of the AC/DC converter is a DCBus voltage that is used as the source for both the battery charger and DC/AC inverter. The battery charger is a boost/buck DC/DC converter. When the system is charging the batteries, the DC/DC converter works in buck mode, which steps the high DCBus voltage down to the batteries acceptable voltage level and charges the batteries. When the battery pack is fully charged, the converter switches to standby mode. If an input power failure occurs, the DC/DC converter works in boost mode, which supplies power to the DCBus from the batteries. The DC/AC inverter is used to convert the DC voltage to approximated sinusoidal output voltage pulses. The pulse string is input to an LC filter, which generates a true sinusoidal output voltage that is supplied to the load. The frequency of the sinusoidal output voltage is selectable by the user and can either be synchronized to the input voltage frequency or to any other desired independent stable frequency. When any failures or faults are generated or maintenance is needed in the UPS system, the bypass switch will be engaged, which turns the UPS system off and connects the load directly to the input power source.

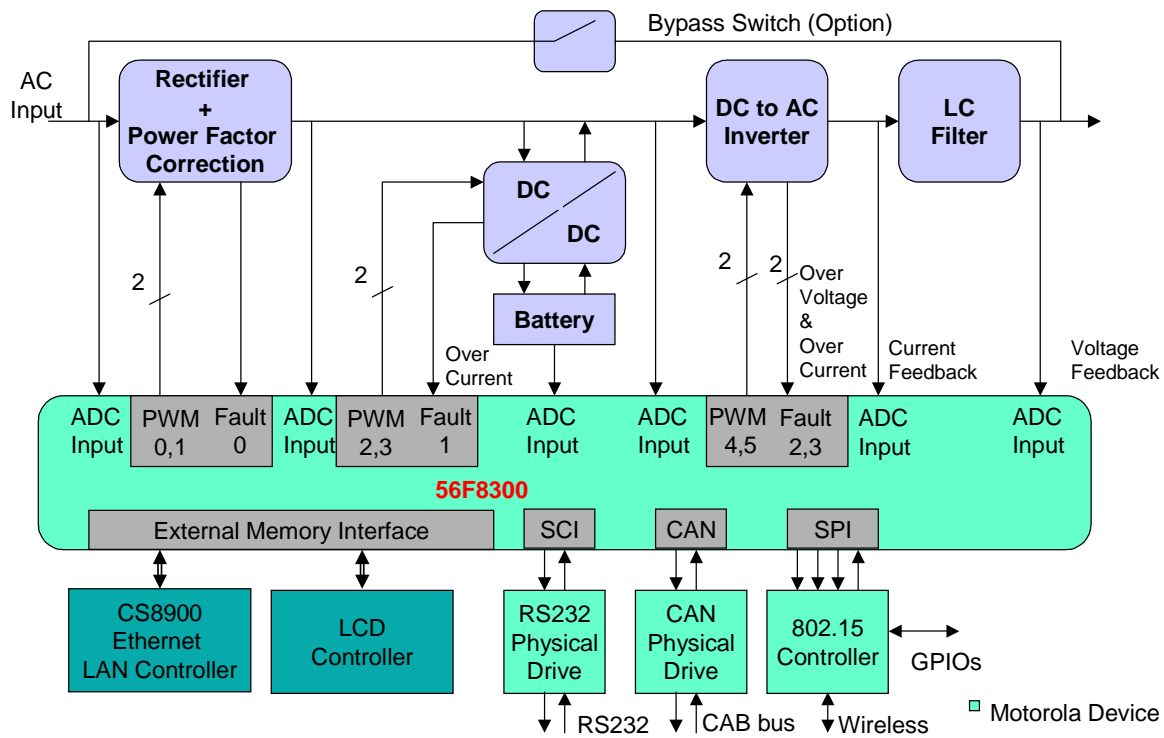

Figure 2-1. Network-enabled UPS Hardware Diagram

Figure 2-2 shows the implementation of the functional blocks in a triple-conversion on-line UPS system. The power stages interface to the 56F8300 via gate drivers. All necessary control functions are implemented within the 56F8300, such as:

- Power on/off control
- DCBus voltage regulation
- Input power factor correction
- Battery management
- AC output voltage regulation
- Frequency synchronization of input and output
- Power source monitoring
- System self-diagnostics and self-protection
- Emergency event processing
- Real-time multi-tasking system operation
- Communication protocols

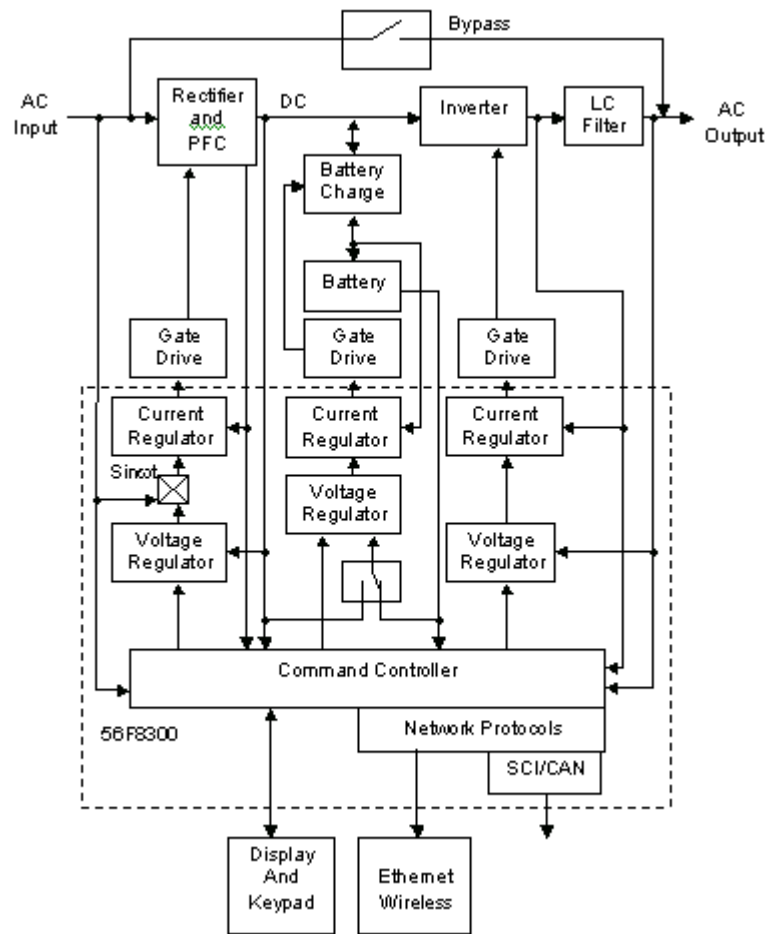

Figure 2-2. UPS Functional Block Diagram

The 56F8300-controlled UPS will minimize the number of system components, maximize the system reliability and enable the easy addition of advanced functions, without increasing cost. The key advantages of a hybrid-controlled UPS are:

- Bi-directional AC-DC conversion
- High-input power factor and lower power pollution to the power grid
- Extended battery life
- Power source and load conditioning can be monitored in real time
- Network communication
- Lower maintenance cost

The 56F8300 is an excellent and very cost-effective choice for use in high-performance UPS systems.

2.2 High-Performance Switched-Mode Power Supply

The main purpose of a power supply is to provide clean and stable power to a load, regardless of power grid conditions. The Switched-Mode Power Supplies (SMPS) has been widely used in office equipment, computers, communication systems and other applications because of its high efficiency and high energy density.

Presently, the vast majority of SMPS are performed in an analog fashion. But analog implementations have some significant disadvantages that can be rectified by implementing the SMPS using modern digital mechanisms. Until recently, this has not been cost effective, due to performance and cost of the processors required to do the job. The 56F800 and 56F8300 Series of controllers have the required performance, peripherals, and price targets to enable SMPS to make the conversion from analog-to-digital implementations.

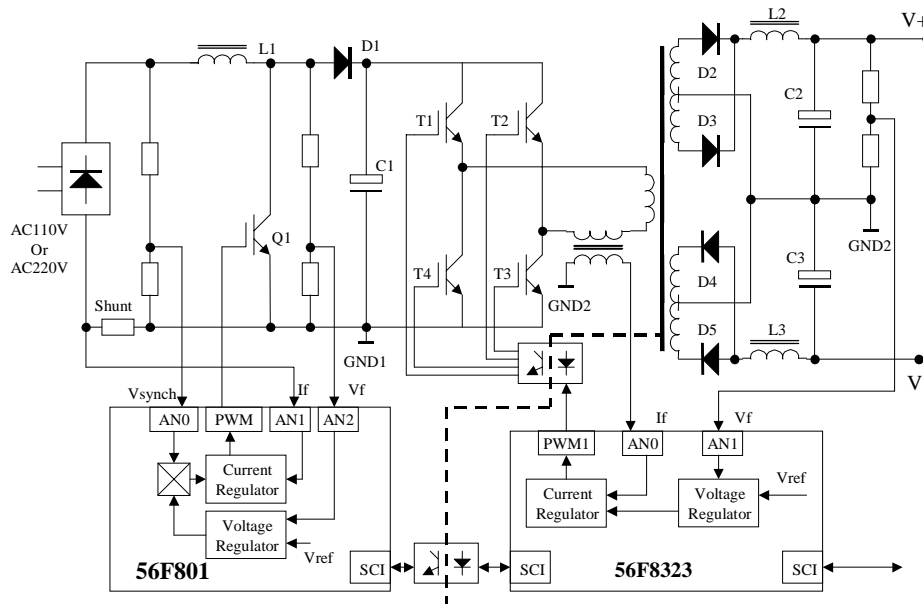

Figure 2-3. Example Digital SMPS

A block diagram for a 56F800/56F8300-based switched-mode power supply is shown in [Figure 2-3](#). The system in this example is a 100-Watt switched-mode power supply controlled by a 56F801 on the primary side and a 56F8323 on the secondary side. Optional components could include user interfaces, such as an LCD or LED display.

During normal operation, an AC/DC rectifier controlled by a 56F801 will correct the input power factor while simultaneously rectifying the AC input voltage. The output of the AC/DC rectifier is a DC voltage that will feed the DC/DC converter, which is controlled by a 56F8323. The DC/DC converter has a full bridge topology, used to convert the DCBus voltage to a precise and constant DC output voltage. For the Power Factor Correction (PFC) converter, the 56F801 samples the input AC voltage, input AC current, and DC output voltage. The output DC voltage is regulated by the 56F801, while maintaining the same phase for both the AC input current and voltage. The PWM module on the 56F801 produces the PWM pulse for the PFC main power component. The DC/DC converter controlled by the 56F8323 is operating on a phase-shifted soft-switching mode, so that switching losses and noise can be kept to a minimum.

Control functions implemented within the secondary controller are:

- Power on/off control
- DCBus voltage regulation
- Output DC voltage regulation
- DC/DC full-bridge phase-shifted control strategy

- Power system monitoring and communication protocols (optional)
- Fault and mode management

Control functions implemented within the primary controller are:

- Input power factor correction
- Automatic detection of input voltage frequency

The digital 56F8300 Switched-Mode Power Supply minimizes the number of system components, maximizes the system reliability, and makes it possible to easily add advanced functions without increasing cost. The key advantages of this digitally controlled SMPS are:

- Power applications become more flexible and universal
- High input power factor lowers power pollution to the power grid
- Intelligent mode management and fault supervision
- Operating status can be monitored and controlled in real time
- Lower system and maintenance cost

The 56F8300 and 56F800 performance, integrated peripherals, and low cost make the digital SMPS possible and practical.

2.3 Digital By-wire and Power-Assist Systems

With the introduction of the 56F8300, a new set of control applications is now possible that will revolutionize the way vehicles and heavy equipment are designed, maintained, and used. Currently, a large number of hydraulic control systems in vehicles and heavy equipment are used to transform human inputs from foot pedals, steering wheels, and hand levers to power-assisted mechanical control action on brake pads, engines, wheels, pulleys, and other mechanical elements. Today, through the use of the 56F8300 advanced digital signal controllers, these hydraulic control systems can be replaced with digital electro-mechanical systems. The general benefits are many and significant and include:

- Lower system costs
- Lower maintenance costs
- Higher reliability
- Lighter and smaller systems
- More intelligent systems, allowing control algorithms only available using digital methods
- Easier modification and lower development costs
- Better engine performance
- Environmentally friendly

These benefits are achieved by replacing traditional mechanical hydraulic components and subsystems with electrical components and subsystems. The electrical components are less expensive, lighter, more reliable, and more maintenance-free than the hydraulic mechanical components and subsystems they replace. The digital by-wire systems enable much greater flexibility and intelligence because they are driven by microprocessors, such as the 56F8300 controllers, that are programmed via software. The most basic nature of the system's operation is software-controlled, making it very easy to update for new functionality and customize for any given end product. This ease of update and customization is simply not possible in physical hydraulic systems. The improved engine performance is achieved because the electro-mechanical systems do not siphon as much of the engine power as the hydraulic systems do to perform the same task. This greater

efficiency enables the engine to operate with better fuel performance or to transfer more power to the main engine task and less to the control systems. Since hydraulic fluid is not required, this environmentally hazardous material can be eliminated from the system.

The 56F8300 Series is uniquely well-suited for use in digital electro-mechanical systems. These components have all the elements critical to implementing these electro-mechanical systems in a cost-effective way, including the required integrated high-performance peripherals such as PWM, encoders, CAN, ADC, and internal Flash memory. The 56F8300 controllers also have the signal processing power required by advanced motion algorithms, the MCU capability for the control code, and the raw processing power required by these sophisticated systems.

Most importantly, the 56F8300 processors meet the requirements of safety-critical applications. Many of the hydraulic systems that are to be replaced are used in end systems in which their improper operation could cause physical harm to humans. These types of systems, termed safety-critical, must operate properly at all times. A 56F8300 device has many features that make it easier and less expensive to implement safety-critical applications. These include extensive fault analysis and factory testing of the internal structure of the components to ensure that every component delivered to a customer will operate to the data sheet's specifications. Also, the features of the 56F8300 devices, such as the internal temperature sensor, fault inputs, and internal self-checking circuitry, ensure that the components are operating correctly. The 56F8300 controllers are designed and tested to enable their use in the harshest operational environments. Freescale Semiconductor, Inc, the leading supplier of embedded processors to the automotive industry, has been in the business for many years and, as such, is uniquely qualified to develop and supply processors for safety-critical applications in harsh environments.

The following sections contain specific examples where hydraulic systems are replaced with digital electro-mechanical ones.

2.3.1 Electric Power-Assisted Steering

Figure 2-4 shows a block diagram of digital electric power-assisted steering system. This system replaces a hydraulic-based power steering system for automobiles and steered industrial heavy equipment. In the example shown, the electro-mechanical system performs a power assist similar to the one performed by a hydraulic system. A mechanical connection exists between the steering wheel and the tires, with the digital electric system amplifying the force supplied by the human driver. A by-wire steering system would entirely remove the physical mechanical connection between the steering wheel and the tires, with total control provided by the 3-phase electric motor. The steering wheel generates the torque command, and the electric motor provides the steering assistance to overcome the load. The 56F8300's internal PWM directly drives the 3-phase power stage that powers and controls the motor. The internal ADC inputs the feedback signals from the motor, such as the current sense and resolver. The quad timer also gets feedback on the motor shaft position from the encoder. The internal CAN peripheral is used to connect into the vehicle's real-time control network. The internal temperature sensor constantly checks to ensure the proper operating temperature is not exceeded.

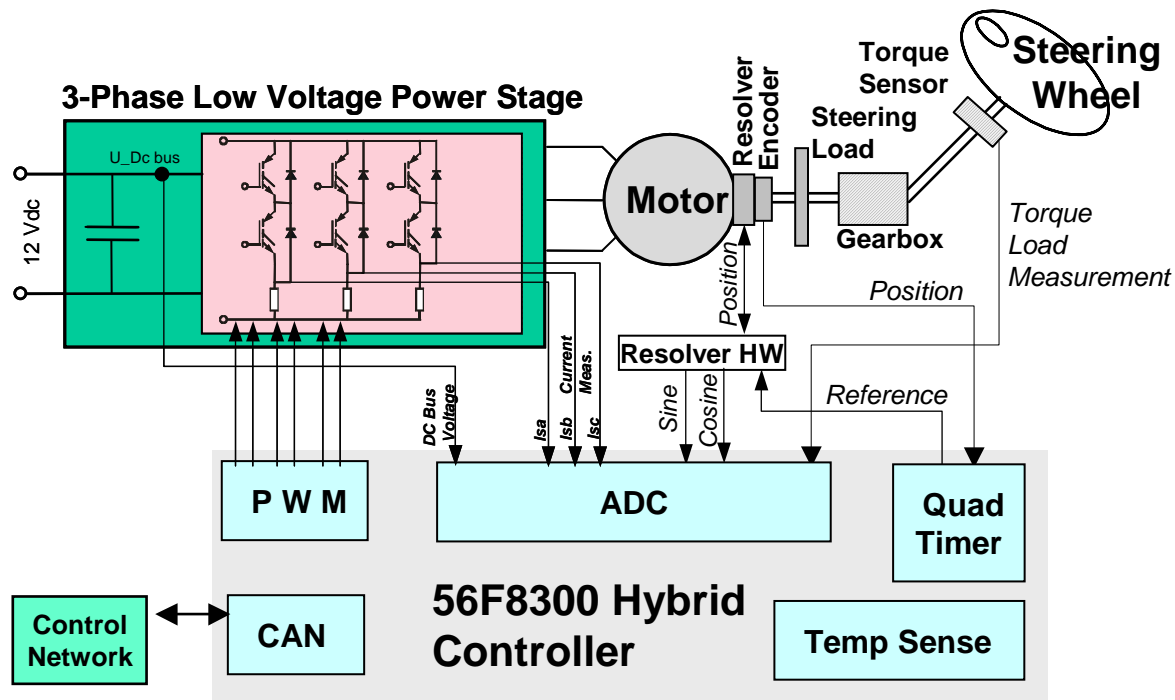

Figure 2-4. Digital Electric Power-Assisted Steering

Figure 2-5 shows an example of the software block diagram for the steering system. This application exhibits the suitability and advantages of the 56F8300 family for torque control applications using a 3-phase PMSM motor with an encoder and resolver position sensor. The application utilizes a vector control approach of the 3-phase Permanent Magnet Synchronous Motor (PMSM).

The system in this example is applicable directly to all types of automobiles. The automotive industry is aggressively developing and fielding EPAS systems and the 56F8300 device is the premier solution for the hybrid processing required in these systems. The EPAS system is generally applicable to a large number of applications in industrial heavy equipment, where power-assisted steering is used.

2.3.2 Digital Electro-Mechanical Brake (EMB) System

This is sometimes referred to as “brake by wire”. This type of system replaces a traditional power-assisted braking system controlled by hydraulics. **Figure 2-6** shows an EMB system applied to a four-wheeled vehicle. The system is comprised of a brake pedal unit that senses the brake pedal’s movement and position. It commands the four EMB units that are attached to each of the wheels. The EMB unit controls a motor that applies the force to the braking pads. The braking commands and status are communicated via a CAN bus.

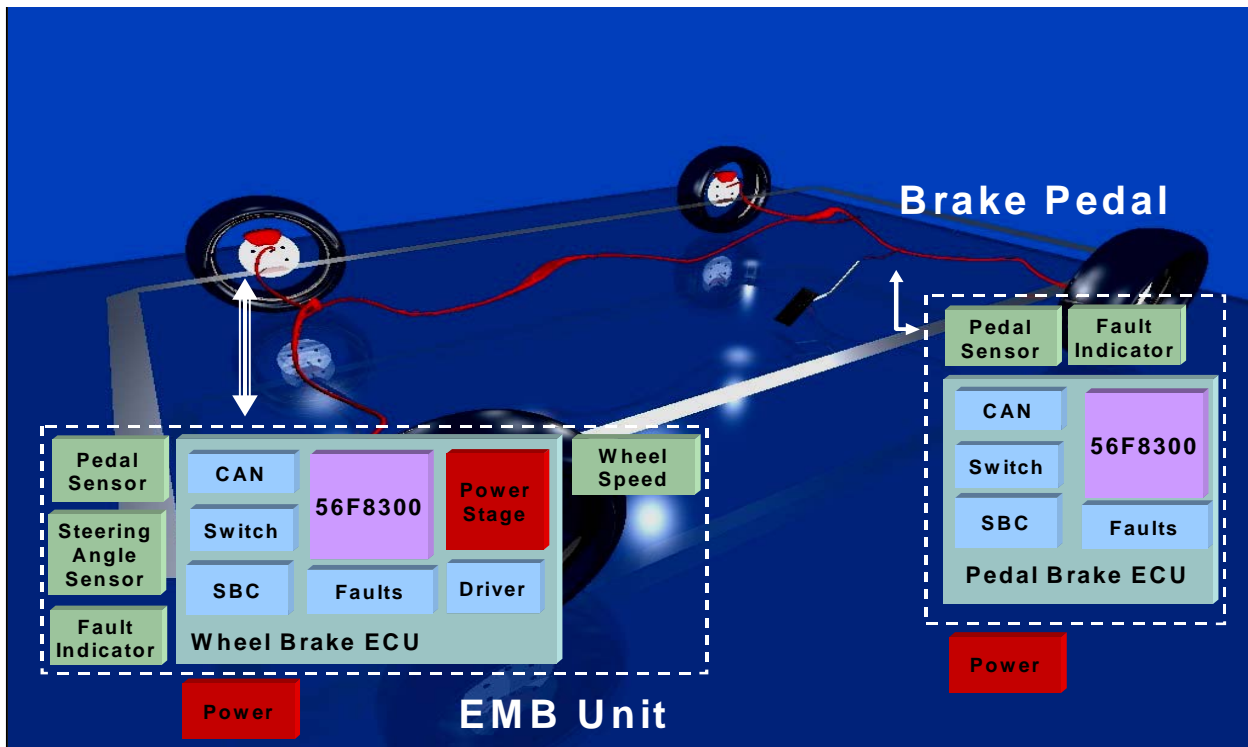

Figure 2-6. EMB System

The system shown is representative of an ordinary passenger vehicle, but can also be applied to any vehicle or industrial system that uses brakes. **Figure 2-7** shows the EMB unit as it is interfaced to the physical brake pad and rotor.

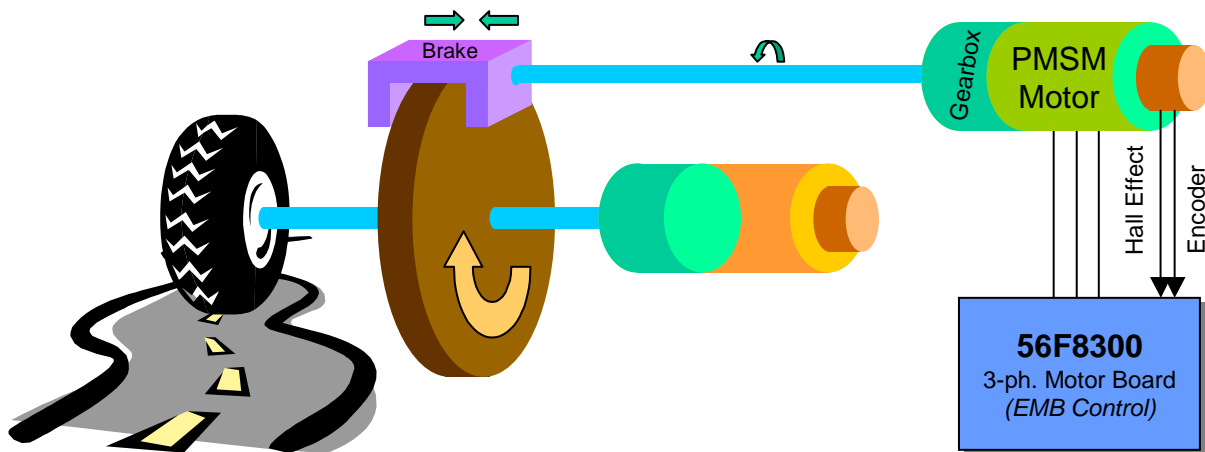

Figure 2-7. EMB Unit detail

The digital EMB system has many advantages when compared to a traditional hydraulic system. These include:

- Simpler, smaller, less-expensive system
- Improved braking performance in key areas such as distance and stability
- Intelligent system, enabling advanced traction control
- More reliable
- New networked braking features possible
- Easier support for driver/operator customization

There are a number of benefits to the EMB system as a simple replacement of the hydraulic system. A number of intelligent features are possible, since the system is processor driven. Examples are traction control and stability improvements, as each brake is controlled individually but coordinated by a central unit. In addition, since the system is networked with other components, it is now possible to receive information from many different sources and take braking action. These could be inputs from sensors attached to the vehicle which provide avoidance collision or intelligent cruise control. In addition, information could come in from sources entirely external to the vehicle, such as traffic control systems. Since the EMB is inherently an intelligent system, these features can be added without increasing the cost of the braking system itself.

2.4 Intelligent Sensor Applications

Combining today's low-cost, high-performance sensor technology with the processing capability of the 56F8300 makes traditionally high-cost intelligent sensor systems much more affordable. With the greatly reduced cost and increased performance these systems can be applied to many new markets.

One such system is the Inertial Sensor, which can be used to determine the angular and linear motion of an object. Traditionally, the inertial sensors have been used for active stabilization and navigation applications. But in the past, the intelligent inertial sensor systems were quite expensive because of the cost of mechanical accelerometers and gyros, and the cost of the high-performance processors required in the system. This made their use practical only for expensive and complex systems, such as military submarines and commercial aircraft. Now, with the introduction of low-cost MEMS sensor technology and the low-cost 56F8300 processors, much more economical inertial sensors can now be produced.

Figure 2-8 shows the degrees of freedom of a moving object that the inertial system can detect. This is an example of an inertial sensor with six degrees of freedom and a measurement of linear and angular motion on each of the three dimensional axis. Depending on the type of end system, not all variables are required.

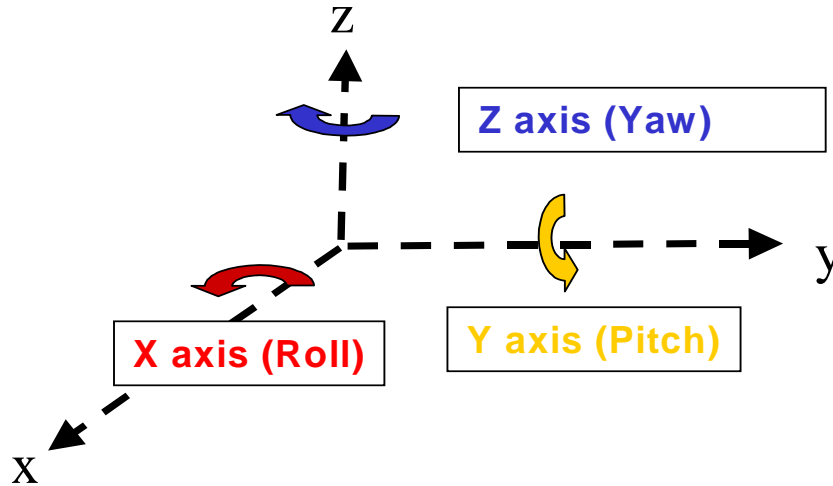

Figure 2-8. Inertial Sensor Variables

Inertial sensors find application in a broad range of end systems, such as:

- Automotive active stabilization and navigation
- Heavy equipment active stabilization and navigation
- Industrial applications such as robotics, container handling, lift systems, machine tools
- Biometric systems
- Active stabilization of camera and antennas
- Unmanned vehicles

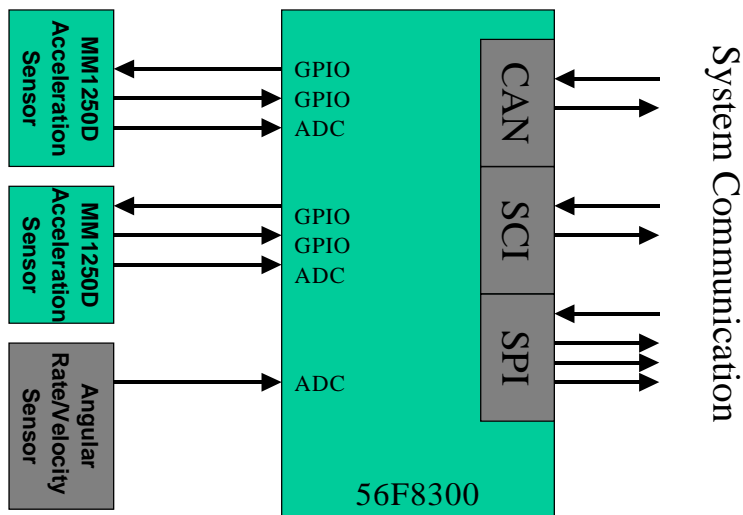

Figure 2-9. Intelligent Inertial Sensor with Three Variables

56F8300 Controller Family, Rev. 1

Figure 2-9 shows an implementation of a three-variable inertial sensor. In this example, the sensor can only detect motion in two axes and rotation on a single axis. More sensors must be added to perform all six possible variables. A three-variable inertial sensor such as this could be set up for x and y axis motion detection and z axis rotation (yaw) and could be used in a vehicle for steering/traction assistance by detecting the direction of actual vehicle movement in comparison to the desired movement. The important factors in relation to the vehicle are x and y movement and the yaw. The z axis motion is not pertinent, nor are the pitch and roll. Freescale's low G accelerometers have been used because they are well-suited for this type of application.

The cost of this inertial sensor is reduced by using the 56F8300 controller that has both the performance and integrated peripherals required by the system, and by using low-cost, high-performance MEM sensors. The unit is maintenance free and, since it is solid state, very reliable. The much-reduced price point for the end unit makes it practical for use in automotive and industrial applications.

3. Conclusions

With the introduction of the 56F8300 Series, Freescale has provided a new level of performance and integration to Flash-based products. The 56F8300 Series provides our current 8/16-bit MCU and 56F800 customers with an excellent path to increased performance and features. The enhanced performance, memory, and features of the 56F8300 Series enable a developer to expand his horizons with new product possibilities. This white paper has shown only a few of the applications made possible and practical using the new performance-leading and affordable 56F8300 Digital Signal Controllers from Freescale.

How to Reach Us:

Home Page:

www.freescale.com

E-mail:

support@freescale.com

USA/Europe or Locations Not Listed:

Freescale Semiconductor
Technical Information Center, CH370
1300 N. Alma School Road
Chandler, Arizona 85224
+1-800-521-6274 or +1-480-768-2130
support@freescale.com

Europe, Middle East, and Africa:

Freescale Halbleiter Deutschland GmbH
Technical Information Center
Schatzbogen 7
81829 Muenchen, Germany
+44 1296 380 456 (English)
+46 8 52200080 (English)
+49 89 92103 559 (German)
+33 1 69 35 48 48 (French)
support@freescale.com

Japan:

Freescale Semiconductor Japan Ltd.
Headquarters
ARCO Tower 15F
1-8-1, Shimo-Meguro, Meguro-ku,
Tokyo 153-0064, Japan
0120 191014 or +81 3 5437 9125
support.japan@freescale.com

Asia/Pacific:

Freescale Semiconductor Hong Kong Ltd.
Technical Information Center
2 Dai King Street
Tai Po Industrial Estate
Tai Po, N.T., Hong Kong
+800 2666 8080
support.asia@freescale.com

For Literature Requests Only:

Freescale Semiconductor Literature Distribution Center
P.O. Box 5405
Denver, Colorado 80217
1-800-441-2447 or 303-675-2140
Fax: 303-675-2150
LDCForFreescaleSemiconductor@hibbertgroup.com

Information in this document is provided solely to enable system and software implementers to use Freescale Semiconductor products. There are no express or implied copyright licenses granted hereunder to design or fabricate any integrated circuits or integrated circuits based on the information in this document.

Freescale Semiconductor reserves the right to make changes without further notice to any products herein. Freescale Semiconductor makes no warranty, representation or guarantee regarding the suitability of its products for any particular purpose, nor does Freescale Semiconductor assume any liability arising out of the application or use of any product or circuit, and specifically disclaims any and all liability, including without limitation consequential or incidental damages. "Typical" parameters that may be provided in Freescale Semiconductor data sheets and/or specifications can and do vary in different applications and actual performance may vary over time. All operating parameters, including "Typicals", must be validated for each customer application by customer's technical experts. Freescale Semiconductor does not convey any license under its patent rights nor the rights of others. Freescale Semiconductor products are not designed, intended, or authorized for use as components in systems intended for surgical implant into the body, or other applications intended to support or sustain life, or for any other application in which the failure of the Freescale Semiconductor product could create a situation where personal injury or death may occur. Should Buyer purchase or use Freescale Semiconductor products for any such unintended or unauthorized application, Buyer shall indemnify and hold Freescale Semiconductor and its officers, employees, subsidiaries, affiliates, and distributors harmless against all claims, costs, damages, and expenses, and reasonable attorney fees arising out of, directly or indirectly, any claim of personal injury or death associated with such unintended or unauthorized use, even if such claim alleges that Freescale Semiconductor was negligent regarding the design or manufacture of the part.



Freescale™ and the Freescale logo are trademarks of Freescale Semiconductor, Inc. All other product or service names are the property of their respective owners. This product incorporates SuperFlash® technology licensed from SST.

© Freescale Semiconductor, Inc. 2005. All rights reserved.

WP5683xx_1APPS

Rev. 1
7/2005