

MC44CM373/4

The MC44CM373/MC44CM374 CMOS family of RF modulators is the latest generation of the legacy MC44BS373/4 family of devices.

The MC44CM373/4 RF modulators are designed for use in VCRs, set-top boxes and similar devices. They support multiple standards and can be programmed to support PAL, SECAM or NTSC formats.

The devices are programmed by a high-speed I²C bus. The MC44CM373/374 family is backward compatible with the previous I²C control software, providing a smooth transition for system upgrades.

A programmable, internal Phase-Lock Loop (PLL), with an on-chip, cost-effective tank covers the full UHF range. The modulators incorporate a programmable, on-chip, sound subcarrier oscillator that covers all broadcast standards. No external tank circuit components are required, reducing PCB complexity and the need for external adjustments. The PLL obtains its reference from a cost-effective 4 MHz crystal oscillator.

The devices are available in a 16-pin SOIC, Pb-free package. These parts are functionally equivalent to the MC44BS373/4 series, but are not direct drop-in replacements.

All devices now include the aux input found previously only on the 20-pin package option. This is a direct input for a modulated subcarrier and is useful in BTSC or NICAM stereo sound or other subcarrier applications.

The MC44CM373CASEF has a secondary I²C address for applications using two modulators on one I²C Bus.

Functional Block Diagram

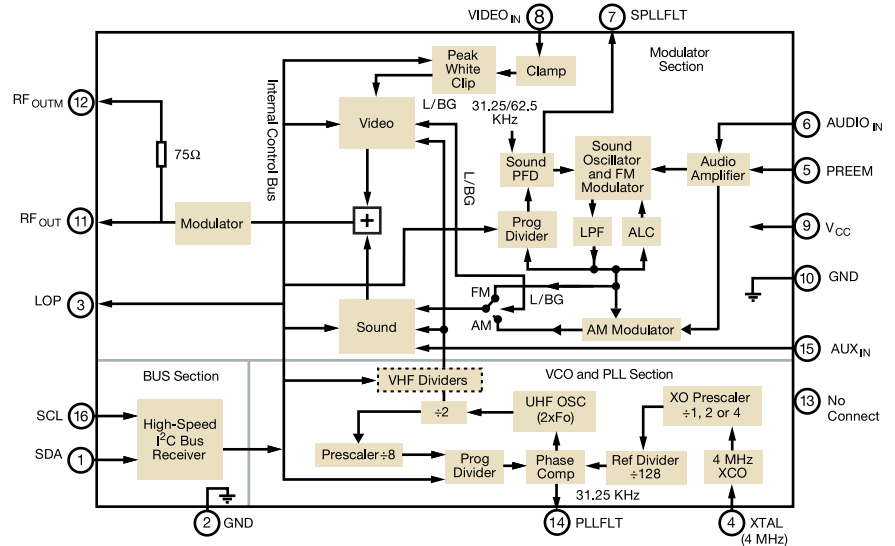

Orderable Part Numbers

New Part Number	Replaces
MC44CM373CAEF	MC44BS373CAD
	MC44BS373CAEF
	MC44BS373CAFC
MC44CM373CASEF (secondary I ² C address)	MC44BS373CAFC
MC44CM374CAEF	MC44BS374CAD
	MC44BS374CAEF
MC44CM374T1AEF	MC44BS374T1D
	MC44BS374T1EF
	MC44BS374T1AD
	MC44BS374T1AEF

Typical Applications

The MC44CM373 and MC44CM374 RF modulators are intended for applications within IP/DSL, digital terrestrial, satellite or cable set-top boxes, VCRs and DVD players or recorders, game consoles or audio/video redistribution.

Features

- Multi-standard support: NTSC, PAL, SECAM (B/G, I, D/K, L, M/N)
- UHF operation (460 MHz–880 MHz)
- On-chip tank circuits—no external varicaps, inductors or tuned components required
- Program control via 800 kHz high-speed I²C bus
- Programmable picture/sound carrier ratio (12 dB or 16 dB)
- Programmable sound reference frequency (31.25 kHz or 61.25 kHz)
- Direct sound modulator input (FM and AM)
- Auxiliary input bypassing AM/FM modulators for NICAM or BTSC applications
- Video modulation depth (93 percent typical in system L and 87.5 percent typical in the other standards)
- Programmable peak white clip

- On-chip video test pattern generator with sound test signal (1 kHz)
- Low-power standby mode
- Output inhibit during PLL lock-up at power on
- Logical output port controlled by I²C bus

Benefits

- CMOS process technology
- Functional equivalent to industry standard devices
- Backward compatibility to existing programming software
- Simplified printed circuit board layout and manufacturing (no tuned components, fewer critical RF paths)
- Reduced board space and component count
- Reduced spurious RF emission
- Shorter time to market
- Simplified sourcing (no special components)

Parameter	Typical	Units
Supply current @ 3.3V	80	mA
RF output level	82*	dBμV
UHF oscillator frequency	460 to 880	MHz
RF output attenuation	60	dBc
Sound subcarrier harmonics (F _p + n * F _s)	-63	dBc
Out band (UHF picture carrier) spurious (F _o = 460 MHz–860 MHz)	10	dBμV
In band spurious (F _o @ 5 MHz)	-65	dBc
Video bandwidth	0.5	dB
Video input level	1.0	Vcvbs
White peak clip	114	%
Video S/N	58	dB
Differential phase	-0.5	deg
Differential gain	±5	%
Luma/sync ratio	7.0/2.8	-
PAL video modulation depth	81	%
SECAM video modulation depth	93	%
Picture-to-sound ratio	12 or 16	dB
Audio modulation depth	80	%
Audio input resistance	>20	kΩ
Audio frequency response	-2.0/+2.5	dB
Audio distortion FM (THD only)	0.4	%
Audio distortion AM (THD only)	1.5	%
Audio S/N with sync buzz FM	65	dB
Audio S/N with sync buzz AM	50	dB

*Refer to AN3554 to obtain 82 dbuV or other RF levels.

Parametrics

- Power supply: 3.3 ± 10 percent V_{dc}
- Typical power consumption: 200 mW
- Temperature range, ambient: 0° to +70°C

Package

The MC44CM373 and MC44CM374 devices are offered in an industry-standard 16-pin SOIC RoHS-compliant package.

Learn More:

For current information about Freescale products and documentation, please visit www.freescale.com.