



### INTERNAL BLOCK DIAGRAM

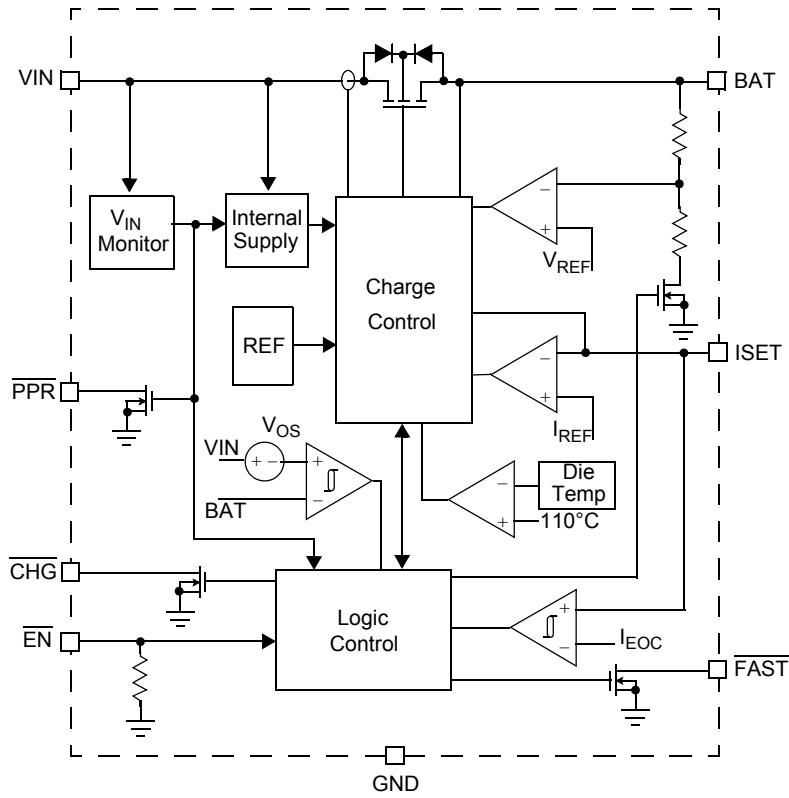

Figure 2. 34673 Simplified Internal Block Diagram

## PIN CONNECTIONS

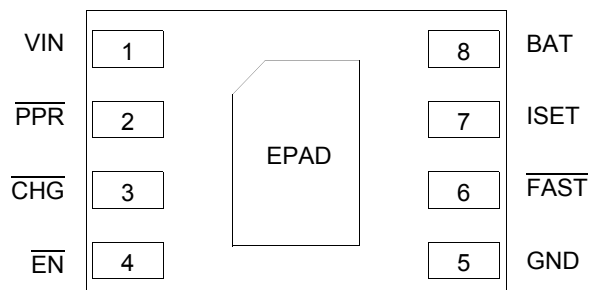

Figure 3. 34673 Pin Connections

Table 1. 34673 Pin Definitions

A functional description of each pin can be found in the Functional Pin Description section beginning on [page 11](#).

Pin Number	Pin Name	Pin Function	Formal Name	Definition
1	VIN	Input	Input supply	The supply input.
2	PPR	Output	Power present indicator	Indication of the input power status. Open drain output.
3	CHG	Output	Charge indicator	Indication of the charge status. Open drain output.
4	EN	Input	Enable	Enable logic input.
5	GND	Ground	Ground	Ground.
6	FAST	Output	Fast charge indicator	Indication of the fast charge status. Open drain output.
7	ISET	Output	CC-mode current setting and charge current monitor	CC-mode current setting and monitoring pin.
8	BAT	Output	Charger output	The charger output pin. Connect this pin to the Li-Ion battery.
EPAD	EPAD	N/A	Exposed pad	Exposed pad for thermal dissipation enhancement. Must be soldered on the large ground plane on the PCB to increase the thermal dissipation. The pad must be connected to GND electrically.

## ELECTRICAL CHARACTERISTICS

### MAXIMUM RATINGS

**Table 2. Maximum Ratings**

All voltages are with respect to ground unless otherwise noted. Exceeding these ratings may cause a malfunction or permanent damage to the device.

Ratings	Symbol	Value	Unit
<b>ELECTRICAL RATINGS</b>			
Input Voltage Range VIN Pin PPR and CHG Pins EN, BAT, ISET, and FAST Pins	V <sub>IN</sub> V <sub>PPR</sub> , V <sub>CHG</sub> V <sub>EN</sub> , V <sub>BAT</sub> , V <sub>ISET</sub> , V <sub>FAST</sub>	-0.3 to 28 -0.3 to 12 -0.3 to 5.5	V
ESD Voltage <sup>(1)</sup> Human Body Model (HBM) Machine Model (MM)	V <sub>ESD</sub>	±2000 ±200	V
<b>THERMAL RATINGS</b>			
Operating Temperature Ambient Junction	T <sub>A</sub> T <sub>J</sub>	-40 to 85 -40 to 150	°C
Storage Temperature	T <sub>STG</sub>	-65 to +150	°C
Thermal Resistance <sup>(2)</sup> Junction-to-Case Junction-to-Ambient	R <sub>θJC</sub> R <sub>θJA</sub>	10 70	°C/W
Peak Package Reflow Temperature During Reflow <sup>(3),(4)</sup>	T <sub>PPRT</sub>	Note 4	°C

**Notes**

- ESD testing is performed in accordance with the Human Body Model (HBM) (C<sub>ZAP</sub> = 100pF, R<sub>ZAP</sub> = 1500Ω), and the Machine Model (MM) (C<sub>ZAP</sub> = 200pF, R<sub>ZAP</sub> = 0Ω).
- Device mounted on the Freescale EVB test board per JEDEC DESD51-2.
- Pin soldering temperature limit is for 10 seconds maximum duration. Not designed for immersion soldering. Exceeding these limits may cause malfunction or permanent damage to the device.
- Freescale's Package Reflow capability meets Pb-free requirements for JEDEC standard J-STD-020C. For Peak Package Reflow Temperature and Moisture Sensitivity Levels (MSL), Go to [www.freescale.com](http://www.freescale.com), search by part number [e.g. remove prefixes/suffixes and enter the core ID to view all orderable parts. (i.e. MC33xxx enter 33xxx), and review parametrics.

## STATIC ELECTRICAL CHARACTERISTICS

**Table 3. Static Electrical Characteristics**

Characteristics noted under conditions  $V_{IN} = 5.0V$ ,  $-40^{\circ}C \leq T_A \leq 85^{\circ}C$ ,  $C_{IN} = 1\mu F$ ,  $C_{OUT} = 2.2\mu F$  (see [Figure 1](#)), unless otherwise noted. Typical values noted reflect the approximate parameter means at  $V_{IN} = 5.0V$  and  $T_A = 25^{\circ}C$  under nominal conditions, unless otherwise noted.

Characteristic	Symbol	Min	Typ	Max	Unit
<b>POWER INPUT</b>					
Input Voltage Range <sup>(5)</sup>	$V_{IN}$	2.6	-	6.6	V
VIN Pin Supply Current	$I_{IN}$				$\mu A$
Charger enabled <sup>(6)</sup>		-	1400	-	
Charger disabled		-	-	350	
Regulated Output Voltage	$V_{BAT}$				V
$V_{IN} = 5.0V$ ; $I_{BAT} = 10mA$ ; $T_A = 25^{\circ}C$		4.185	4.20	4.215	
$V_{IN} = 5.0V$ ; $I_{BAT} = 10mA$ ; $T_A = -20$ to $70^{\circ}C$		4.170	4.20	4.230	
$V_{IN} = 5.0V$ ; $I_{BAT} = 10mA$ ; $T_A = -40$ to $85^{\circ}C$		4.158	4.20	4.230	
Power MOSFET On Resistance	$R_{DS(ON)}$				$m\Omega$
$V_{BAT} = 4.0V$ ; $I_{BAT} = 500mA$ ; $I_{CHG} = 600mA$		-	330	475	
BAT Pin Standby Current	$I_{STDBY}$				$\mu A$
VIN not powered or charger disabled		-	-	1.0	
Power On Reset	$V_{POR}$				V
Rising $V_{IN}$ threshold		3.0	-	3.9	
Falling $V_{IN}$ threshold		-	2.4	2.6	
VIN-BAT Offset Voltage	$V_{OS}$				mV
Rising threshold		-	-	60	
Falling threshold		1.0	-	22	
Over-voltage Protection Rising Threshold	$V_{OVP}$	6.6	6.8	7.0	V
Over-voltage Protection-Threshold Hysteresis	$V_{OVPHYS}$	-	400	-	mV
<b>CHARGE CURRENT</b>					
Constant-current Mode Charge Current Range <sup>(7)</sup>	$I_{CHG}$	0.05	-	1.2	A
$I_{CHG}$ Accuracy	$I_{CHG}$				%
For $I_{CHG}$ between 300mA to 1200mA (Tested at 450mA)		94	100	106	
For $I_{CHG}$ between 50mA to 300mA <sup>(7)</sup>		90	100	110	
Trickle-Mode Charge Current	$I_{TRKL}$	16	20	24	% $I_{CHG}$
End-of-Charge (EOC) Threshold	$I_{EOC}$				mA
When $I_{CHG}$ is set to 450mA		35	45	55	
ISET Pin Voltage for $I_{CHG}$ Reference <sup>(7)</sup>	$V_{ISET}$	-	1.0	-	V

## Notes

- Refer to the Power-on-Reset parameter for  $V_{IN}$  turn on and turn off values.
- Supply current does not include the current delivered to the battery through the BAT pin.
- Not tested. Guaranteed by design.

**Table 3. Static Electrical Characteristics (continued)**

Characteristics noted under conditions  $V_{IN} = 5.0V$ ,  $-40^{\circ}C \leq T_A \leq 85^{\circ}C$ ,  $C_{IN} = 1\mu F$ ,  $C_{OUT} = 2.2\mu F$  (see [Figure 1](#)), unless otherwise noted. Typical values noted reflect the approximate parameter means at  $V_{IN} = 5.0V$  and  $T_A = 25^{\circ}C$  under nominal conditions, unless otherwise noted.

Characteristic	Symbol	Min	Typ	Max	Unit
<b>CHARGE THRESHOLDS</b>					
Trickle-Mode Rising Threshold Voltage	$V_{TRKL}$	2.6	2.7	2.8	V
Trickle-Mode Threshold Voltage Hysteresis	$V_{TRKLHYS}$	40	100	150	mV
Recharge Threshold Voltage	$V_{RECH}$	4.060	4.100	4.140	V
Recharge Falling Threshold Voltage Hysteresis	$V_{THRCHG}$	-	25	50	mV
<b>LOGIC INPUT AND OUTPUT</b>					
$\overline{EN}$ Input High Threshold Voltage	$V_{IH}$	1.5	-	-	V
$\overline{EN}$ Input Low Threshold Voltage	$V_{IL}$	-	-	0.5	V
$\overline{EN}$ Input Leakage Current $V_{\overline{EN}} = 3.0V$	$I_{\overline{EN}}$	-	2.0	7.5	$\mu A$
PPR and CHG Sink Current When the Output is Low $V_{\overline{CHG}} = V_{\overline{PPR}} = 0.6V$	$I_{PCSINKL}$	12	15	-	mA
PPR and CHG Leakage Current When the Output is High-impedance $V_{\overline{CHG}} = V_{\overline{PPR}} = 5.0V$	$I_{PCLEAKH}$	-	-	1.0	$\mu A$
FAST Sink Current When the Output is Low $V_{\overline{FAST}} = 0.5.0V$	$I_{FSINKL}$	0.3	-	-	mA
FAST Leakage Current When the Output is High-impedance $V_{\overline{FAST}} = 3.0V$	$I_{FLEAKH}$	-	-	1.0	$\mu A$
<b>CHARGE CURRENT THERMAL FOLDBACK</b>					
Current Foldback Die Temperature Limit	$T_{LIMIT}$	95	110	125	$^{\circ}C$

**DYNAMIC ELECTRICAL CHARACTERISTICS****Table 4. Dynamic Electrical Characteristics**

Characteristics noted under conditions  $V_{IN} = 5.0V$ ,  $-40^{\circ}C \leq T_A \leq 85^{\circ}C$ ,  $C_{IN} = 1\mu F$ ,  $C_{OUT} = 2.2\mu F$  ([Figure 1](#)), unless otherwise noted. Typical values noted reflect the approximate parameter means at  $V_{IN} = 5.0V$  and  $T_A = 25^{\circ}C$  under nominal conditions, unless otherwise noted.

Characteristic	Symbol	Min	Typ	Max	Unit
<b>END OF CHARGE</b>					
EOC Filter Time	$t_{EOC}$	5.5	8.0	11	ms
<b>OSCILLATOR</b>					
Oscillation Frequency	$f_{OSC}$	40.0	50.0	60.0	kHz

ELECTRICAL PERFORMANCE CURVES

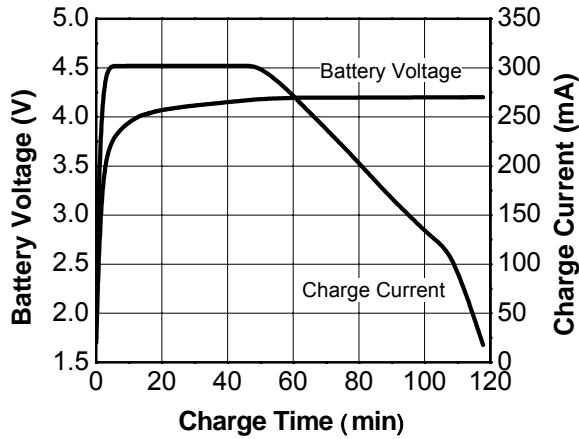

Figure 4. Complete Charge Cycle  
 $V_{IN} = 5.0V$ ,  $I_{CHG} = 300mA$ ,  $T_A = 25^\circ C$

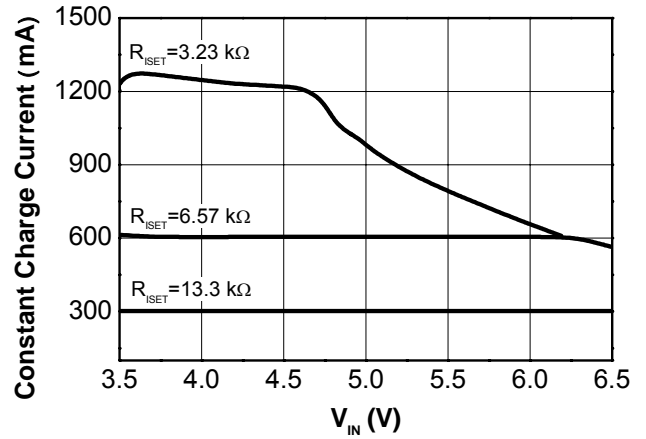

Figure 7. Constant Charge Current vs  $V_{IN}$   
 $V_{BAT} = 3.0V$ ,  $T_A = 25^\circ C$

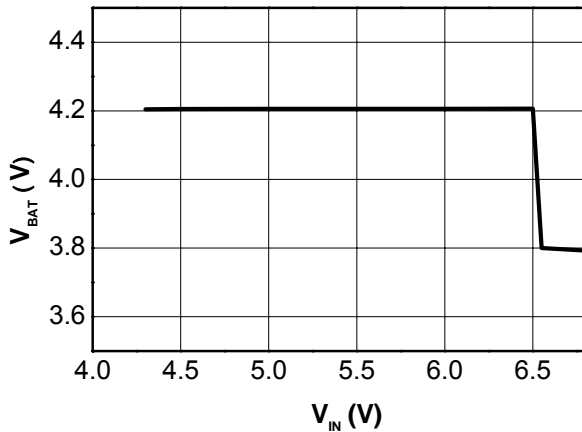

Figure 5.  $V_{BAT}$  vs  $V_{IN}$   
 $I_{BAT} = 0mA$ ,  $T_A = 25^\circ C$

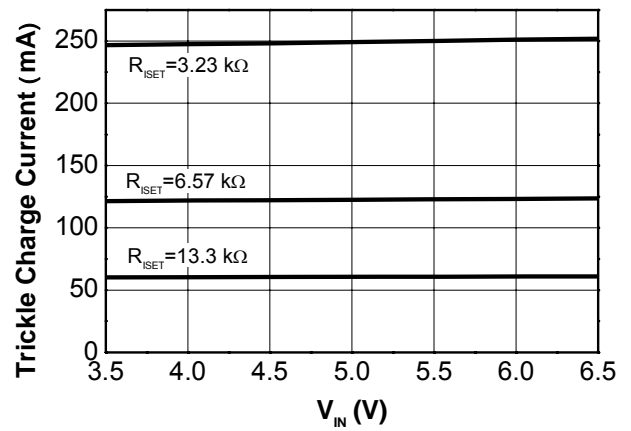

Figure 8. Trickle Charge Current vs  $V_{IN}$   
 $V_{BAT} = 2.0V$ ,  $T_A = 25^\circ C$

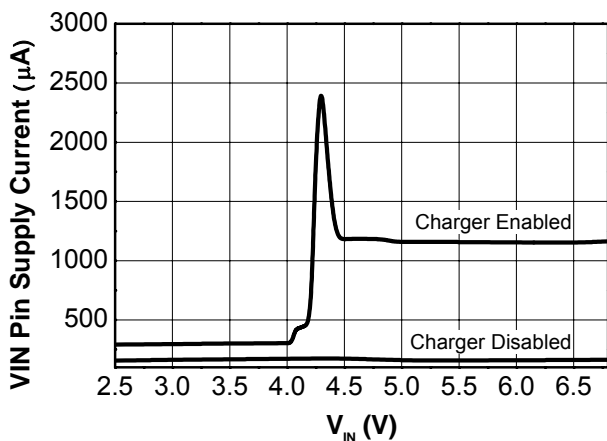

Figure 6.  $V_{IN}$  Pin Supply Current vs  $V_{IN}$   
 $I_{BAT} = 0mA$ ,  $T_A = 25^\circ C$

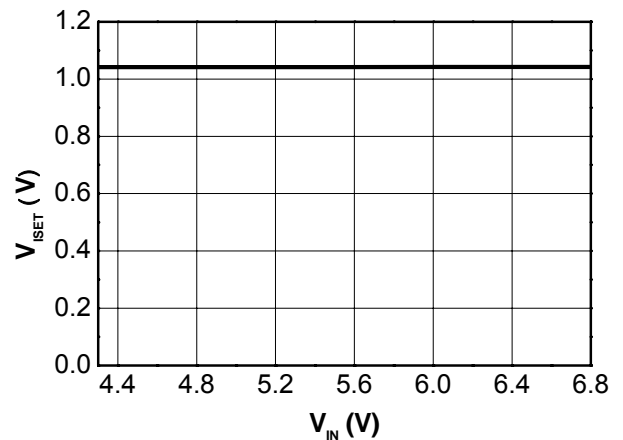

Figure 9.  $V_{ISET}$  vs  $V_{IN}$   
 $V_{BAT} = 3.9V$ ,  $T_A = 25^\circ C$

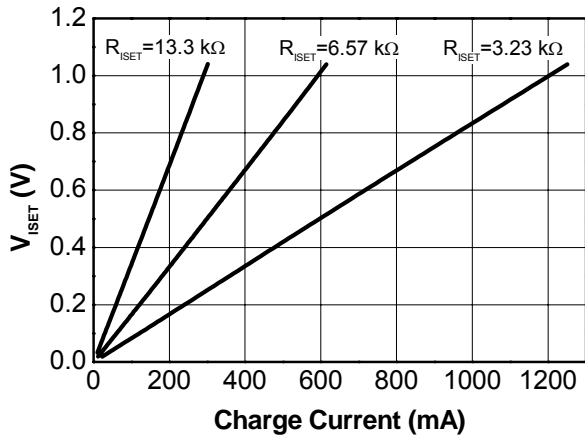

Figure 10.  $V_{ISET}$  vs Charge Current  
 $V_{IN} = 5.0V$ ,  $T_A = 25^\circ C$

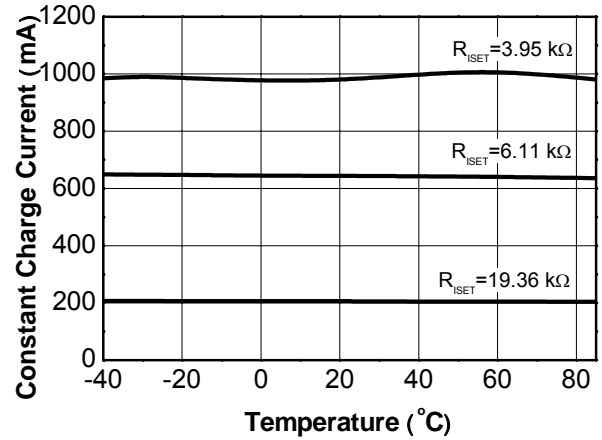

Figure 13. Constant Charge Current vs Temperature  
 $V_{IN} = 5.0V$ ,  $V_{BAT} = 3.9V$

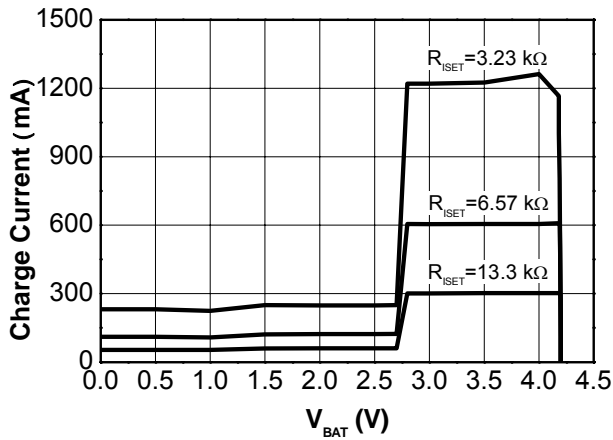

Figure 11. Charge Current vs  $V_{BAT}$   
 $V_{IN} = 5.0V$ ,  $T_A = 25^\circ C$

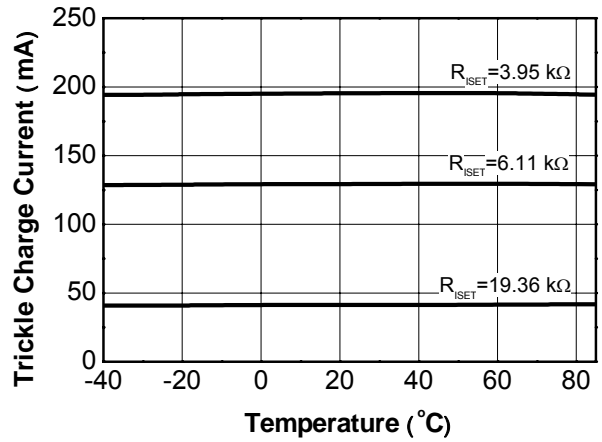

Figure 14. Trickle Charge Current vs Temperature  
 $V_{IN} = 5.0V$ ,  $V_{BAT} = 2.0V$

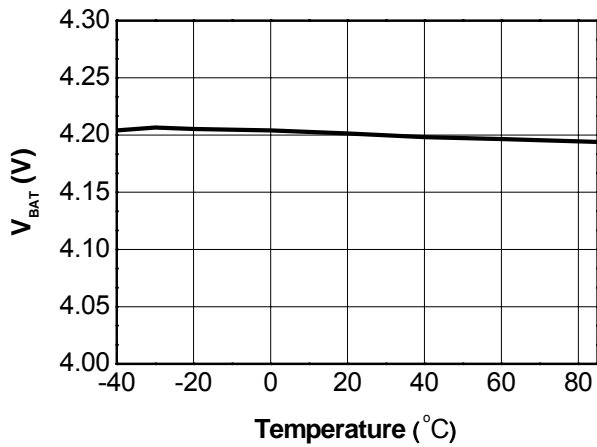

Figure 12.  $V_{BAT}$  vs Temperature  
 $V_{IN} = 5.0V$ ,  $I_{BAT} = 0mA$

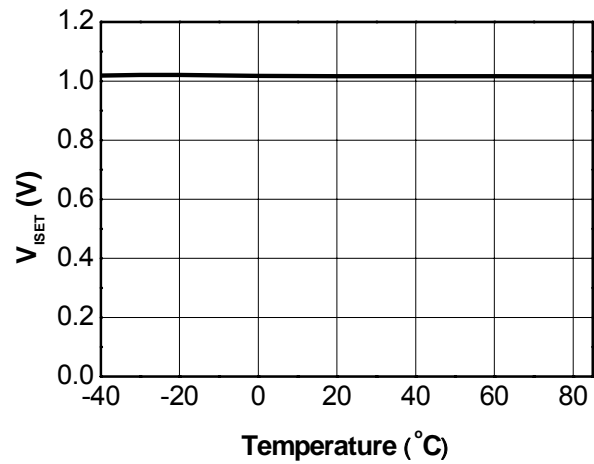

Figure 15.  $V_{ISET}$  vs Temperature  
 $V_{IN} = 5.0V$

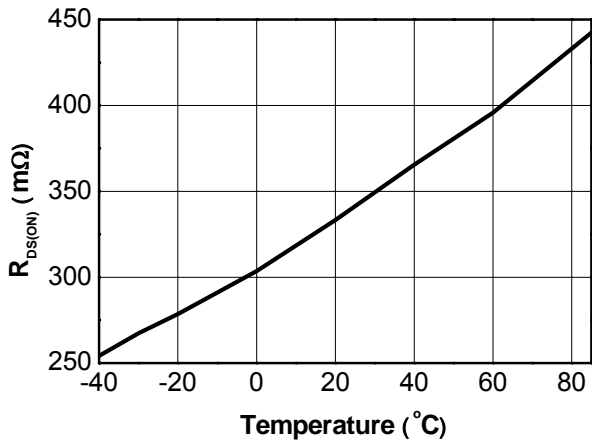

Figure 16.  $R_{DS(ON)}$  vs Temperature  
 $V_{BAT} = 4.0V$ ,  $I_{CHG} = 300mA$ ,  $I_{BAT} = 250mA$

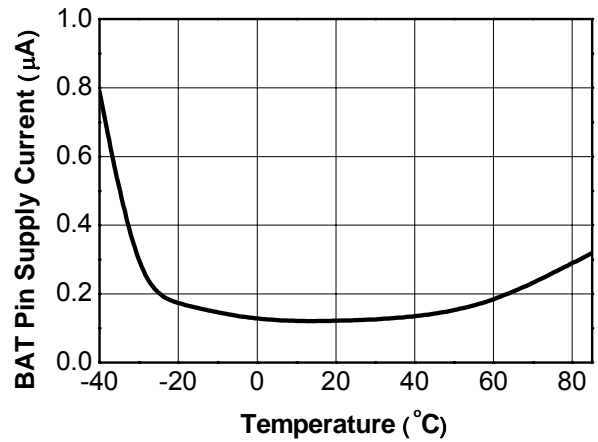

Figure 18. BAT Pin Supply Current vs Temperature  
 $V_{BAT} = 5.0V$ , VIN Not Powered or Charger Disabled

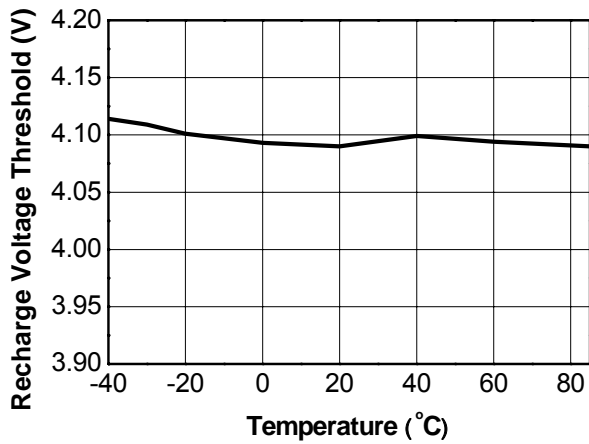

Figure 17. Recharge Voltage Threshold vs Temperature  
 $R_{ISET} = 25.86k\Omega$ ,  $V_{IN} = 5.0V$

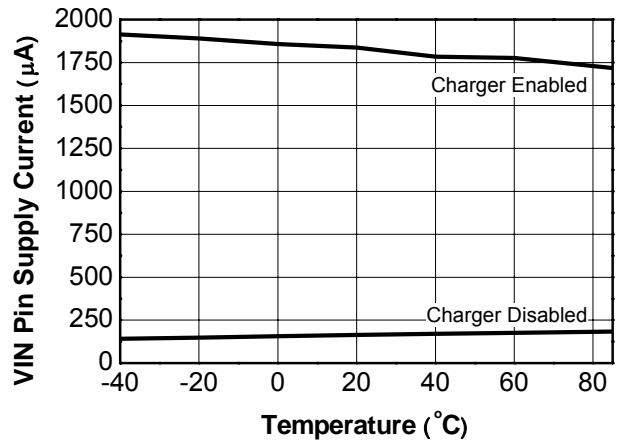

Figure 19. VIN Pin Supply Current vs Temperature  
 $V_{IN} = 5.0V$

## FUNCTIONAL DESCRIPTION

### INTRODUCTION

The MC34673 is a fully-integrated Li-Ion and Li-Polymer battery charger in a tiny package. It uses current, voltage and temperature control loops to regulate the charge current. It has up to 28V input voltage rating, which makes the handheld device safe even when connected to a wrong AC adapter.

The MC34673 requires only two external capacitors and one resistor to build a fully functional charger for space-limited applications such as PDAs, cell phones, portable video game players and digital still cameras. Its ultra high-accuracy ( $\pm 0.7\%$ ) output voltage and temperature-limited charging current offer additional battery safety during charging.

The CC-mode current can be programmed with an external resistor ( $R_{ISET}$ ). The voltage across this resistor is proportional to the charge current, so the system can monitor the charge current during the whole charge cycle. The EOC current threshold is preset to 10% of the CC-mode current. For a deeply discharged battery with a voltage lower than 2.7V, the MC34673 charges the battery with a trickle-mode current, which is 20% of the CC-mode current.

Three indication outputs make it easy to report the input power status and the charge status to MCUs, or users via LEDs.

### FUNCTIONAL PIN DESCRIPTION

#### INPUT SUPPLY ( $V_{IN}$ )

The supply input. This pin should be bypassed to ground with a 1.0 $\mu$ F capacitor.

#### POWER PRESENT INDICATOR ( $\overline{PPR}$ )

Open-drain logic output to indicate the input power status. The  $\overline{PPR}$ -pin output is only determined by the input voltage, not other conditions such as the  $\overline{EN}$  pin input. The output is low if  $V_{IN}$  is higher than  $V_{POR}$ . This pin is capable to sink at least 12.0mA current to drive a LED indicator.

#### CHARGE INDICATOR ( $\overline{CHG}$ )

Open-drain logic output to indicate the charge status. The output is low when the MC34673 is charging, until the EOC conditions are reached. This pin is capable to sink at least 12.0mA current to drive a LED indicator.

#### ENABLE ( $\overline{EN}$ )

Active-low enable logic Input. This pin is internally pulled to ground by a weak current source. When left floating, the charger is enabled. Pulling this pin to high voltage externally disables the charger.

#### GROUND (GND)

Ground.

#### FAST CHARGE INDICATOR ( $\overline{FAST}$ )

When charging, this open-drain logic output indicates whether or not the battery voltage is higher than the trickle-

mode threshold. This pin is capable to sink more than 0.3mA current. When the charger is on, this pin outputs a logic low signal if the battery voltage is higher than the trickle-mode threshold. When the charger is in the shutdown mode or in any fault conditions, this pin outputs high-impedance.

#### CC-MODE CURRENT SETTING AND CHARGE CURRENT MONITOR (ISET)

The CC-mode current,  $I_{CHG}$ , is programmed by connecting a resistor,  $R_{ISET}$ , between this pin and the ground. When charging in the CC-mode, the voltage at this pin is 1.0V. The voltage reduces proportionally as the charge current reduces in the CV-mode. During the whole charge cycle, the voltage at this pin can be used to monitor the charge current using the following equation:

$$I_{BAT} = \frac{V_{ISET}}{1.0V} \cdot I_{CHG} \quad \text{equ. 1}$$

where  $I_{BAT}$  is the actual charge current,  $I_{CHG}$  is the programmed CC-mode current, and  $V_{ISET}$  is the voltage of the ISET pin during the whole charge cycle.

#### CHARGER OUTPUT (BAT)

Charger output pin. Connect this pin to the battery being charged. Bypass to ground with a 2.2 $\mu$ F or higher capacitor.

#### EXPOSED PAD (EPAD)

Exposed pad. Must be soldered on the large ground plane on the PCB to enhance the thermal conductivity. The pad must be connected to GND electrically.

**FUNCTIONAL INTERNAL BLOCK DESCRIPTION**

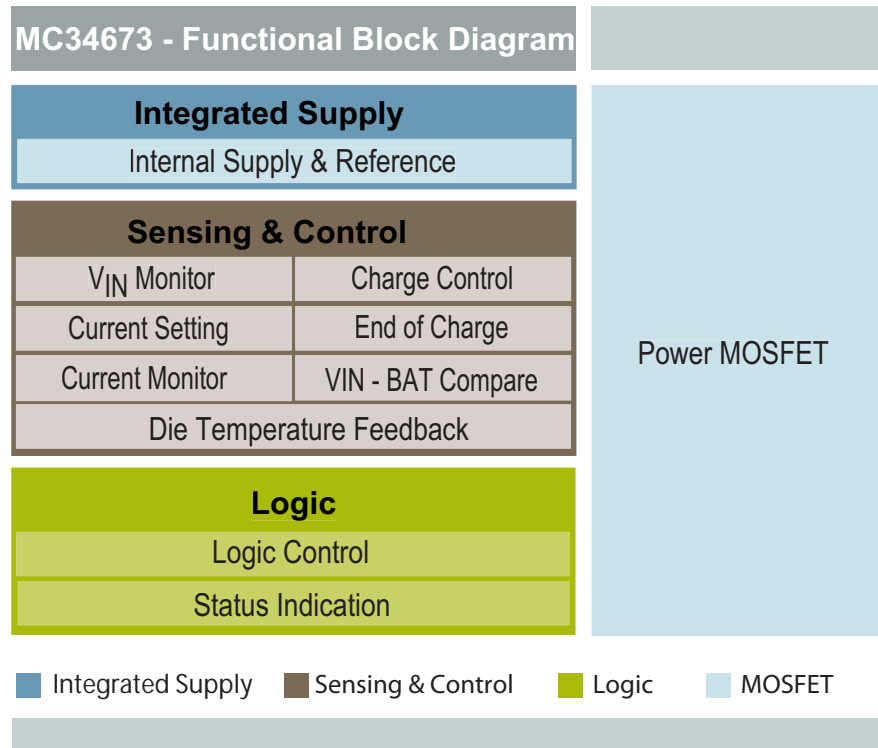

**Figure 20. 34673 Functional Internal Block Diagram**

**INTEGRATED SUPPLY**

**INTERNAL SUPPLY AND REFERENCE**

This block steps down the high input voltage to a lower voltage to power all the internal blocks. In addition, this block generates the reference voltage for the charge-control block.

**SENSING AND CONTROL**

**$V_{IN}$  MONITOR**

The input voltage monitor block monitors the input voltage for two thresholds, power-on-reset (POR) and over-voltage protection (OVP). If the input is lower than the POR or higher than the OVP threshold, this block outputs a logic signal to disable the charger.

**CHARGE CONTROL**

The charge-control block controls the gate voltage of the power MOSFET to regulate the charge current, the battery voltage, or the die temperature. It can also completely turn off the power MOSFET to stop the current flow between the input and the battery. Also, monitoring of the charge current and the charger output voltage determines the trickle-charge mode and the recharge cycle.

**CURRENT SETTING AND MONITOR**

This block programs the charge current in the constant-current mode and monitors the actual charge current during the whole charge cycle.

**EOC (END OF CHARGE)**

The EOC block monitors the charge current and the battery voltage for the EOC conditions. Once the EOC conditions are reached, this block outputs a logic signal to indicate the end of the charge.

**VIN-BAT COMPARATOR**

The VIN-BAT comparator monitors the voltage difference between the input voltage and the battery voltage. The input voltage has to be higher than the battery voltage for the charger to be enabled. If the input voltage falls below the battery voltage, this block outputs a signal to disable the charger to prevent the leakage current from the battery to the input.

**DIE TEMPERATURE FEEDBACK**

The die temperature feedback block monitors the die temperature. Once the die temperature reaches the threshold temperature, the charge-control block can reduce the charge current to prevent further die temperature rise.

## **LOGIC**

### **LOGIC CONTROL AND STATUS INDICATION**

The logic control block determines the on and off of the charger. It takes the signals from the VIN Monitor, VIN-BAT Comparator, EOC, and the external enable signal, and

determines the on and off states as well as the charge status indication outputs of the charger ( $\overline{\text{CHG}}$ ,  $\overline{\text{PPR}}$ , and  $\overline{\text{FAST}}$ ).

### **POWER MOSFET**

The power MOSFET passes the charging current from the input to the output.

## FUNCTIONAL DEVICE OPERATION

### OPERATIONAL MODES

#### CHARGE CYCLE

The MC34673 uses the standard charge profile with trickle, constant-current (CC), and constant-voltage (CV) charge modes, as shown in [Figure 21](#). Both the CC and the CV charge modes are also called fast-charge mode. When the input voltage rises above an internal power-on-reset threshold, the  $\overline{\text{PPR}}$  pin outputs a low voltage to indicate the power-supply presence. The charger starts with the trickle-charge mode until the battery voltage is above 2.7V. The  $\overline{\text{CHG}}$  pin outputs logic low voltage at the beginning of the trickle-charge mode. If the battery voltage is unable to rise due to a battery failure, charging will remain in the trickle-charge mode. When the battery voltage reaches the 2.7V threshold, the MC34673 softly changes to the CC-mode. The soft transition minimizes the input-voltage drop and reduces the requirement of the input decoupling capacitance. In the fast-charge mode, the  $\overline{\text{FAST}}$  pin outputs a low voltage. When the battery voltage reaches 4.2V, the MC34673 enters the CV-mode and regulates the output voltage at 4.2V. The charge current decreases gradually in the CV-mode. When the current drops to the EOC current threshold, the MC34673

outputs logic high voltage at the  $\overline{\text{CHG}}$  pin to indicate that the charging is completed.

After the charging is completed, the MC34673 continues to regulate the output to 4.2V, and monitors the output voltage. If a load is in parallel with the battery, the charger continues to output the current to the load even the charge is completed. If the load current exceeds the programmed CC-mode current, the battery will supply the additional current to the load and the battery voltage will decline. Once the battery voltage drops below the recharge voltage threshold, the MC34673 returns to the fast-charge mode and indicates a low voltage at the  $\overline{\text{CHG}}$  pin.

When one of the following three conditions happens, the MC34673 is disabled.

1.  $V_{\text{IN}} > V_{\text{OVP}}$
2.  $V_{\text{IN}} - V_{\text{BAT}} < V_{\text{OS}}$
3.  $\overline{\text{EN}}$  pin is high

where  $V_{\text{OS}}$  is the offset voltage for the comparator that monitors the input and the battery voltages.

[Figure 22](#) shows the complete charge-cycle state diagram.

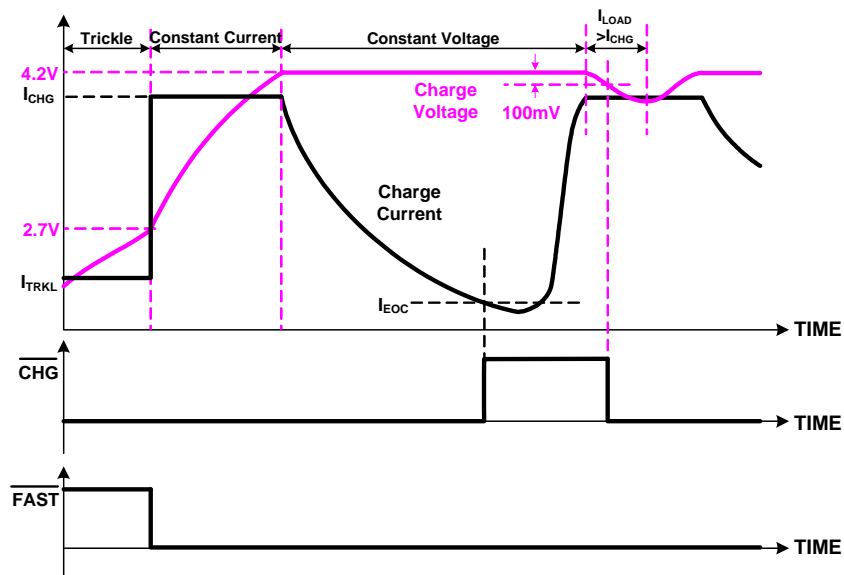

Figure 21. Charge Profile

#### CHARGE CURRENT SETTING

An external resistor between the ISET pin and the ground programmes the CC-mode current with the following equation:

$$I_{\text{CHG}} = \frac{4000}{R_{\text{ISET}} + 96} \quad \text{equ. 2}$$

where  $R_{\text{ISET}}$  is the resistor between the ISET pin and the ground in  $\Omega$ . In addition, the current out of the ISET pin is proportional to the charge current. The system may measure

the ISET pin voltage to monitor the actual charge current as given in [equ. 1](#) during the whole charging cycle.

### CHARGE CURRENT LIMITATION

The charge current is limited by multiple factors.

When the voltage difference between the input and the battery ( $V_{IN} - V_{BAT}$ ) is low,  $(V_{IN} - V_{BAT}) / R_{DS(ON)}$ , where  $R_{DS(ON)}$  is the on resistance of the power MOSFET, may be less than the programmed CC-mode current  $I_{CHG}$ . The charge current is limited by  $(V_{IN} - V_{BAT}) / R_{DS(ON)}$  in this case.

When the voltage difference between the input and the battery is too high, the large power dissipation may lead to the charge-current thermal-foldback operation due to the die temperature regulation. The charge current is reduced to prevent further temperature rise (See [Charge Current Thermal Foldback](#)).

### DC INPUT VOLTAGE

The MC34673 accepts up to 28V DC input. When all of the following conditions are satisfied, the input is in a power-good range for the charger to start charging. The conditions include:

1.  $V_{IN} > V_{POR}$
2.  $V_{IN} - V_{BAT} > V_{OS}$
3.  $V_{IN} < V_{OVP}$

where  $V_{OS}$  is the offset voltage for the comparator that monitors the input and the battery voltages. The  $V_{OS}$  is for preventing the reverse leakage current from the battery when the power supply is off.  $V_{OVP}$  is the over-voltage protection threshold. When the DC input voltage is above the over-voltage protection threshold, the charger is disabled internally. The 28V input voltage rating eliminates the need of any additional input over-voltage protection circuitry.

### CHARGE-ENABLE INPUT

The charge-enable input,  $\overline{EN}$ , has a weak internal pull-down current. Driving it to a low logic voltage, leaving it floating, or shorting it to the ground will enable the charger, if the input voltage is in the power-good range. Whenever the EN pin is driven to a high logic voltage, the charger is disabled.

### INPUT POWER PRESENCE INDICATOR

When  $V_{IN}$  is applied and the voltage is above the power-on-reset voltage threshold ( $V_{POR}$ ), the  $\overline{PPR}$  pin outputs a low voltage to indicate the input power presence. The  $\overline{PPR}$  output is only controlled by the input voltage. All other functions, such as the EN pin, the over-voltage protection, and the VIN-BAT comparator, do not affect the PPR output. The PPR pin is capable to sink at least 12.0mA current when outputting a low voltage to drive an external LED.

### CHARGE STATUS INDICATORS

The MC34673 has two charge status indicators,  $\overline{CHG}$  and  $\overline{FAST}$ .  $\overline{CHG}$  outputs a low voltage when the charger is enabled and the charging is in progress. When the charge cycle completes,  $\overline{CHG}$  outputs high-impedance. If the charger is disabled or the input voltage is out of the power-good range, the  $\overline{CHG}$  pin outputs high-impedance as well. The  $\overline{CHG}$  pin has at least 12.0mA current-sinking capability to drive an external LED, same as the  $\overline{PPR}$  pin.

$\overline{FAST}$  indicates whether the MC34673 is in the fast-charge mode or not. When the charger is on and the battery voltage is higher than the trickle-mode threshold, the charger enters the fast-charge mode and  $\overline{FAST}$  outputs a low voltage. The open-drain  $\overline{FAST}$  pin requires a pull-up resistor to output the logic signal. If the charger is in the trickle-charge mode or is disabled, or when the input voltage is out of the power-good range, the  $\overline{FAST}$  pin outputs high-impedance.

### CHARGE CURRENT THERMAL FOLDBACK

An internal thermal feedback loop begins to reduce the charge current when the die temperature reaches 110°C to prevent further temperature rise. This feature protects the MC34673 from over-temperature failures and allows the user to push the limits of the power handling capability of a given circuit board without the risk of damaging the MC34673. The charge current can be programmed according to the typical (not the worst-case) ambient temperature with the assurance that the charger will automatically reduce the current in worst-case conditions.

STATE DIAGRAM

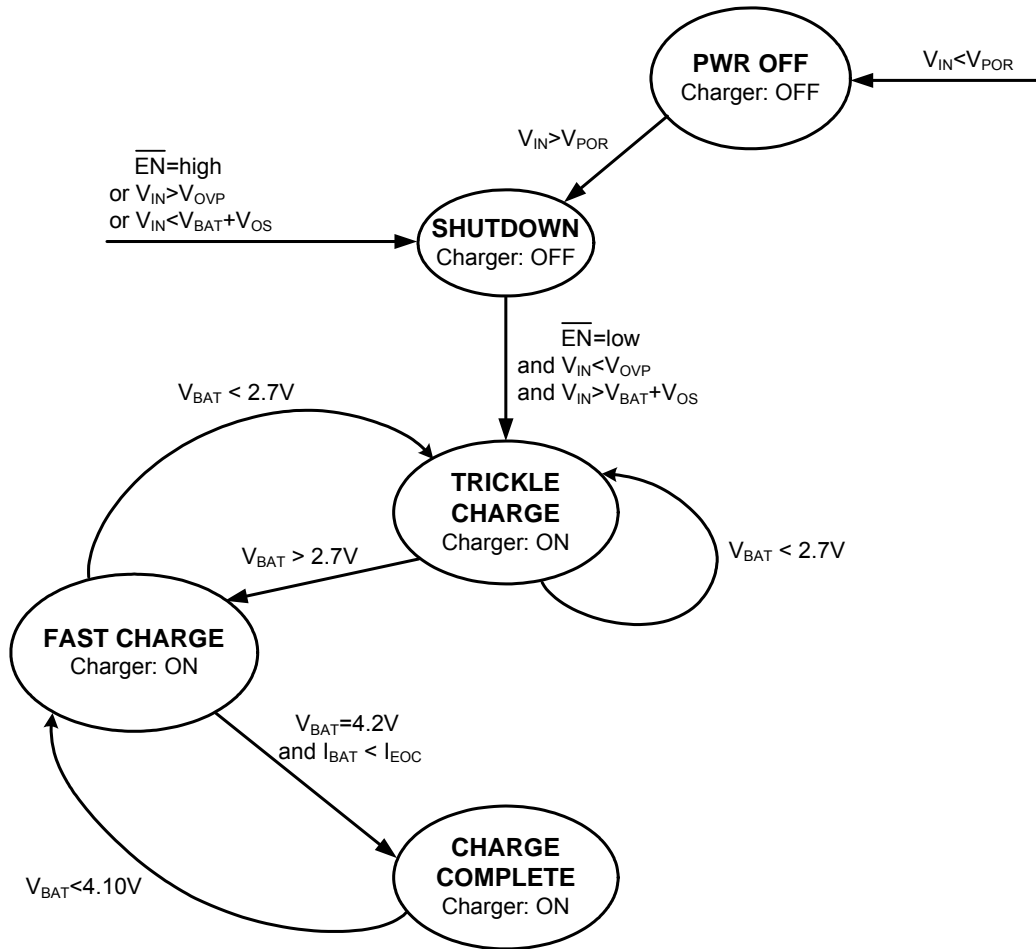

Figure 22. Charge Cycle State Diagram

## TYPICAL APPLICATIONS

## INTRODUCTION

## INPUT CAPACITOR

The input capacitor is used to reduce the input voltage transient that may cause instability. A 1.0 $\mu$ F, X5R, 16V rated ceramic capacitor is recommended for most applications.

## OUTPUT CAPACITOR

For stable operation, an X5R ceramic capacitor with a minimum 2.2 $\mu$ F nominal value is recommended at the output. Depending on the load transient current, larger capacitance may be required.

## CC-MODE CURRENT SETTING

The CC-mode current can be programmed by the external resistor,  $R_{ISET}$ . A 1% accuracy resistor is recommended to guarantee 6% current accuracy.

## DROPOUT VOLTAGE

If the DC input voltage is too low, it may not maintain the programmed CC-mode charge current due to the voltage dropout over the power MOSFET. The worst case of the  $R_{DS(ON)}$  is 475m $\Omega$ . The input voltage should be at least higher than  $V_{BAT} + I_{CHG} \times 475m\Omega$  to guarantee the programmed CC-mode current.

## THERMAL CONSIDERATIONS

The MC34673 is available in a tiny 2x3 thermally-enhanced UDFN package. A careful thermal design must be considered. The exposed pad needs to be well soldered to a large copper ground plane on the component layer. If the component layer is space limited and does not allow for a large copper plane, the thermal pad must be connected to other ground layers through a via array. This allows MC34673 to charge the battery with the maximum current, while minimizing the die temperature.

## APPLICATIONS

## STAND-ALONE CHARGER

The MC34673 can be used in a standalone charger without MCUs. [Figure 23](#) shows such an application. The

green LED indicates the power presence and the red LED indicates the charge status. In total, only 7 external components are required.

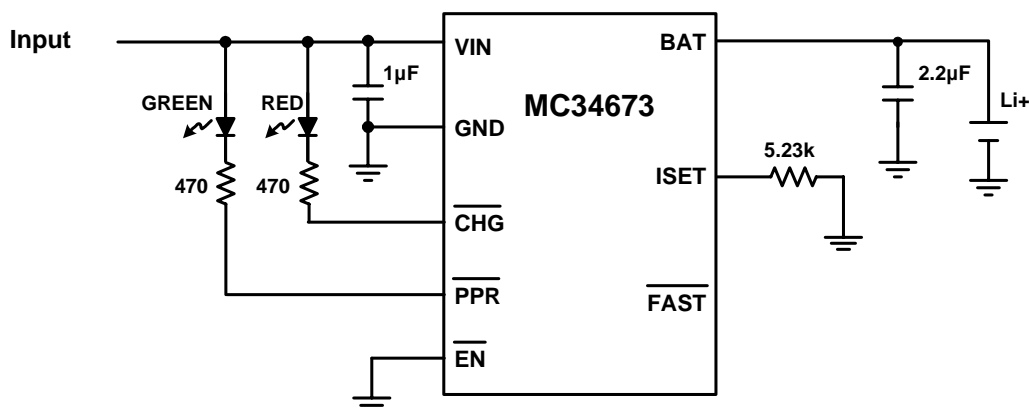

Figure 23. Stand Alone Li+ Battery Charger

### MCU INTERFACED CHARGER

When the charger is used in handheld systems with MCU control, the MC34673 uses PPR to report the DC input status to the MCU. After the MCU pulls the EN pin to a logic-low

voltage to start charging, the MC34673 reports the charge status through CHG and FAST pins to the MCU. The MCU can also monitor the charge current by measuring the voltage at the ISET pin. [Figure 24](#) is the typical application circuit.

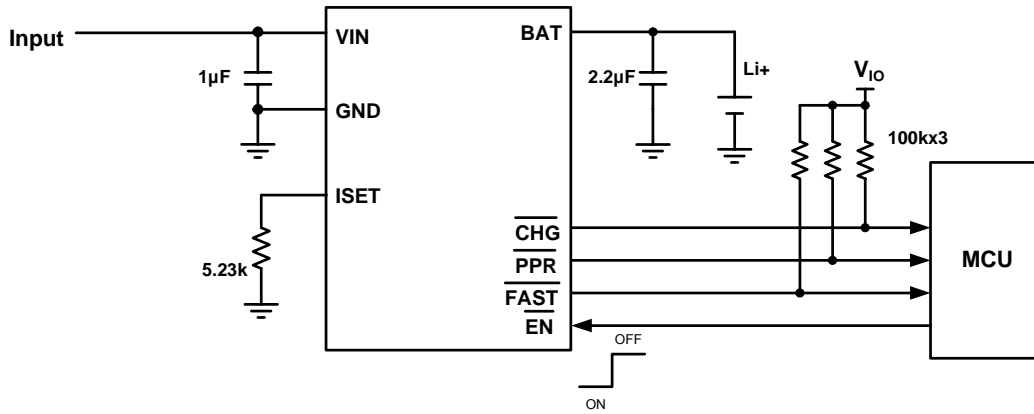
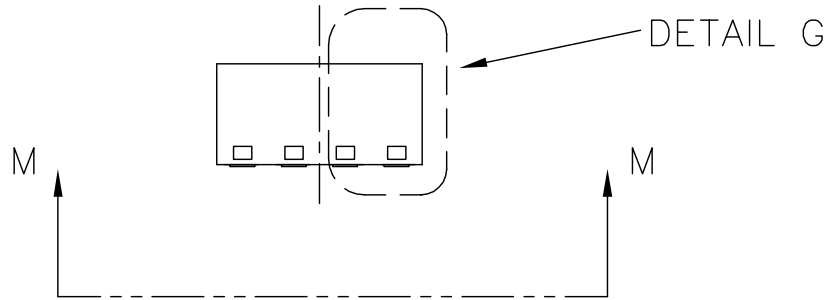
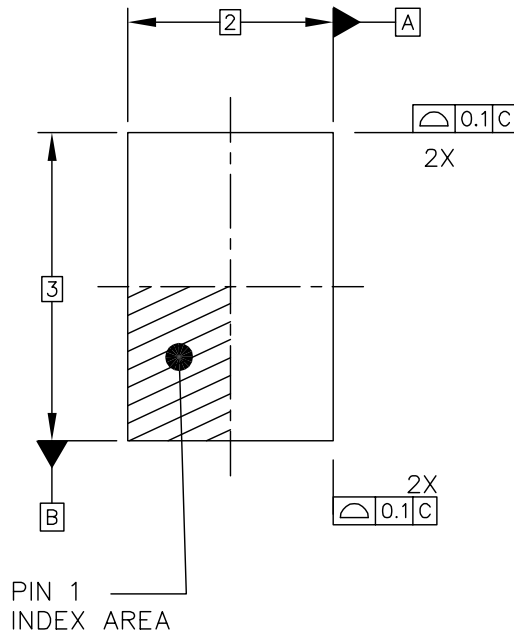

Figure 24. MCU Interfaced Charger

**PACKAGE DIMENSIONS**

For the most current package revision, visit [www.freescale.com](http://www.freescale.com) and perform a keyword search using the "98A" listed below.



© FREESCALE SEMICONDUCTOR, INC. ALL RIGHTS RESERVED.	<b>MECHANICAL OUTLINE</b>	PRINT VERSION NOT TO SCALE	
<b>TITLE:</b> THERMALLY ENHANCED PLASTIC ULTRA THIN DUAL FLAT NO LEAD PACKAGE (UDFN) 8 TERMINAL, 0.5 PITCH (2 X 3 X 0.65)	DOCUMENT NO: 98ASA10774D	REV: 0	
	CASE NUMBER: 1924-01	14 MAY 2007	
	STANDARD: NON-JEDEC		

**EP SUFFIX**  
8-PIN  
98ASA10774D  
REVISION 0

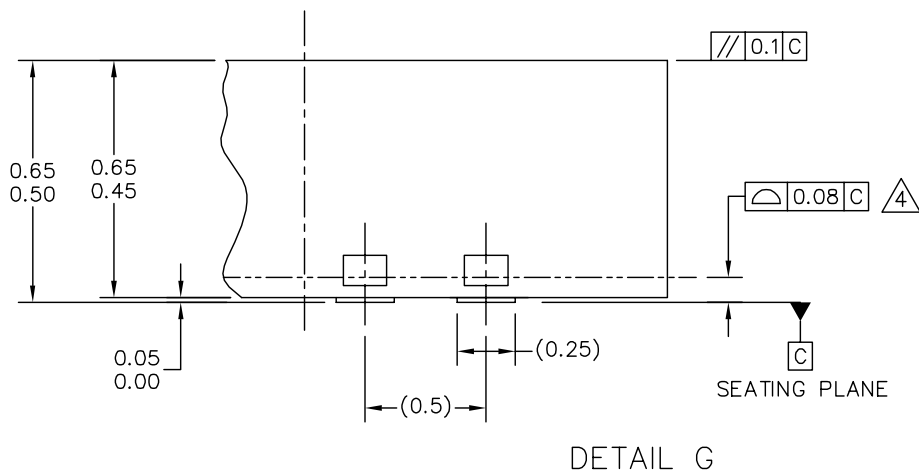
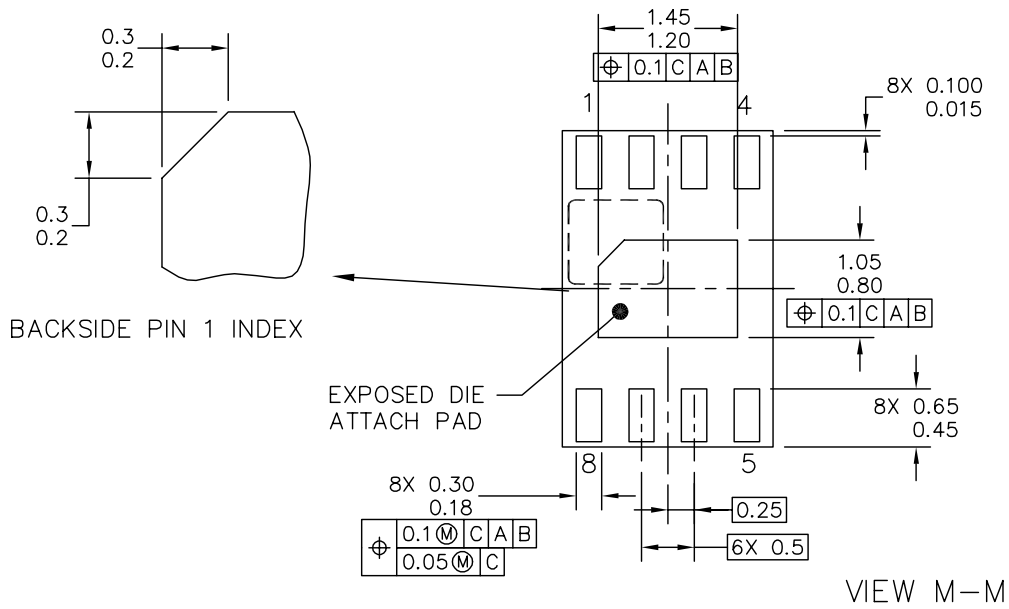

© FREESCALE SEMICONDUCTOR, INC. ALL RIGHTS RESERVED.	<b>MECHANICAL OUTLINE</b>	PRINT VERSION NOT TO SCALE	
TITLE: THERMALLY ENHANCED PLASTIC ULTRA THIN DUAL FLAT NO LEAD PACKAGE (UDFN) 8 TERMINAL, 0.5 PITCH (2 X 3 X 0.65)	DOCUMENT NO: 98ASA10774D	REV: 0	
	CASE NUMBER: 1924-01	14 MAY 2007	
	STANDARD: NON-JEDEC		

**EP SUFFIX**  
8-PIN  
98ASA10774D  
REVISION 0

## REVISION HISTORY

REVISION	DATE	DESCRIPTION OF CHANGES
1.0	1/2008	<ul style="list-style-type: none"><li>Initial Release</li></ul>

## **How to Reach Us:**

### **Home Page:**

[www.freescale.com](http://www.freescale.com)

### **Web Support:**

<http://www.freescale.com/support>

### **USA/Europe or Locations Not Listed:**

Freescale Semiconductor, Inc.  
Technical Information Center, EL516  
2100 East Elliot Road  
Tempe, Arizona 85284  
+1-800-521-6274 or +1-480-768-2130  
[www.freescale.com/support](http://www.freescale.com/support)

### **Europe, Middle East, and Africa:**

Freescale Halbleiter Deutschland GmbH  
Technical Information Center  
Schatzbogen 7  
81829 Muenchen, Germany  
+44 1296 380 456 (English)  
+46 8 52200080 (English)  
+49 89 92103 559 (German)  
+33 1 69 35 48 48 (French)  
[www.freescale.com/support](http://www.freescale.com/support)

### **Japan:**

Freescale Semiconductor Japan Ltd.  
Headquarters  
ARCO Tower 15F  
1-8-1, Shimo-Meguro, Meguro-ku,  
Tokyo 153-0064  
Japan  
0120 191014 or +81 3 5437 9125  
[support.japan@freescale.com](mailto:support.japan@freescale.com)

### **Asia/Pacific:**

Freescale Semiconductor Hong Kong Ltd.  
Technical Information Center  
2 Dai King Street  
Tai Po Industrial Estate  
Tai Po, N.T., Hong Kong  
+800 2666 8080  
[support.asia@freescale.com](mailto:support.asia@freescale.com)

### **For Literature Requests Only:**

Freescale Semiconductor Literature Distribution Center  
P.O. Box 5405  
Denver, Colorado 80217  
1-800-441-2447 or 303-675-2140  
Fax: 303-675-2150  
[LDCForFreescaleSemiconductor@hibbertgroup.com](mailto:LDCForFreescaleSemiconductor@hibbertgroup.com)

Information in this document is provided solely to enable system and software implementers to use Freescale Semiconductor products. There are no express or implied copyright licenses granted hereunder to design or fabricate any integrated circuits or integrated circuits based on the information in this document.

Freescale Semiconductor reserves the right to make changes without further notice to any products herein. Freescale Semiconductor makes no warranty, representation or guarantee regarding the suitability of its products for any particular purpose, nor does Freescale Semiconductor assume any liability arising out of the application or use of any product or circuit, and specifically disclaims any and all liability, including without limitation consequential or incidental damages. "Typical" parameters that may be provided in Freescale Semiconductor data sheets and/or specifications can and do vary in different applications and actual performance may vary over time. All operating parameters, including "Typicals", must be validated for each customer application by customer's technical experts. Freescale Semiconductor does not convey any license under its patent rights nor the rights of others. Freescale Semiconductor products are not designed, intended, or authorized for use as components in systems intended for surgical implant into the body, or other applications intended to support or sustain life, or for any other application in which the failure of the Freescale Semiconductor product could create a situation where personal injury or death may occur. Should Buyer purchase or use Freescale Semiconductor products for any such unintended or unauthorized application, Buyer shall indemnify and hold Freescale Semiconductor and its officers, employees, subsidiaries, affiliates, and distributors harmless against all claims, costs, damages, and expenses, and reasonable attorney fees arising out of, directly or indirectly, any claim of personal injury or death associated with such unintended or unauthorized use, even if such claim alleges that Freescale Semiconductor was negligent regarding the design or manufacture of the part.

Freescale™ and the Freescale logo are trademarks of Freescale Semiconductor, Inc. All other product or service names are the property of their respective owners.

© Freescale Semiconductor, Inc., 2007-8. All rights reserved.