

MCF5213 ColdFire® Integrated Microcontroller Product Brief

This document provides an overview of the major features and functional components of the MCF5213 family of microcontrollers. The MCF5213 family is a highly integrated implementation of the ColdFire® family of reduced instruction set computing (RISC) microcontrollers that also includes the MCF5211 and MCF5212. [Table 1](#) summarize the differences between these parts. This document is written from the perspective of the MCF5213.

The MCF5213 represents a family of highly-integrated 32-bit microcontrollers based on the V2 ColdFire microarchitecture. Featuring up to 32 Kbytes of internal SRAM and 256 Kbytes of flash memory, four 32-bit timers with DMA request capability, a 4-channel DMA controller, a CAN module, an I²C™ module, 3 UARTs, and a queued SPI, the MCF5213 family has been designed for general-purpose industrial control applications.

This 32-bit device is based on the Version 2 (V2) ColdFire reduced instruction set computing (RISC) core

Contents

1	MCF5213 Family Configurations	3
2	Block Diagram	3
3	Features	5
	3.1 Feature Overview	5
	3.2 Feature Details	9
4	Part Numbers and Packaging	14
5	Revision History	14

with a multiply-accumulate unit (MAC) and divider providing 76 Dhrystone 2.1 MIPS at a frequency up to 80 MHz from internal flash.

On-chip modules include:

- V2 ColdFire core with multiply-accumulate unit (MAC)
- 32 Kbytes of internal SRAM
- 256 Kbytes of on-chip flash memory
- Three universal asynchronous receiver/transmitters (UARTs)
- Controller area network 2.0B (FlexCAN) module
- Inter-integrated circuit (I²C) bus controller
- 12-bit analog-to-digital converter (ADC)
- Queued serial peripheral interface (QSPI) module
- Four-channel, 32-bit direct memory access (DMA) controller
- Four-channel, 32-bit input capture/output compare timers with optional DMA support
- Two 16-bit periodic interrupt timers (PITs)
- Programmable software watchdog timer
- Interrupt controller capable of managing up to 63 interrupt sources
- Clock module with 8 MHz on-chip relaxation oscillator and integrated phase-locked loop (PLL)

These devices are ideal for cost-sensitive applications requiring significant control processing for file management, connectivity, data buffering, and user interface, as well as signal processing in a variety of key markets such as security, imaging, networking, gaming, and medical. This leading package of integration and high performance allows fast time to market through easy code reuse and extensive third party tool support.

To locate any published errata or updates for this document, refer to the ColdFire products website at <http://www.freescale.com/coldfire>.

1 MCF5213 Family Configurations

Table 1. MCF5213 Family Configurations

Module	5211	5212	5213
ColdFire Version 2 Core with MAC (Multiply-Accumulate Unit)	•	•	•
System Clock	66 MHz	66, 80 MHz	
Performance (Dhrystone 2.1 MIPS)	63	up to 76	
Flash / Static RAM (SRAM)	128/16 Kbytes	256/32 Kbytes	
Interrupt Controller (INTC)	•	•	•
Fast Analog-to-Digital Converter (ADC)	•	•	•
FlexCAN 2.0B Module	See note ¹	•	•
Four-channel Direct-Memory Access (DMA)	•	•	•
Watchdog Timer Module (WDT)	•	•	•
Programmable Interval Timer Module (PIT)	2	2	2
Four-Channel General-Purpose Timer	3	3	3
32-bit DMA Timers	4	4	4
QSPI	•	•	•
UARTs	3	3	3
I ² C	•	•	•
PWM	8	8	8
General Purpose I/O Module (GPIO)	•	•	•
Chip Configuration and Reset Controller Module	•	•	•
Background Debug Mode (BDM)	•	•	•
JTAG - IEEE 1149.1 Test Access Port ²	•	•	•
Package	64 LQFP 64 QFN 81 MAPBGA	64 LQFP 81 MAPBGA	81 MAPBGA 100 LQFP

¹ FlexCAN is available on the MCF5211 only in the 64 QFN package.

² The full debug/trace interface is available only on the 100-pin packages. A reduced debug interface is bonded on smaller packages.

2 Block Diagram

The superset device in the MCF5213 family comes in a 100-pin leaded quad flat package (LQFP). [Figure 1](#) shows a top-level block diagram of the MCF5213.

Block Diagram

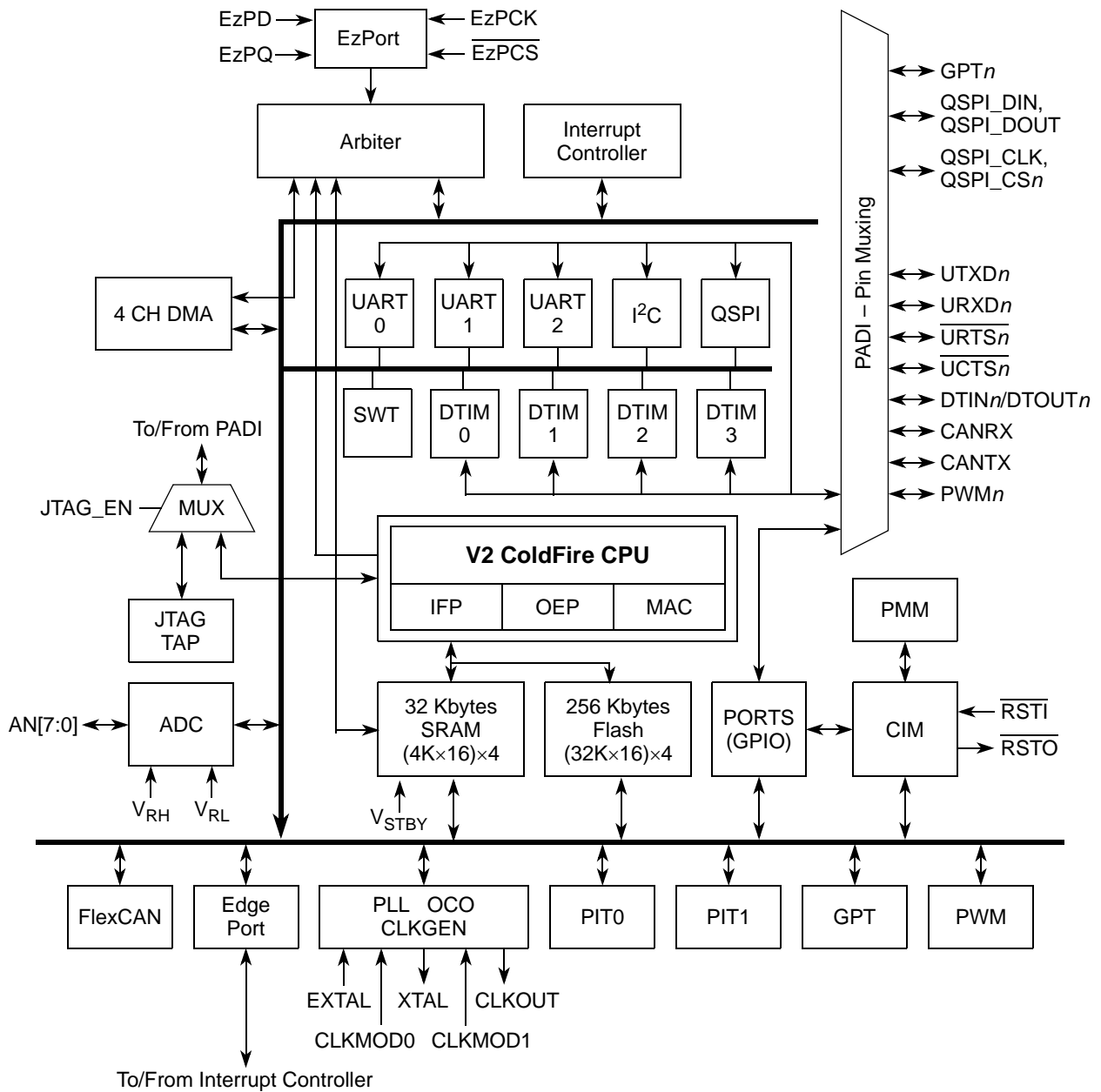

Figure 1. MCF5213 Block Diagram

3 Features

3.1 Feature Overview

The MCF5213 family includes the following features:

- Version 2 ColdFire variable-length RISC processor core
 - Static operation
 - 32-bit address and data paths on-chip
 - Up to 80 MHz processor core frequency
 - Sixteen general-purpose, 32-bit data and address registers
 - Implements ColdFire ISA_A with extensions to support the user stack pointer register and four new instructions for improved bit processing (ISA_A+)
 - Multiply-Accumulate (MAC) unit with 32-bit accumulator to support $16 \times 16 \rightarrow 32$ or $32 \times 32 \rightarrow 32$ operations
 - Illegal instruction decode that allows for 68-Kbyte emulation support
- System debug support
 - Real-time trace for determining dynamic execution path
 - Background debug mode (BDM) for in-circuit debugging (DEBUG_B+)
 - Real-time debug support, with six hardware breakpoints (4 PC, 1 address and 1 data) that can be configured into a 1- or 2-level trigger
- On-chip memories
 - 32-Kbyte dual-ported SRAM on CPU internal bus, supporting core and DMA access with standby power supply support
 - 256 Kbytes of interleaved flash memory supporting 2-1-1-1 accesses
- Power management
 - Fully static operation with processor sleep and whole chip stop modes
 - Rapid response to interrupts from the low-power sleep mode (wake-up feature)
 - Clock enable/disable for each peripheral when not used
- FlexCAN 2.0B module
 - Based on and includes all existing features of the Freescale TouCAN module
 - Full implementation of the CAN protocol specification version 2.0B
 - Standard data and remote frames (up to 109 bits long)
 - Extended data and remote frames (up to 127 bits long)
 - Zero to eight bytes data length
 - Programmable bit rate up to 1 Mbit/sec
 - Flexible message buffers (MBs), totalling up to 16 message buffers of 0–8 byte data length each, configurable as Rx or Tx, all supporting standard and extended messages

Features

- Unused MB space can be used as general purpose RAM space
- Listen-only mode capability
- Content-related addressing
- No read/write semaphores
- Three programmable mask registers: global for MBs 0-13, special for MB14, and special for MB15
- Programmable transmit-first scheme: lowest ID or lowest buffer number
- Time stamp based on 16-bit free-running timer
- Global network time, synchronized by a specific message
- Maskable interrupts
- Three universal asynchronous/synchronous receiver transmitters (UARTs)
 - 16-bit divider for clock generation
 - Interrupt control logic with maskable interrupts
 - DMA support
 - Data formats can be 5, 6, 7 or 8 bits with even, odd, or no parity
 - Up to two stop bits in 1/16 increments
 - Error-detection capabilities
 - Modem support includes request-to-send (RTS) and clear-to-send (CTS) lines for two UARTs
 - Transmit and receive FIFO buffers
- I²C module
 - Interchip bus interface for EEPROMs, LCD controllers, A/D converters, and keypads
 - Fully compatible with industry-standard I²C bus
 - Master and slave modes support multiple masters
 - Automatic interrupt generation with programmable level
- Queued serial peripheral interface (QSPI)
 - Full-duplex, three-wire synchronous transfers
 - Up to four chip selects available
 - Master mode operation only
 - Programmable bit rates up to half the CPU clock frequency
 - Up to 16 pre-programmed transfers
- Fast analog-to-digital converter (ADC)
 - Eight analog input channels
 - 12-bit resolution
 - Minimum 1.125 μ s conversion time
 - Simultaneous sampling of two channels for motor control applications

- Single-scan or continuous operation
- Optional interrupts on conversion complete, zero crossing (sign change), or under/over low/high limit
- Unused analog channels can be used as digital I/O
- Four 32-bit timers with DMA support
 - 12.5 ns resolution at 80 MHz
 - Programmable sources for clock input, including an external clock option
 - Programmable prescaler
 - Input capture capability with programmable trigger edge on input pin
 - Output compare with programmable mode for the output pin
 - Free run and restart modes
 - Maskable interrupts on input capture or output compare
 - DMA trigger capability on input capture or output compare
- Four-channel general purpose timer
 - 16-bit architecture
 - Programmable prescaler
 - Output pulse-widths variable from microseconds to seconds
 - Single 16-bit input pulse accumulator
 - Toggle-on-overflow feature for pulse-width modulator (PWM) generation
 - One dual-mode pulse accumulation channel
- Pulse-width modulation timer
 - Operates as eight channels with 8-bit resolution or four channels with 16-bit resolution
 - Programmable period and duty cycle
 - Programmable enable/disable for each channel
 - Software selectable polarity for each channel
 - Period and duty cycle are double buffered. Change takes effect when the end of the current period is reached (PWM counter reaches zero) or when the channel is disabled.
 - Programmable center or left aligned outputs on individual channels
 - Four clock sources (A, B, SA, and SB) provide for a wide range of frequencies
 - Emergency shutdown
- Two periodic interrupt timers (PITs)
 - 16-bit counter
 - Selectable as free running or count down
- Software watchdog timer
 - 32-bit counter
 - Low-power mode support

Features

- Clock generation features
 - One to 48 MHz crystal, 8 MHz on-chip relaxation oscillator, or external oscillator reference options
 - Trimmed relaxation oscillator
 - Two to 10 MHz reference frequency for normal PLL mode with a pre-divider programmable from 1 to 8
 - System can be clocked from PLL or directly from crystal oscillator or relaxation oscillator
 - Low power modes supported
 - 2^n ($n \leq 0 \leq 15$) low-power divider for extremely low frequency operation
- Interrupt controller
 - Uniquely programmable vectors for all interrupt sources
 - Fully programmable level and priority for all peripheral interrupt sources
 - Seven external interrupt signals with fixed level and priority
 - Unique vector number for each interrupt source
 - Ability to mask any individual interrupt source or all interrupt sources (global mask-all)
 - Support for hardware and software interrupt acknowledge (IACK) cycles
 - Combinatorial path to provide wake-up from low-power modes
- DMA controller
 - Four fully programmable channels
 - Dual-address transfer support with 8-, 16-, and 32-bit data capability, along with support for 16-byte (4×32-bit) burst transfers
 - Source/destination address pointers that can increment or remain constant
 - 24-bit byte transfer counter per channel
 - Auto-alignment transfers supported for efficient block movement
 - Bursting and cycle steal support
 - Software-programmable DMA requesters for the UARTs (3) and 32-bit timers (4)
- Reset
 - Separate reset in and reset out signals
 - Seven sources of reset:
 - Power-on reset (POR)
 - External
 - Software
 - Watchdog
 - Loss of clock
 - Loss of lock
 - Low-voltage detection (LVD)

- Status flag indication of source of last reset
- Chip integration module (CIM)
 - System configuration during reset
 - Selects one of six clock modes
 - Configures output pad drive strength
 - Unique part identification number and part revision number
- General purpose I/O interface
 - Up to 56 bits of general purpose I/O
 - Bit manipulation supported via set/clear functions
 - Programmable drive strengths
 - Unused peripheral pins may be used as extra GPIO
- JTAG support for system level board testing

3.2 Feature Details

3.2.1 V2 Core Overview

The version 2 ColdFire processor core is comprised of two separate pipelines decoupled by an instruction buffer. The two-stage instruction fetch pipeline (IFP) is responsible for instruction-address generation and instruction fetch. The instruction buffer is a first-in-first-out (FIFO) buffer that holds prefetched instructions awaiting execution in the operand execution pipeline (OEP). The OEP includes two pipeline stages. The first stage decodes instructions and selects operands (DSOC); the second stage (AGEX) performs instruction execution and calculates operand effective addresses, if needed.

The V2 core implements the ColdFire instruction set architecture revision A+ with added support for a separate user stack pointer register and four new instructions to assist in bit processing. Additionally, the MCF5213 core includes the multiply-accumulate (MAC) unit for improved signal processing capabilities. The MAC implements a three-stage arithmetic pipeline, optimized for 16×16 bit operations, with support for one 32-bit accumulator. Supported operands include 16- and 32-bit signed and unsigned integers, signed fractional operands, and a complete set of instructions to process these data types. The MAC provides support for execution of DSP operations within the context of a single processor at a minimal hardware cost.

3.2.2 Integrated Debug Module

The ColdFire processor core debug interface is provided to support system debugging with low-cost debug and emulator development tools. Through a standard debug interface, access to debug information and real-time tracing capability is provided on 100-lead packages. This allows the processor and system to be debugged at full speed without the need for costly in-circuit emulators.

The on-chip breakpoint resources include a total of nine programmable 32-bit registers: an address and an address mask register, a data and a data mask register, four PC registers, and one PC mask register. These registers can be accessed through the dedicated debug serial communication channel or from the

processor's supervisor mode programming model. The breakpoint registers can be configured to generate triggers by combining the address, data, and PC conditions in a variety of single- or dual-level definitions. The trigger event can be programmed to generate a processor halt or initiate a debug interrupt exception. The MCF5213 implements revision B+ of the ColdFire Debug Architecture.

The MCF5213's interrupt servicing options during emulator mode allow real-time critical interrupt service routines to be serviced while processing a debug interrupt event. This ensures the system continues to operate even during debugging.

To support program trace, the V2 debug module provides processor status (PST[3:0]) and debug data (DDATA[3:0]) ports. These buses and the PSTCLK output provide execution status, captured operand data, and branch target addresses defining processor activity at the CPU's clock rate. The MCF5213 includes a new debug signal, ALLPST. This signal is the logical AND of the processor status (PST[3:0]) signals and is useful for detecting when the processor is in a halted state (PST[3:0] = 1111).

The full debug/trace interface is available only on the 100-pin packages. However, every product features the dedicated debug serial communication channel (DSI, DSO, DSCLK) and the ALLPST signal.

3.2.3 JTAG

The MCF5213 supports circuit board test strategies based on the Test Technology Committee of IEEE and the Joint Test Action Group (JTAG). The test logic includes a test access port (TAP) consisting of a 16-state controller, an instruction register, and three test registers (a 1-bit bypass register, a 256-bit boundary-scan register, and a 32-bit ID register). The boundary scan register links the device's pins into one shift register. Test logic, implemented using static logic design, is independent of the device system logic.

The MCF5213 implementation can:

- Perform boundary-scan operations to test circuit board electrical continuity
- Sample MCF5213 system pins during operation and transparently shift out the result in the boundary scan register
- Bypass the MCF5213 for a given circuit board test by effectively reducing the boundary-scan register to a single bit
- Disable the output drive to pins during circuit-board testing
- Drive output pins to stable levels

3.2.4 On-Chip Memories

3.2.4.1 SRAM

The dual-ported SRAM module provides a general-purpose 32-Kbyte memory block that the ColdFire core can access in a single cycle. The location of the memory block can be set to any 32-Kbyte boundary within the 4-Gbyte address space. This memory is ideal for storing critical code or data structures and for use as the system stack. Because the SRAM module is physically connected to the processor's high-speed local bus, it can quickly service core-initiated accesses or memory-referencing commands from the debug module.

The SRAM module is also accessible by the DMA. The dual-ported nature of the SRAM makes it ideal for implementing applications with double-buffer schemes, where the processor and a DMA device operate in alternate regions of the SRAM to maximize system performance.

3.2.4.2 Flash Memory

The ColdFire flash module (CFM) is a non-volatile memory (NVM) module that connects to the processor's high-speed local bus. The CFM is constructed with four banks of 32-Kbyte×16-bit flash memory arrays to generate 256 Kbytes of 32-bit flash memory. These electrically erasable and programmable arrays serve as non-volatile program and data memory. The flash memory is ideal for program and data storage for single-chip applications, allowing for field reprogramming without requiring an external high voltage source. The CFM interfaces to the ColdFire core through an optimized read-only memory controller that supports interleaved accesses from the 2-cycle flash memory arrays. A backdoor mapping of the flash memory is used for all program, erase, and verify operations, as well as providing a read datapath for the DMA. Flash memory may also be programmed via the EzPort, which is a serial flash memory programming interface that allows the flash memory to be read, erased and programmed by an external controller in a format compatible with most SPI bus flash memory chips.

3.2.5 Power Management

The MCF5213 incorporates several low-power modes of operation which are entered under program control and exited by several external trigger events. An integrated power-on reset (POR) circuit monitors the input supply and forces an MCU reset as the supply voltage rises. The low voltage detector (LVD) monitors the supply voltage and is configurable to force a reset or interrupt condition if it falls below the LVD trip point. The RAM standby switch provides power to RAM when the supply voltage to the chip falls below the standby battery voltage.

3.2.6 FlexCAN

The FlexCAN module is a communication controller implementing version 2.0 of the CAN protocol parts A and B. The CAN protocol can be used as an industrial control serial data bus, meeting the specific requirements of reliable operation in a harsh EMI environment with high bandwidth. This instantiation of FlexCAN has 16 message buffers.

3.2.7 UARTs

The MCF5213 has three full-duplex UARTs that function independently. The three UARTs can be clocked by the system bus clock, eliminating the need for an external clock source. On smaller packages, the third UART is multiplexed with other digital I/O functions.

3.2.8 I²C Bus

The I²C bus is a two-wire, bidirectional serial bus that provides a simple, efficient method of data exchange and minimizes the interconnection between devices. This bus is suitable for applications requiring occasional communications over a short distance between many devices.

3.2.9 QSPI

The queued serial peripheral interface (QSPI) provides a synchronous serial peripheral interface with queued transfer capability. It allows up to 16 transfers to be queued at once, minimizing the need for CPU intervention between transfers.

3.2.10 Fast ADC

The fast ADC consists of an eight-channel input select multiplexer and two independent sample and hold (S/H) circuits feeding separate 12-bit ADCs. The two separate converters store their results in accessible buffers for further processing.

The ADC can be configured to perform a single scan and halt, a scan when triggered, or a programmed scan sequence repeatedly until manually stopped.

The ADC can be configured for sequential or simultaneous conversion. When configured for sequential conversions, up to eight channels can be sampled and stored in any order specified by the channel list register. Both ADCs may be required during a scan, depending on the inputs to be sampled.

During a simultaneous conversion, both S/H circuits are used to capture two different channels at the same time. This configuration requires that a single channel may not be sampled by both S/H circuits simultaneously.

Optional interrupts can be generated at the end of the scan sequence if a channel is out of range (measures below the low threshold limit or above the high threshold limit set in the limit registers) or at several different zero crossing conditions.

3.2.11 DMA Timers (DTIM0–DTIM3)

There are four independent, DMA transfer capable 32-bit timers (DTIM0, DTIM1, DTIM2, and DTIM3) on the MCF5213. Each module incorporates a 32-bit timer with a separate register set for configuration and control. The timers can be configured to operate from the system clock or from an external clock source using one of the DTIN n signals. If the system clock is selected, it can be divided by 16 or 1. The input clock is further divided by a user-programmable 8-bit prescaler that clocks the actual timer counter register (TCR n). Each of these timers can be configured for input capture or reference (output) compare mode. Timer events may optionally cause interrupt requests or DMA transfers.

3.2.12 General Purpose Timer (GPT)

The general purpose timer (GPT) is a four-channel timer module consisting of a 16-bit programmable counter driven by a seven-stage programmable prescaler. Each of the four channels can be configured for input capture or output compare. Additionally, one of the channels, channel three, can be configured as a pulse accumulator.

A timer overflow function allows software to extend the timing capability of the system beyond the 16-bit range of the counter. The input capture and output compare functions allow simultaneous input waveform measurements and output waveform generation. The input capture function can capture the time of a

selected transition edge. The output compare function can generate output waveforms and timer software delays. The 16-bit pulse accumulator can operate as a simple event counter or a gated time accumulator.

3.2.13 Periodic Interrupt Timers (PIT0 and PIT1)

The two periodic interrupt timers (PIT0 and PIT1) are 16-bit timers that provide interrupts at regular intervals with minimal processor intervention. Each timer can count down from the value written in its PIT modulus register or it can be a free-running down-counter.

3.2.14 Pulse-Width Modulation (PWM) Timers

The MCF5213 has an 8-channel, 8-bit PWM timer. Each channel has a programmable period and duty cycle as well as a dedicated counter. Each of the modulators can create independent continuous waveforms with software-selectable duty rates from 0% to 100%. The PWM outputs have programmable polarity, and can be programmed as left aligned outputs or center aligned outputs. For higher period and duty cycle resolution, each pair of adjacent channels ([7:6], [5:4], [3:2], and [1:0]) can be concatenated to form a single 16-bit channel. The module can, therefore, be configured to support 8/0, 6/1, 4/2, 2/3, or 0/4 8-/16-bit channels.

3.2.15 Software Watchdog Timer

The watchdog timer is a 32-bit timer that facilitates recovery from runaway code. The watchdog counter is a free-running down-counter that generates a reset on underflow. To prevent a reset, software must periodically restart the countdown.

3.2.16 Phase-Locked Loop (PLL)

The clock module contains a crystal oscillator, 8 MHz on-chip relaxation oscillator (OCO), phase-locked loop (PLL), reduced frequency divider (RFD), low-power divider status/control registers, and control logic. To improve noise immunity, the PLL, crystal oscillator, and relaxation oscillator have their own power supply inputs: VDDPLL and VSSPLL. All other circuits are powered by the normal supply pins, VDD and VSS.

3.2.17 Interrupt Controller (INTC)

The MCF5213 has a single interrupt controller that supports up to 63 interrupt sources. There are 56 programmable sources, 49 of which are assigned to unique peripheral interrupt requests. The remaining seven sources are unassigned and may be used for software interrupt requests.

3.2.18 DMA Controller

The direct memory access (DMA) controller provides an efficient way to move blocks of data with minimal processor intervention. It has four channels that allow byte, word, longword, or 16-byte burst line transfers. These transfers are triggered by software explicitly setting a $DCR_n[START]$ bit or by the occurrence of certain UART or DMA timer events.

3.2.19 Reset

The reset controller determines the source of reset, asserts the appropriate reset signals to the system, and keeps track of what caused the last reset. There are seven sources of reset:

- External reset input
- Power-on reset (POR)
- Watchdog timer
- Phase locked-loop (PLL) loss of lock
- PLL loss of clock
- Software
- Low-voltage detector (LVD)

Control of the LVD and its associated reset and interrupt are managed by the reset controller. Other registers provide status flags indicating the last source of reset and a control bit for software assertion of the RSTO pin.

3.2.20 GPIO

Nearly all pins on the MCF5213 have general purpose I/O capability and are grouped into 8-bit ports. Some ports do not use all eight bits. Each port has registers that configure, monitor, and control the port pins.

4 Part Numbers and Packaging

This product is RoHS-compliant. Refer to the product page at www.freescale.com or contact your sales office for up-to-date RoHS information.

Table 2. Part Number Summary

Part Number	Flash / SRAM	Key Features	Package	Speed
MCF5211	128 Kbytes / 16 Kbytes	3 UARTs, I ² C, QSPI, A/D, DMA, 16-/32-bit/PWM Timers	64 LQFP 81 MAPBGA 64 QFN	66 MHz 66, 80 MHz 66 MHz
MCF5212	256 Kbytes / 32 Kbytes	3 UARTs, I ² C, QSPI, A/D, DMA, 16-/32-bit/PWM Timers	64 LQFP 81 MAPBGA	66 MHz 66, 80 MHz
MCF5213	256 Kbytes / 32 Kbytes	3 UARTs, I ² C, QSPI, A/D, DMA, 16-/32-bit/PWM Timers, CAN	81 MAPBGA 100 LQFP	66, 80 MHz 66, 80 MHz

5 Revision History

Table 3 shows the revision history for this document.

Table 3. Revision History

Revision	Description
0	Initial version.
1	<ul style="list-style-type: none"> • Corrected block connections in Figure 1. • Section 3, “Features” was corrected and/or clarified. • Section 3.17, “Interrupt Controller (INTC),” was rewritten for clarity. • Revision History table: Modified/corrected description wording and removed internal information. • Removed Section 3, “Part Numbers and Packaging.” For information, refer to the MCF5213 Hardware Specifications or www.freescale.com/coldfire. • Updated back page template.
2	<ul style="list-style-type: none"> • Formatting, layout, spelling, and grammar corrections. • Updated block diagram and feature information to match Revision 2 of the MCF5213 ColdFire® Integrated Microcontroller Reference Manual. • Added Table 2, “Part Number Summary”. • Added the following footnote to the FlexCAN entry in Table 1: “FlexCAN is available on the MCF5211 only in the 64 QFN package.” • Light editing for grammar, punctuation, and style

How to Reach Us:

Home Page:

www.freescale.com

Web Support:

<http://www.freescale.com/support>

USA/Europe or Locations Not Listed:

Freescale Semiconductor, Inc.
Technical Information Center, EL516
2100 East Elliot Road
Tempe, Arizona 85284
+1-800-521-6274 or +1-480-768-2130
www.freescale.com/support

Europe, Middle East, and Africa:

Freescale Halbleiter Deutschland GmbH
Technical Information Center
Schatzbogen 7
81829 Muenchen, Germany
+44 1296 380 456 (English)
+46 8 52200080 (English)
+49 89 92103 559 (German)
+33 1 69 35 48 48 (French)
www.freescale.com/support

Japan:

Freescale Semiconductor Japan Ltd.
Headquarters
ARCO Tower 15F
1-8-1, Shimo-Meguro, Meguro-ku,
Tokyo 153-0064
Japan
0120 191014 or +81 3 5437 9125
support.japan@freescale.com

Asia/Pacific:

Freescale Semiconductor Hong Kong Ltd.
Technical Information Center
2 Dai King Street
Tai Po Industrial Estate
Tai Po, N.T., Hong Kong
+800 2666 8080
support.asia@freescale.com

For Literature Requests Only:

Freescale Semiconductor Literature Distribution Center
P.O. Box 5405
Denver, Colorado 80217
1-800-441-2447 or 303-675-2140
Fax: 303-675-2150
LDCForFreescaleSemiconductor@hibbertgroup.com

Document Number: MCF5213PB
Rev. 2
03/2007

Information in this document is provided solely to enable system and software implementers to use Freescale Semiconductor products. There are no express or implied copyright licenses granted hereunder to design or fabricate any integrated circuits or integrated circuits based on the information in this document.

Freescale Semiconductor reserves the right to make changes without further notice to any products herein. Freescale Semiconductor makes no warranty, representation or guarantee regarding the suitability of its products for any particular purpose, nor does Freescale Semiconductor assume any liability arising out of the application or use of any product or circuit, and specifically disclaims any and all liability, including without limitation consequential or incidental damages. "Typical" parameters that may be provided in Freescale Semiconductor data sheets and/or specifications can and do vary in different applications and actual performance may vary over time. All operating parameters, including "Typicals", must be validated for each customer application by customer's technical experts. Freescale Semiconductor does not convey any license under its patent rights nor the rights of others. Freescale Semiconductor products are not designed, intended, or authorized for use as components in systems intended for surgical implant into the body, or other applications intended to support or sustain life, or for any other application in which the failure of the Freescale Semiconductor product could create a situation where personal injury or death may occur. Should Buyer purchase or use Freescale Semiconductor products for any such unintended or unauthorized application, Buyer shall indemnify and hold Freescale Semiconductor and its officers, employees, subsidiaries, affiliates, and distributors harmless against all claims, costs, damages, and expenses, and reasonable attorney fees arising out of, directly or indirectly, any claim of personal injury or death associated with such unintended or unauthorized use, even if such claim alleges that Freescale Semiconductor was negligent regarding the design or manufacture of the part.

RoHS-compliant and/or Pb-free versions of Freescale products have the functionality and electrical characteristics as their non-RoHS-compliant and/or non-Pb-free counterparts. For further information, see <http://www.freescale.com> or contact your Freescale sales representative.

For information on Freescale's Environmental Products program, go to <http://www.freescale.com/epp>.

Freescale™ and the Freescale logo are trademarks of Freescale Semiconductor, Inc. All other product or service names are the property of their respective owners.
© Freescale Semiconductor, Inc. 2007. All rights reserved.

