

MCF5282 HVAC and Security Control Panel

Overview

A heating, ventilation and air conditioning (HVAC) and security control panel is the central control hub of the home's heating and cooling functions and home security functions. With it, users can remotely control the temperature, furnace, compressor and air duct valves using ZigBee™ technology based on the IEEE® 802.15.4 standard, which is a low-data-rate, low-complexity solution with multimonth to multiyear battery life ideal for applications such as sensors, interactive toys, smart badges, remote controls, home automation and portable electronics.

Security enhancing features such as window and door sensors, motion sensors and keycode verification are handled by processing simple wireless packets or simple communication with the keypad that is mounted in the home. The remote sensors are efficiently managed through ZigBee wireless communication optimized for low power, short distance control and remote monitoring networking applications, which require infrequent, low-rate and small packet data. The Ethernet connection enables Web-based local and

remote control. The analog-to-digital converter (ADC) provides interfaces to analog components used to control the home environment.

The HVAC security control system conveniently brings remote manipulation and wireless communication into the hands of the resident with the flexible ability to network and control various elements in the home—while at home or away.

Design Challenges

Microcontrollers that enable an HVAC and security control panel require connectivity and integration. They require a means to interface to wireless nodes within the home such as an LCD display, keypads and sensors. In order to capitalize on the controllability of the wireless network, the interface to Ethernet enables remote monitoring and control.

Because the HVAC and security control panel is always powered and expected to run for years, it is necessary to use low-power devices with low standby current.



MCF5282 BLOCK DIAGRAM

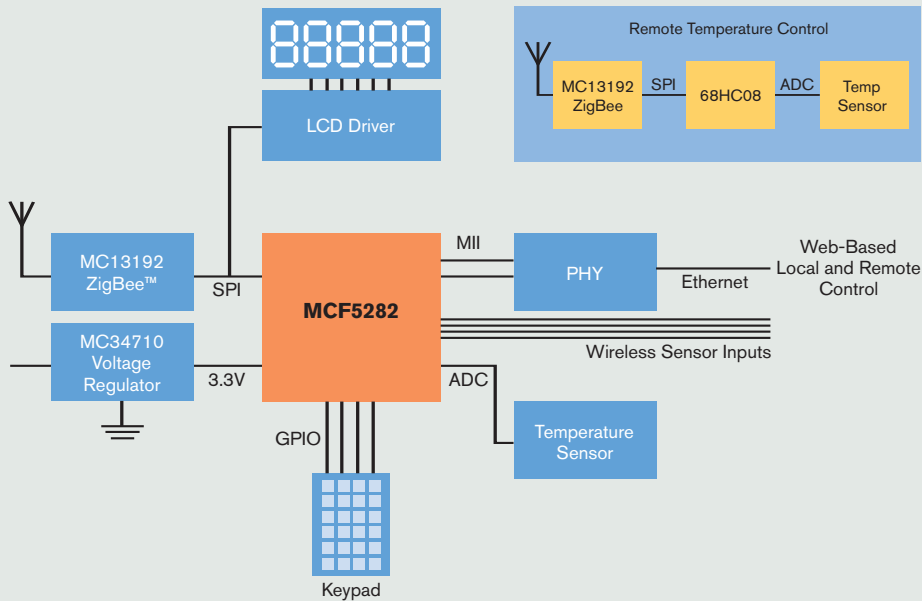

Key Benefits

- > On-chip peripherals on the MCF5282 device are engineered to allow straightforward implementation of an HVAC and/or security system including the ability to remotely access the components of the network using the TCP/IP protocol over wired 10/100 Ethernet or IEEE 802.11 wireless local area networks (LANs).
- > Large securable Flash integrated on the MCF5282 provides a means to use and update any necessary firmware for the initialization and control of the home network.
- > Connectivity such as a Controller Area Network (CAN) and even numerous general-purpose input/outputs (GPIOs) enable interfaces to various hardware devices.

Freescale Solution

The MCF5282 offers a highly integrated solution for an HVAC and security control system. The 512 KB of onboard securable Flash provides a system solution that enables firmware for initialization and control of the connected devices. The 10/100 Ethernet Media Access Controller (MAC) offers the ability to serve up Web pages and enables local and remote control of this system. The ADC provides the interface to local temperature sensors.

The 64 KB of onboard SRAM and the enhanced Multiply-Accumulate (eMAC) offer the option of running algorithms used by the security system as well as other computation-intensive tasks. The MCF5282 includes the integration required for the HVAC and security system central controller.

Learn More: For more information about Freescale products, please visit www.freescale.com.