

i.MX27 Multimedia Applications Processor

Overview

In response to the needs of design engineers tasked with pushing the performance envelope, packing in a lot of connectivity options and providing robust security in mobile device designs, Freescale presents the i.MX27 multimedia applications processor. Derived from the popular i.MX21 processor and based on the ARM926EJ-S™ core, the i.MX27 processor adds an H.264 D1 hardware codec for high-resolution video processing, an Ethernet 10/100 MAC, security, plug-and-play connectivity and more power management features. This rich feature set makes it an excellent choice for video- and voice-over-IP (V2IP) cordless and mobile phones, intelligent remote controls, point-of-sale terminals and many other wireless applications.

The i.MX27 multimedia applications processor is architected with Freescale's Smart Speed™ technology, an intelligent integrative approach that uses hardware accelerators to offload the CPU and a crossbar switch to bring parallelism to the system. The result is a processor that performs like a much higher MHz device, but conserves power for long, long battery life.

The i.MX Family

Freescale's i.MX family of applications processors delivers power to the people who demand it: designers and users alike who want exceptional performance and long battery life from their mobile devices. Design engineers capitalize on the amazing performance i.MX processors achieve at lower clock speeds and the high degree of integration to quickly deliver innovative mobile devices to market. Consumers love the lifelike video and 3-D graphics reproduction, quick response and long play time for hours of work and entertainment use. Freescale gives design engineers the power of choice with various i.MX processors, from the i.MXS for price sensitive applications, and i.MXL, i.MX1 and i.MX21S for mid-range devices, to i.MX21, i.MX27, i.MX31L and i.MX31 for high-performance mobile multimedia devices.

The i.MX family supports a range of platforms such as those based on the Microsoft® Windows® CE and Linux® operating systems as well as a number of leading RTOSs.

Features

CPU Complex

- ARM926EJ-S 400 MHz core
- 16 KB L1 I-Cache and D-Cache
- 16-channel DMA
- ETM real-time debug
- Smart Speed switch

Multimedia

- MPEG-4 H.263/H.264 D1 HW codec
- Pre and post processing
- High-speed CMOS sensor interface

External Memory Interface (EMI)

- SDRAM 16/32-bit, 133 MHz
- DDR 16/32-bit, 266 MHz
- NAND flash 8/16-bit
- PSRAM support

Security Control

- Crypto accelerator
- Electronically blown fusebox
- High-assurance boot
- Security controller with encrypted RAM storage
- Real-time OS/SW integrity checker

Advanced Power Management

- Dynamic process temperature compensation (DPTC)
- Active well bias

Connectivity

- 10 and 100 Mbps Ethernet/IEEE® 802.3MAC
- USB OTG high speed, host x 2
- 3 x MMC/SD, Memory Stick-Pro™
- PCMCIA/CF
- ATA-6 (HDD) interface
- Audio MUX
- IrDA, keypad, 1-wire
- Configurable SPI x 3, SSI/I²S x 2, UART x 6

Performance

- CPU complex: 400 MHz at 1.45 V, 266 MHz at 1.2 V
- System: 133 MHz

Technology

- 90 nm CMOS
- Package: 404 balls, 0.65 mm pitch MAPBGA, 17 mm x 17 mm package

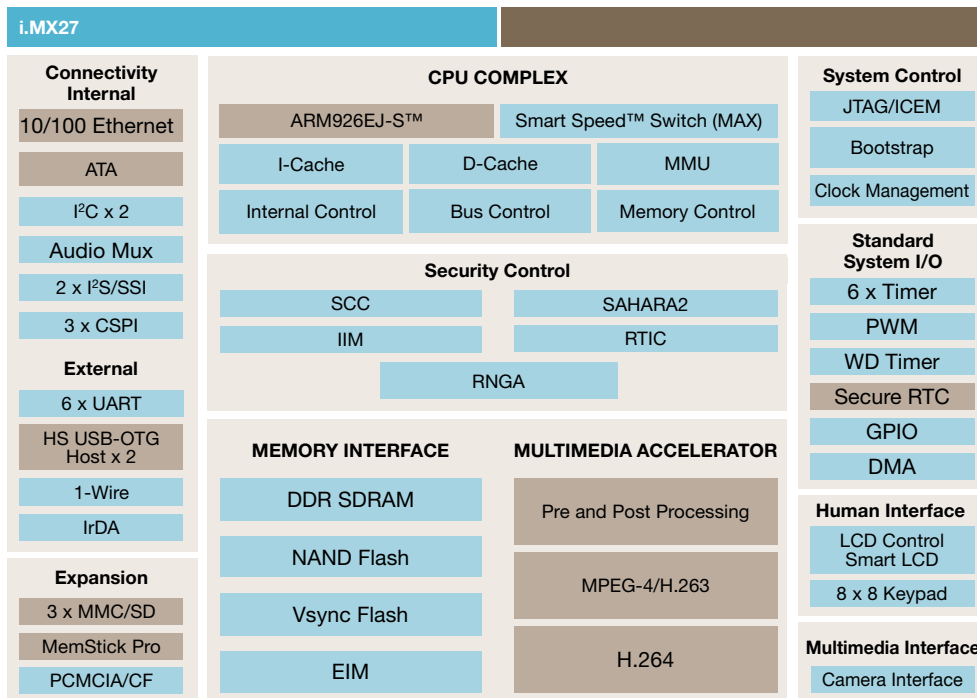

■ Inherited from i.MX21 ■ New or Enhanced from i.MX21



Enhanced Video Capabilities

The i.MX27 has a built-in, low-power eMMA2 hardware block, which consists of an MPEG-4 and H.263/H.264 encoder/decoder for D1 resolution and image pre-processing and post-processing stages. These features provide superb image and video quality. Devices with the i.MX27 are capable of long video playback time with exceptional video quality (high frame rates and large screen resolution support). The i.MX27 provides flexibility for software implementation for other video decoders, such as PacketVideo®, RealNetworks® and Windows Media™. Hardware code addresses the I/O bottleneck and helps to reduce power consumption, enabling greater device mobility.

Smart Speed Switch

The 6 x 3 Smart Speed crossbar switch in i.MX27 enables designers to achieve true parallelism resulting in more effective data transactions per clock cycle. The switch allows up to three simultaneous transactions; this virtually eliminates wait states and can provide the effective throughput of a 133 MHz bus. This allows enriched multimedia experiences, such as V2IP at low power for hours and hours on a single battery charge.

The i.MX27 offers an abundance of different power saving modes, giving the system developer the ability to make trade-offs between power consumption in stand-by and recovery times. These modes include: Run, Wait, Doze, State Retention, Deep Sleep and Hibernate.

Security Features

The i.MX27 incorporates Freescale's Platform Independent Security Architecture, a combination of security features that provides a high level of confidence for carriers, content providers and consumers. The i.MX27 security architecture is a blended hardware/software solution. Security features include:

- Memory Management Unit (MMU)
- Security Controller (SCC), including Secure RAM and Security Monitor
- Random Number Generator Accelerator (RNGA)
- Universal Unique Identification
- Run-Time Integrity Checker (RTIC)
- Crypto Accelerator
- IC Identification Module (IIM) with e-fuses
- High Assurance Boot (HAB)
- Tamper Detection

For carriers, the security architecture provides protection features to help guard against malicious service attacks, theft of services, configuration protection and concerns with cloning. For content providers, it helps block illegal access to licensed content, thereby protecting against unauthorized use and distribution. And for consumers, private data is designed to be inaccessible, helping protect against identify theft.

Power Management

The i.MX27 is built using Freescale's Smart Speed technology with some powerful innovations. Our Dynamic Process Temperature Compensation (DPTC) mechanism measures reference circuits' delays dependent on the process speed and temperature. The DPTC then lowers the voltage to the minimum level needed to support the current operating frequency.

Connectivity

i.MX27 supports connectivity to a wide range of external devices—cameras, displays and more. The i.MX27 also supports 10 and 100 Mbps Ethernet/802.3 networks, thus introducing Ethernet connectivity to the i.MX family. The i.MX27 also connects to hard disk drives through its ATA-6-compliant interface for large storage capacity devices to enhance media on the go.

USB On-the-Go (USB-OTG)

The i.MX27 integrates one High-Speed USB-OTG port for connection to a PC or PC peripherals without PC involvement, plus one High-Speed USB Host and one Full-Speed USB Host for interfacing with peripherals such as Wi-Fi®, Bluetooth® and cellular baseband.

Freescale Wireless Developer Network

The Freescale Wireless Developer Network is a global program designed to provide platforms, tools, technology and expertise to get products to market fast. This program offers platforms that include hardware, software, tools, systems integration and other services as pre-integrated solutions to help shorten product development cycles. With early access to tools, our partners are equipped to deliver cost-effective mobile wireless solutions to a world audience quickly and easily. For more information, please visit www.freescale.com/fwdn.

Learn More:

For current information about Freescale products and documentation, please visit www.freescale.com.