

Using the 16 MHz Crystal Oscillator

MC9328MX1, MC9328MXL, and MC9328MXS

By Connie Cheung and Michael Kjar

1 Abstract

The 16 MHz Crystal Oscillator module is designed to handle off-chip crystals that have a frequency of 4–16 MHz. The crystal oscillator's output is fed to the System PLL as the input reference. The oscillator design generates low frequency and phase jitter, which is recommended for USB operation.

This document contains an overview of the on-chip oscillator design and parameters for the crystal model, which are derived from both simulation and empirical data analysis. Recommendations and requirements for selecting a 16 MHz crystal are also covered. Finally, the document has guidelines and a detailed description of oscillator circuit design and PCB layout. It is strongly recommended that you follow the crystal specification and crystal PCB layout guidelines in this document.

This document applies to the following i.MX devices, collectively called i.MX throughout:

- MC9328MX1
- MC9328MXL
- MC9328MXS

Contents

1 Abstract	1
2 Circuit Design	2
3 Crystal Evaluations and Recommendations	3
4 Enabling the On-Chip 16 MHz Oscillator ...	5
5 Using an External Signal as the Clock Source	5
6 Laying Out the Printed Circuit Board with the Oscillator	6
7 Document Revision History	7



2 Circuit Design

The oscillator design on i.MX processors is known as the Colpitts Oscillator with Translated ground, illustrated in [Figure 1](#).

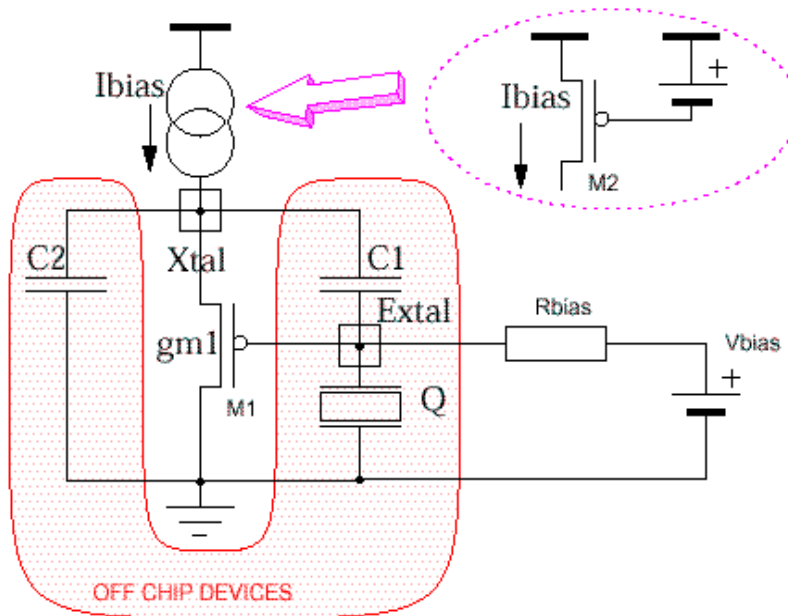

Figure 1. Simplified Oscillator Stage

2.1 Crystal Equivalent Circuit

[Figure 2](#) illustrates the crystal's equivalent electrical model.

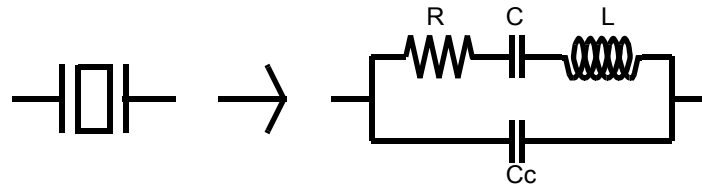

Figure 2. Crystal Electrical Equivalent Schematic

The crystal model is based on the following components:

- L: Motional Inductor
- C: Motional Capacitor
- R: Equivalent Series Resistor
- Cc: Shunt Capacitor

Operational oscillation frequency is a function of the components in [Equation 1](#):

$$\text{Freq} = 1/[2*\pi*\text{sqrt}(L*C)] \tag{Eqn. 1}$$

The conditions for oscillation are as follows:

- Amplifier Gain ≥ 1
- Total phase shift across crystal = 360 degrees

The following factors influence crystal oscillation:

1. As Cc increases, Gain decreases.
2. As R increases, Gain decreases.
3. The C1 and C2 load capacitors affect the gain and phase margin. The simulation output shows that the following settings generate the largest gain: 10 pF (for C1) and 33 pF (for C2).

3 Crystal Evaluations and Recommendations

This section describes evaluations conducted by two crystal vendors, Hong Kong X'tals Limited (referred to as crystal 1 in this text) and ILSI America (referred to as crystal 2). The vendors tested the on-chip oscillator with their own 16 MHz crystals, which meet the following requirements:

- R (equivalent series resistance, or ESR) < 20 ohm
- Cc (Shunt Capacitance) < 7 pF

The evaluation environment had the following characteristics:

- Crystal 1 was evaluated with an MC9328MX1 EVB with the i.MX processor inserted in a socket. Crystal 2 was evaluated with an ADS with the i.MX processor soldered directly onto the board.
- The external capacitor values were: C1 = 10 pF and C2 = 33 pF. (To see how the external capacitors fit into the circuit board layout, see [Figure 4](#).)

3.1 Measurement Results

The evaluations produced the following results:

- Total capacitor load = 22.5 pF.
- Measured negative resistance versus the Vo (output voltage) signal of 16 MHz, as shown in [Figure 3](#).

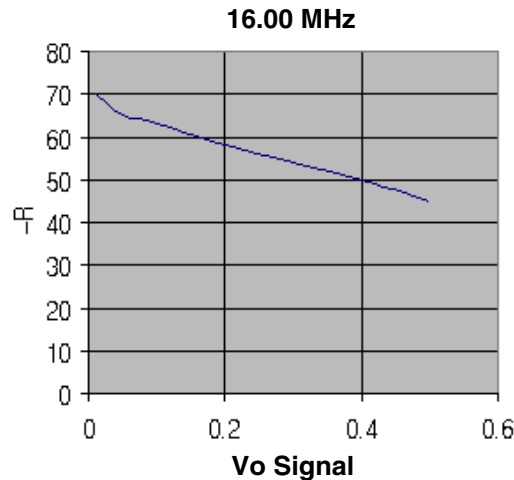

Figure 3. Negative Resistance Versus Output Amplitude for 16 MHz

The crystal evaluations produced comparable results except for the capacitive loading of the 16 MHz oscillator itself. One vendor reports this value as 22.5 pF, while the other reports it as 14 pF. This difference is probably due to slight differences in measurement environments, measurement tools, evaluation boards, and method of connecting the i.MX processor to the board.

To ensure oscillations are produced, use a crystal with a low ESR value. The required ESR value for 16 MHz crystals is a maximum of 20 ohms.

The following value ranges are recommended for external load capacitors:

- C1 = 10–17 pF
- C2 = 22–33 pF

The evaluations show that the optimum capacitance values are 17 pF for C1 and 30 pF for C2. The driving level is 2.0 uW (microwatts).

3.2 Crystal Recommendations

The following crystal recommendations are based on the evaluations described in this section. At the time of this writing, these options are available from the vendors who conducted the evaluations:

- Hong Kong X'tals Limited
16 MHz SMD 5mm × 7mm
Part number: C5M160000D16F5FHK00
Note: Ask for a crystal that has an ESR < 20 ohms and a load capacitance of 22.5 pF.
- ILSI America,
16 MHz SMD 5mm × 7mm
Part number: ILSI-C-1074
Note: Ask for a crystal that has an ESR ≤ 18 ohms and a load capacitance of 14 pF.

4 Enabling the On-Chip 16 MHz Oscillator

To use the on-chip 16 MHz oscillator with a crystal, you must use a high quality crystal with an ESR below 20 ohms. To enable the on-chip 16 MHz oscillator, the Clock Source Control Register (CSCR) must have the following settings:

- `CLKO_SEL` — Set to any value other than 011 (CLK16M).
- `OSC_EN` — To enable the on-chip 16 MHz oscillator, set to 1.
- Set `System_SEL` — To select the 16 MHz oscillator as the clock source of the System PLL, set to 1.

CAUTION

When you enable the on-chip 16 MHz oscillator, make sure `CLKO_SEL` is not set to output CLK16M. Experiments have shown that this setting can load down the on-chip oscillator during crystal start up. After the 16 MHz oscillator starts to oscillate, however, it is all right to output CLK16M. If you are not using the CLKO signal, it is advisable to disable the CLKO pin by setting `CLKO_SEL` to 110 or 111.

For more information about the Clock Source Control register and its bit definitions, refer to the PLL and Clock Control chapter in the reference manual for your specific i.MX processor.

5 Using an External Signal as the Clock Source

As an alternative to using a crystal, you can use an externally generated 16 MHz clock source as input to the on-chip 16 MHz oscillator. If you use an external 16 MHz oscillator or other clock source, use one of the following settings to put the internal oscillator in bypass mode:

- To select the clock input from the 16 MHz oscillator, set the CSCR register bit 18 to 0, `CLK16_SEL`.
- To disable the on-chip oscillator, set the CSCR register bit 17 to 0, `OSC_EN`.
- To select the high frequency signal as input to the System PLL, set the CSCR register bit 16 to 1, `System_SEL`.

For more information about the Clock Source Control register and its bit definitions, refer to the PLL and Clock Control chapter in the reference manual for your specific i.MX processor.

To use an external signal instead of a crystal, make sure the crystal is removed from the board. With this step complete, the external clock can be fed into the EXTAL16M pad with a peak amplitude that is not higher than the internal voltage or 1.9 V.

If you use a 16 MHz oscillator, it is best to provide a mechanism to shut off the oscillator during low-power modes. Shutting off the power in this way results in maximum power savings. You can achieve this by using a GPIO to enable or disable the external oscillator.

6 Laying Out the Printed Circuit Board with the Oscillator

This Colpitts Oscillator is very sensitive to the external components on the PCB. The following guidelines provide some necessary information on the PCB layout. The external component connection is shown in Figure 4 and the layout on PCB is shown in Figure 5 on page 6.

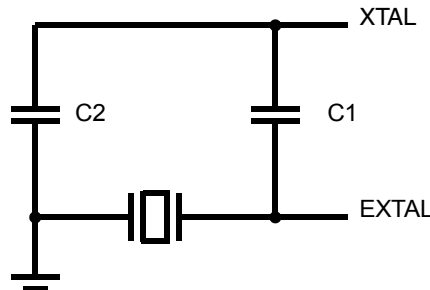

Figure 4. Schematic of External Components

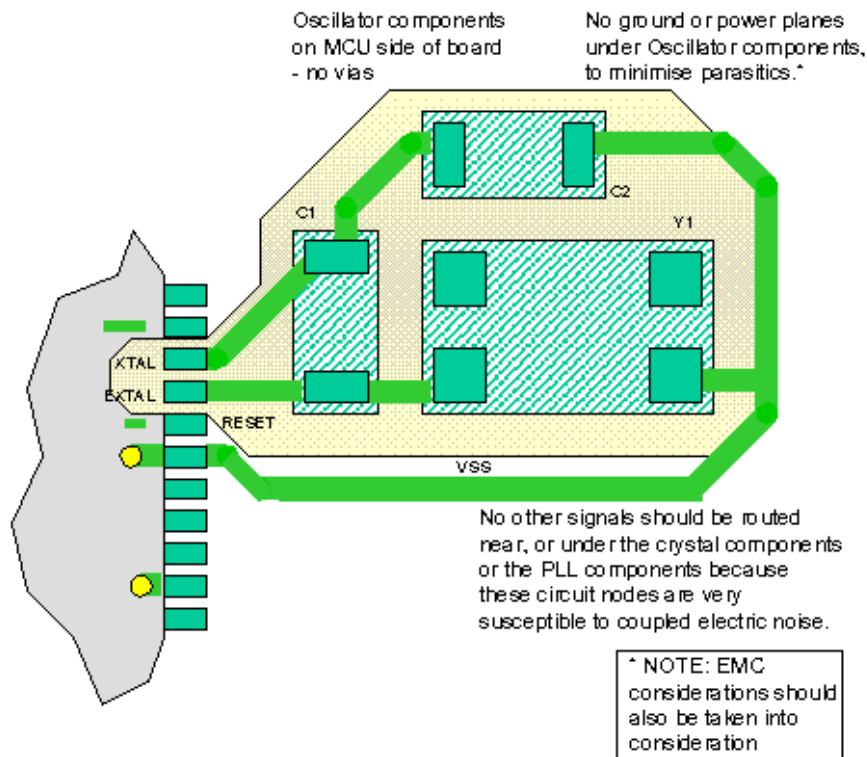

Figure 5. Recommended PCB Layout

The following list contains highly recommended guidelines for crystal circuit design and layout. Failure to meet these guidelines can result in unstable crystal operation or failed crystal start up.

- Parasitic capacitance on EXTAL is absolutely critical—probably the most critical of any layout issue. The XTAL pin is not as sensitive.
- Consider all routing from the EXTAL pin through the resonator and the blocking cap to the actual connection to VSS.

- To minimize capacitance, do not put a ground plane or power plane under the crystal, EXTAL pin, or associated routing.
- If you must place a ground plane layer under the EXTAL pin, minimize capacitance by placing the layer at a minimum distance of $3x$ the ball pitch space.
- The clock input circuitry is sensitive to noise, so it is mandatory to have excellent supply routing and decoupling.
- Bypass (decouple) the power supplies of all i.MX processors as close to the processor as possible. Use one decoupling capacitor per power supply pair (for example, VDD/VSS or VDDX/VSSX). To offer better performances over a broader spectrum, it is sometimes helpful to use two capacitors with a ratio of about 100.
- Do not cross sensitive signals *on any layer*. If you must cross a sensitive signal with another signal, cross at right angles and on the most distant layer possible.
- Do not cross the oscillator signals with any other signal on any level.
- Mount the oscillator components as close as possible to the i.MX processor.

7 Document Revision History

Table 1 summarizes revisions to this document since the previous release (Rev. 0).

Table 1. Revision History

Revision	Description
Document	Converted to Freescale format and lightly edited for clarity.
Section 5, "Using an External Signal as the Clock Source"	This section was rewritten for clarity.

How to Reach Us:

Home Page:
www.freescale.com

E-mail:
support@freescale.com

USA/Europe or Locations Not Listed:
Freescale Semiconductor
Technical Information Center, CH370
1300 N. Alma School Road
Chandler, Arizona 85224
+1-800-521-6274 or +1-480-768-2130
support@freescale.com

Europe, Middle East, and Africa:
Freescale Halbleiter Deutschland GmbH
Technical Information Center
Schatzbogen 7
81829 Muenchen, Germany
+44 1296 380 456 (English)
+46 8 52200080 (English)
+49 89 92103 559 (German)
+33 1 69 35 48 48 (French)
support@freescale.com

Japan:
Freescale Semiconductor Japan Ltd.
Headquarters
ARCO Tower 15F
1-8-1, Shimo-Meguro, Meguro-ku,
Tokyo 153-0064, Japan
0120 191014 or +81 3 5437 9125
support.japan@freescale.com

Asia/Pacific:
Freescale Semiconductor Hong Kong Ltd.
Technical Information Center
2 Dai King Street
Tai Po Industrial Estate
Tai Po, N.T., Hong Kong
+800 2666 8080
support.asia@freescale.com

For Literature Requests Only:
Freescale Semiconductor Literature Distribution Center
P.O. Box 5405
Denver, Colorado 80217
1-800-521-6274 or 303-675-2140

Information in this document is provided solely to enable system and software implementers to use Freescale Semiconductor products. There are no express or implied copyright licenses granted hereunder to design or fabricate any integrated circuits or integrated circuits based on the information in this document.

Freescale Semiconductor reserves the right to make changes without further notice to any products herein. Freescale Semiconductor makes no warranty, representation or guarantee regarding the suitability of its products for any particular purpose, nor does Freescale Semiconductor assume any liability arising out of the application or use of any product or circuit, and specifically disclaims any and all liability, including without limitation consequential or incidental damages. "Typical" parameters that may be provided in Freescale Semiconductor data sheets and/or specifications can and do vary in different applications and actual performance may vary over time. All operating parameters, including "Typicals", must be validated for each customer application by customer's technical experts. Freescale Semiconductor does not convey any license under its patent rights nor the rights of others. Freescale Semiconductor products are not designed, intended, or authorized for use as components in systems intended for surgical implant into the body, or other applications intended to support or sustain life, or for any other application in which the failure of the Freescale Semiconductor product could create a situation where personal injury or death may occur. Should Buyer purchase or use Freescale Semiconductor products for any such unintended or unauthorized application, Buyer shall indemnify and hold Freescale Semiconductor and its officers, employees, subsidiaries, affiliates, and distributors harmless against all claims, costs, damages, and expenses, and reasonable attorney fees arising out of, directly or indirectly, any claim of personal injury or death associated with such unintended or unauthorized use, even if such claim alleges that Freescale Semiconductor was negligent regarding the design or manufacture of the part.

Freescale™ and the Freescale logo are trademarks of Freescale Semiconductor, Inc. The ARM Powered Logo is a registered trademark of ARM Limited. All other product or service names are the property of their respective owners.

© Freescale Semiconductor, Inc. 2005. All rights reserved.