

METERING
INTERNATIONAL

WORLD METER
DESIGN CONGRESS

Opportunities in creating an effective metering system based on a chip-level solution



Meera Balakrishnan
Global Segment Lead
Freescale Semiconductor
Munich, Germany



Opportunities in creating an effective metering system based on a chip-level solution

Agenda

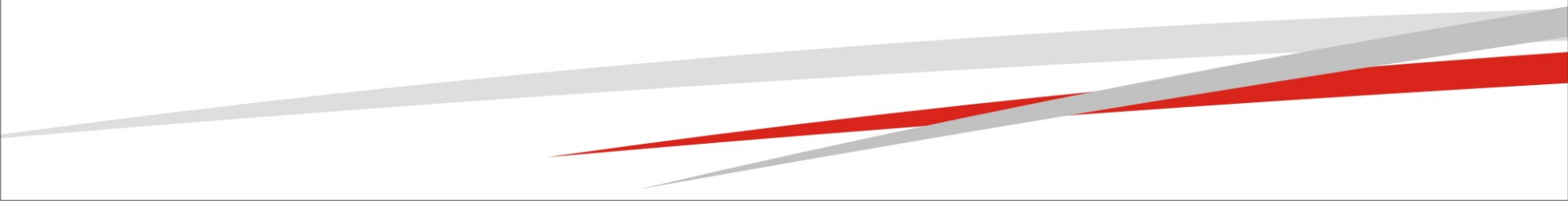
- Energy Metering – Trends & Factors
 - Challenges in Energy Metering
 - An effective metering system based on a chip-level solution
 - MCF51EM256 Poly-phase Reference Design
 - Summary
- 

Key Technology and Solution Trends in Metering

Market Trend	Description	Freescale's Portfolio Evolution and Alignment
Wired and Wireless Protocols	Wired and Wireless communications are the key technologies used in today's AMI and AMR designs	PLM – SFSK, OFDM, MBUS (wired & wireless) Zigbee SE profile, MC1322x; Freescale is focused developing NPIs for <1GHz frequency range to support AMI and AMR networks.
Low Power Consumption	With the shift to electrical gas and water meters, power consumption is a key decision factor due to battery life requirements and costs	Key focus area for Freescale. 9S08GW family with S08L core suitable for long-life gas, water meter applications. Freescale is indicating ideal products with an Energy Efficient Solutions brand mark.
Peripherals Integration	Focus on cost driving higher levels of integration	Differentiator and strength of Freescale across multiple product groups. Key example is the release of the MC1322x and MCF51EM256 with ADC integrated.
Communication Within Home	Home/energy gateways are using existing infrastructure	Freescale offers i.MX25 and MPC8308 products for Energy gateway. Monitoring standards for HAN (Homeplug, GreenPHY)
Emerging Applications that need interface to smart grids	Intelligent appliances within the home, micro-grid generation (solar cells), Plug-in Hybrid vehicles require appropriate interface and measurement technologies	Digital signal controllers and microcontrollers portfolio support these applications. Working closely with industry leaders to further develop solutions in this space.
Smart Grids Infrastructure development	Protocols emerging for control and communication of various components in Smart Grids	Freescale high-end products (MPC83xx, QoRIQ) ideal fit for these applications which require IEEE 1588, Ethernet, Security support.

Freescale in Smart "Grid" Energy

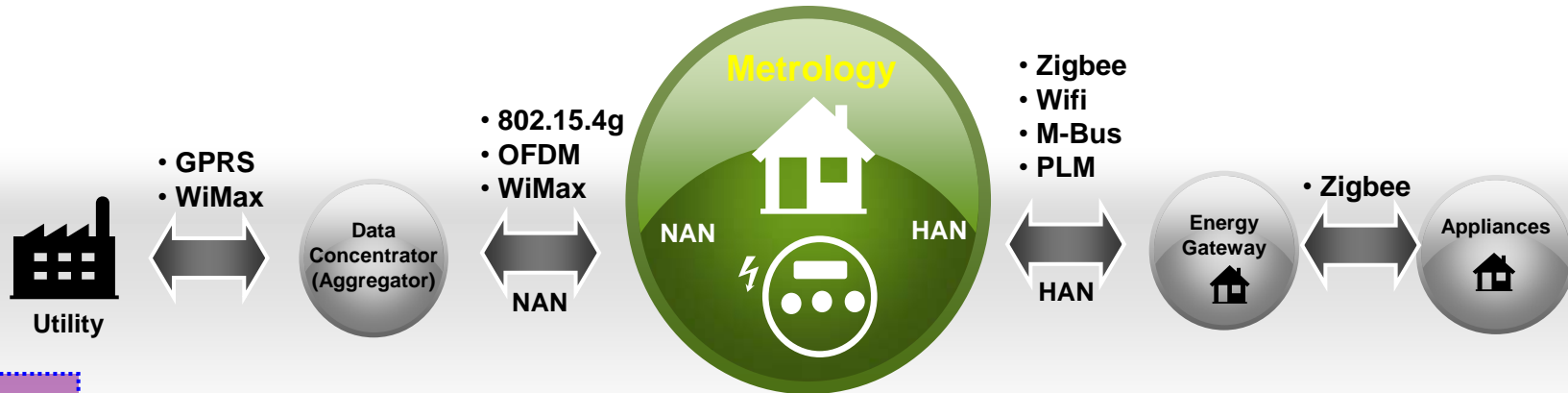

NAN (Neighborhood Area Network) :
Wireless or wired network to collect meter consumption information

Metrology:
Hardware that measures and controls flow of energy to/from building

HAN (Home Area Network) :
Wireless or wired network used for load control and dynamic response by utilities

Utility / NAN	Metrology	Home Area Network (HAN)
<ul style="list-style-type: none"> ▪ Data Concentrators & Aggregator <ul style="list-style-type: none"> ▪ i.MX257 ▪ MPC8308, MPC8313 ▪ P1021, P1012 ▪ Interfaces to NAN <ul style="list-style-type: none"> ▪ 802.15.4g Radio ▪ Wimax ▪ PLM Partnership ▪ Interfaces to Utility <ul style="list-style-type: none"> ▪ Wimax ▪ GPRS ▪ DLMS/COSEM library 	<ul style="list-style-type: none"> ▪ Low End Metering <ul style="list-style-type: none"> ▪ LL/LH/AC ▪ Water, Gas & Heat <ul style="list-style-type: none"> ▪ GW ▪ Smart 1-3ph Metering <ul style="list-style-type: none"> ▪ MCF51EM256 ▪ Next gen 512/1MB 	<ul style="list-style-type: none"> ▪ Smart Energy Gateway <ul style="list-style-type: none"> ▪ ZigBee ▪ Wifi ▪ GPRS ▪ M-Bus ▪ HomePlug Green PHY ▪ Building Control Leadership <ul style="list-style-type: none"> ▪ Coldfire, i.mx ▪ Appliance Technology <ul style="list-style-type: none"> ▪ 8-32bit MCUs & DSCs ▪ Touch Sensor ▪ RF4CE (wireless control) ▪ Multi-media Processors <ul style="list-style-type: none"> ▪ i.MX ▪ High-end Processors <ul style="list-style-type: none"> ▪ MPC8308

Energy Meter Types and Measurements

Type of Electricity Meters

Electromechanical meters

- *Being replaced by electronic meters today*
- *Limited accuracy*
- *Manual reading*
- *Contains moving parts (aluminum ring)*

Electronic meters

- *Uses MCUs, DSPs and ASICs for the metrology*
- *Accurate measurement*
- *Enhanced security*
- *Equipped with AMR*
- *No moving parts*

Measured Quantities

- *Active, Reactive, Apparent Energy*
- *Active, Reactive, Apparent Power*
- *RMS, Peak Values (voltage/current)*
- *Line frequency*
- *Power Factor*
- *Temperature*

Measurement Types

Single phase

- *Common in EU residential meters*
- *One voltage and one current measurement*
- *Use of shunt resistors prevail due to system low-cost*

Dual phase

- *Common in US residential meters*
- *Two voltage and two current measurement*
- *Use of current transformers and Rogowski coils prevail*

Three phase

- *Used in industrial meters*
- *Three voltage and three current measurement*
- *Use of current transformers and Rogowski coils prevail*

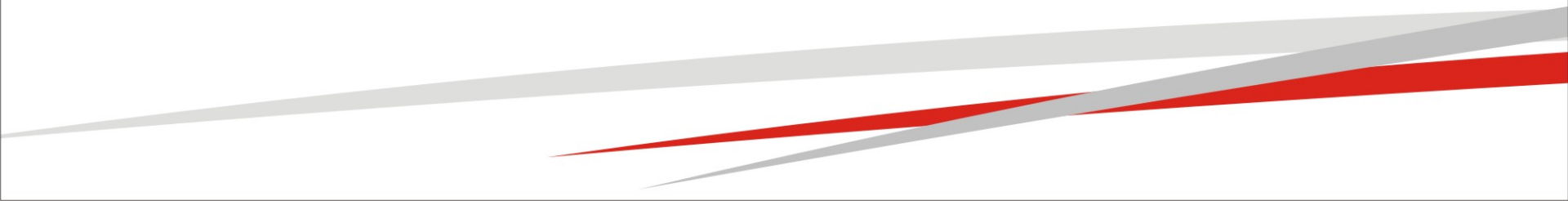

The Challenges of Electricity Meter Makers

1. Lower system cost
 2. Accurate sensor measurements
 3. Energy calculation
 4. Advanced sensor interfacing
 5. Grounding and noise issues
 6. Insufficient number of serial communication modules (I2C, SCI and SPI)
 7. Low power RTC with onchip compensation and calendaring
 8. Tamper detection capability and fault tolerance
 9. In-field secure code update capability.
 10. Insufficient uncommitted GPIOs after basic metering function
- 

Three-Phase Electricity Meter

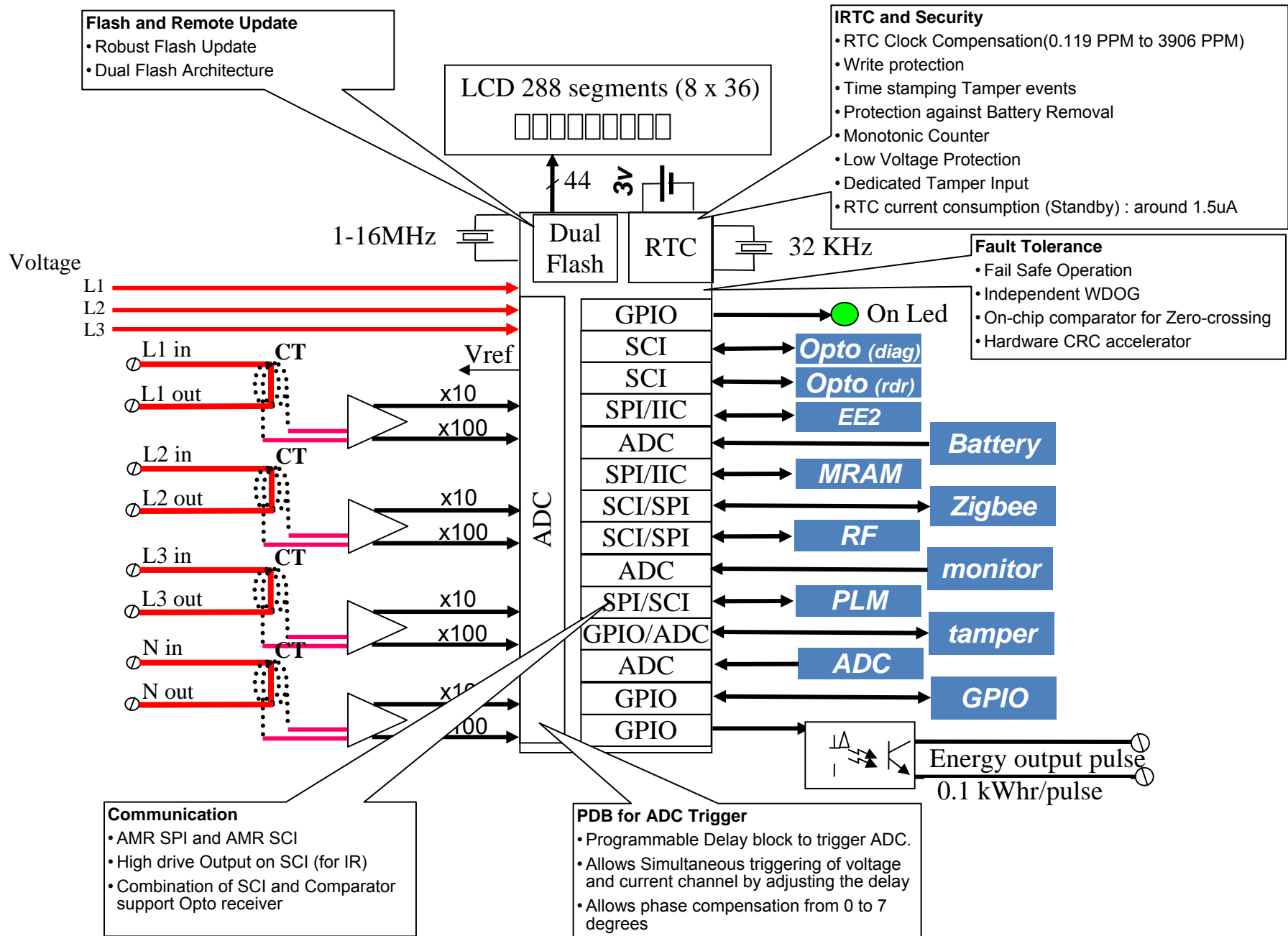

Flash and Remote Update

- Robust Flash Update
- Dual Flash Architecture

LCD 288 segments (8 x 36)

□□□□□□□□

IRTC and Security

- RTC Clock Compensation(0.119 PPM to 3906 PPM)
- Write protection
- Time stamping Tamper events
- Protection against Battery Removal
- Monotonic Counter
- Low Voltage Protection
- Dedicated Tamper Input
- RTC current consumption (Standby) : around 1.5uA

Fault Tolerance

- Fail Safe Operation
- Independent WDOG
- On-chip comparator for Zero-crossing
- Hardware CRC accelerator

Communication

- AMR SPI and AMR SCI
- High drive Output on SCI (for IR)
- Combination of SCI and Comparator support Opto receiver

PDB for ADC Trigger

- Programmable Delay block to trigger ADC.
- Allows Simultaneous triggering of voltage and current channel by adjusting the delay
- Allows phase compensation from 0 to 7 degrees

Energy output pulse
0.1 kWhr/pulse

MCF51EM256/128: Metrology & RTC

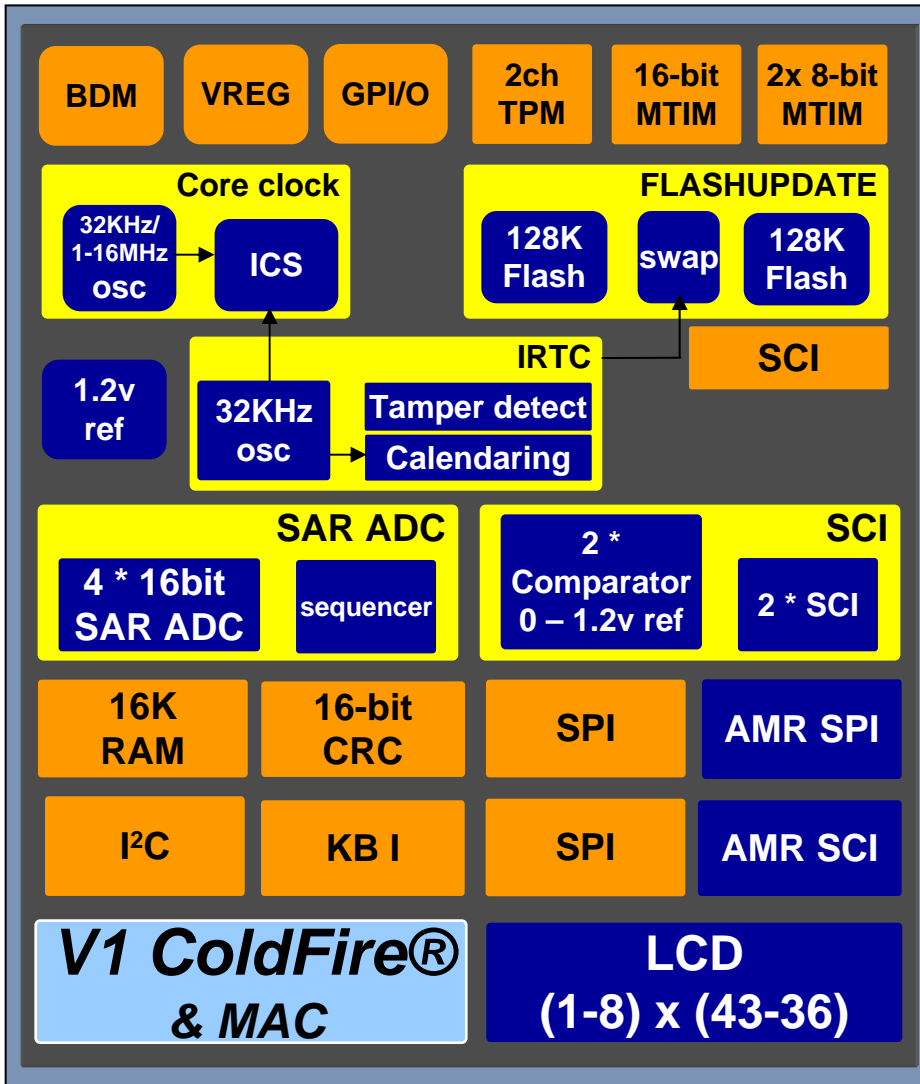

Coldfire V1 Core with

- 32-bit MAC (16x16 signed/unsigned)
 - 50MHz performance providing power calculation and communications capability
- ▶ **IRTC**
- Provides a real time calendar to allow utilities to implement different tariffs
 - Tamper detection mechanism to detect fraud
- ▶ **FLASHUPDATE**
- Implements a robust method of code update
 - No meter readings can be lost
 - No code runaway upon power outage
- ▶ **AMR SPI**
- Provides a 5v interface to external AMR modems
- ▶ **Comparators with internal programmable reference (IR)**
- Allows a simpler optical interface
- ▶ **16-bit high speed SAR ADC**
- Simultaneous conversion
 - CT phase shift compensation
- ▶ **Low Power**
- The industry's benchmark low power implementation
- ▶ **Packages**
- 80LQFP, 100LQFP

MCF51EM256 Key Features for E-metering

MCF51EM256	Customer needs
Independent Robust Real Time Clock	Tariff management, Tamper time stamping, Time and Date keeping in standby modes
Fast & High Resolution ADC with Simultaneous Sampling	Measurement up to 64 th harmonics, differential channel inputs, simultaneous current and voltage measurements.
Programmable Delay Block	Measurement triggering, sensor phase shift compensation and reduction interrupt overhead.
Secure Flash Update	Reliable in field code/tariff table updates without stopping measurement and energy counting
Connectivity (SPI, SCI, IIC)	Communication peripherals supporting IR communication and easy interfacing to 3.3V and/or 5V logic.
Multiple Clock Source	Enables MCU to function with loss of crystal(s) clock.
32-bit, 50MHz Coldfire V1 core with MAC	Single core to perform calculations, meter management and communications.
Professional Development Tools	Simplicity, robustness, development tools, FreeMaster

Independent Robust Real Time Clock

Block Diagram

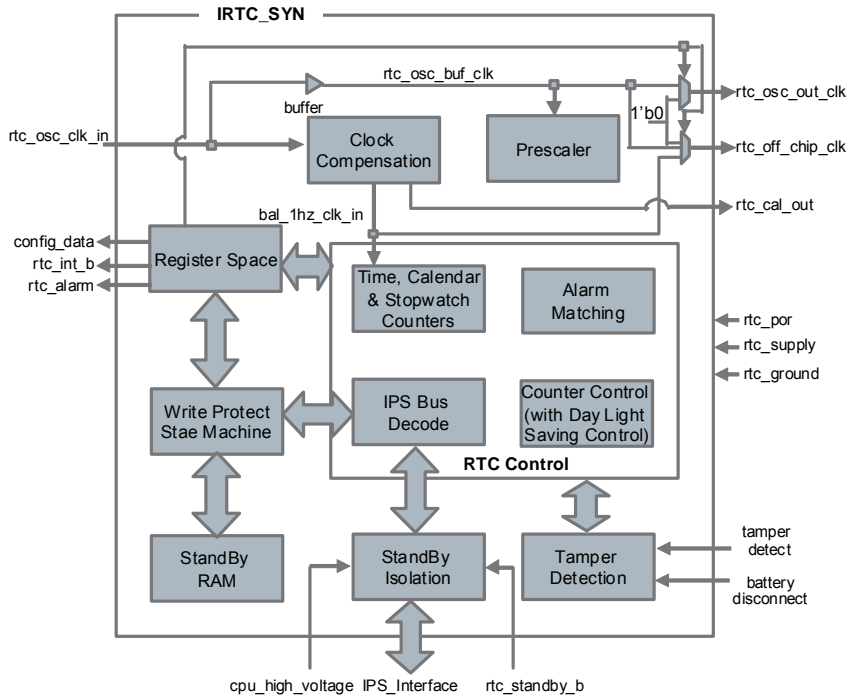

Tamper Detection Unit

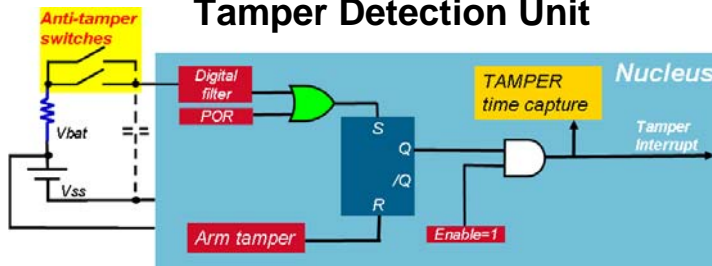

Non volatile 32-bit Counter



- Full clock – hour, minutes and seconds with option for storing values in BCD or binary format
- Calendaring – day, month, year and day of the week with option for storing values in BCD or binary format
- Auto adjustment for day light saving with user defined parameters
- Automatic month and leap year adjustment
- Programmable alarm with interrupt - output from IRTC in case MCU wants to use it as a wakeup event
- Seven periodic interrupts
- Minute countdown timer with minute resolution
- 32.768 kHz input clock with option to output the clock for use in the MCU's ICS
- Hardware compensation to compensate 1 Hz clock against frequency variations in oscillator clock due to temperature or crystal characteristics (correction in range from $\pm 12\text{ppm}$ up to $\pm 3900\text{ppm}$).
- Reset to the IRTC block is generated only when both battery supply and CPU power are removed and either is powered up
- Battery operation (standby mode) ensures seamless IRTC operation when CPU power is removed
- Tamper detection to detect illegal access into the system (time stamp stored on tamper event)
- Non volatile 32-bit Counter (can be used for energy counting)
- 32 bytes of standby RAM
- Supply current $1.5\mu\text{A}$ (powered from V_{BAT})

16-Bit SAR Analog-to-Digital Converter

Block Diagram

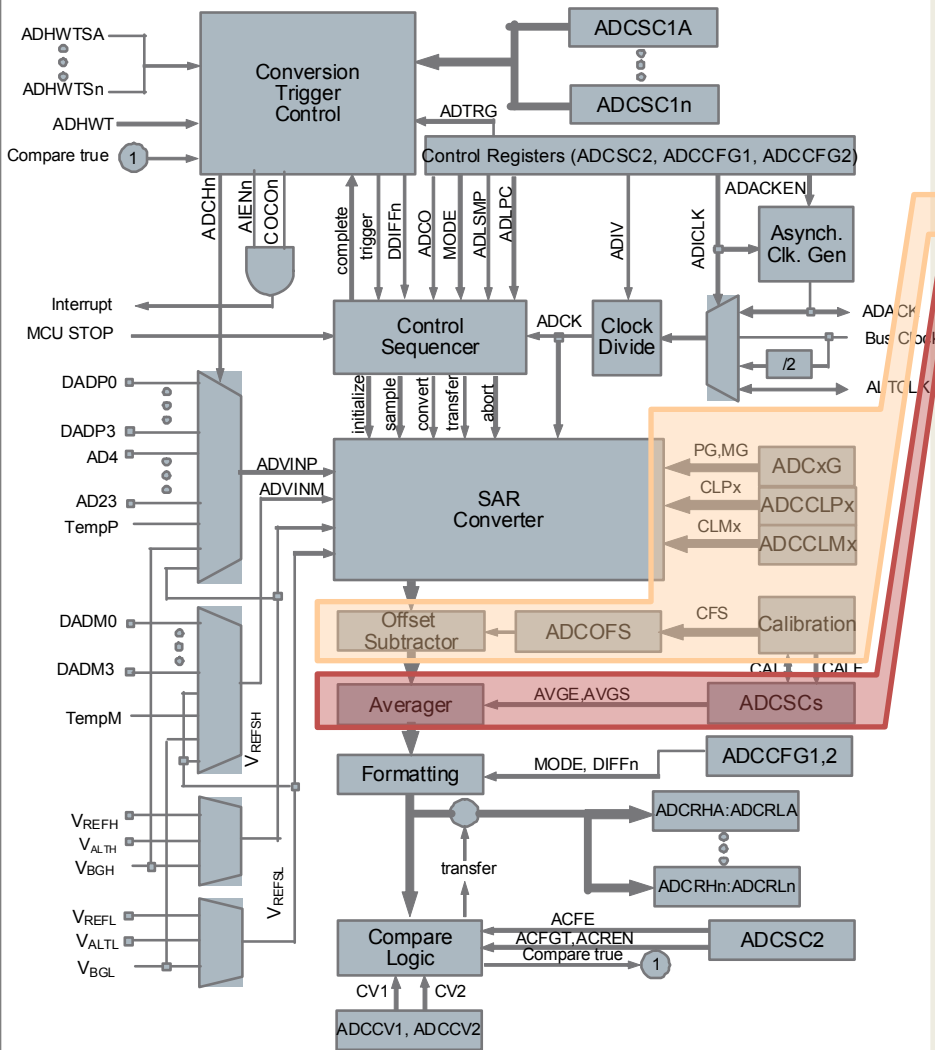

- Linear successive approximation converter with up to 16-bit resolution
- Up to 4 pairs of differential and 24 single-ended external analog inputs
- ADC clock range is 1-8MHz, so conversion times range from 2.7us to 1.9ms with a bus clock of 25MHz.
- Self-Calibration mode (offset and gain calibration)
- Hardware average function to increase resolution (up to 32x)
- Selectable voltage reference, Internal, External, or Alternate
- Dual result registers - two sequential conversions
- Output Modes: Differential 16-bit, 13-bit, 11-bit and 9-bit modes, or Single-ended 16-bit, 12-bit, 10-bit and 8-bit modes
- Output formatted in 2's complement 16b sign extended for differential modes
- Output in right-justified unsigned format for single-ended
- Single or continuous conversion (automatic return to idle after single conversion)
- Configurable sample time and conversion speed/power
- Conversion complete / Hardware average complete flag and interrupt
- Input clock selectable from up to four sources
- Operation in wait or stop3 modes for lower noise operation
- Asynchronous clock source for lower noise operation with option to output the clock
- Selectable asynchronous hardware conversion trigger with hardware channel select
- Automatic compare with interrupt for less-than, greater-than or equal-to, within range, or out-of-range, programmable value
- Integrated Temperature sensor

Programmable Delay Block – Usage in Application

PDB - ADC Integration

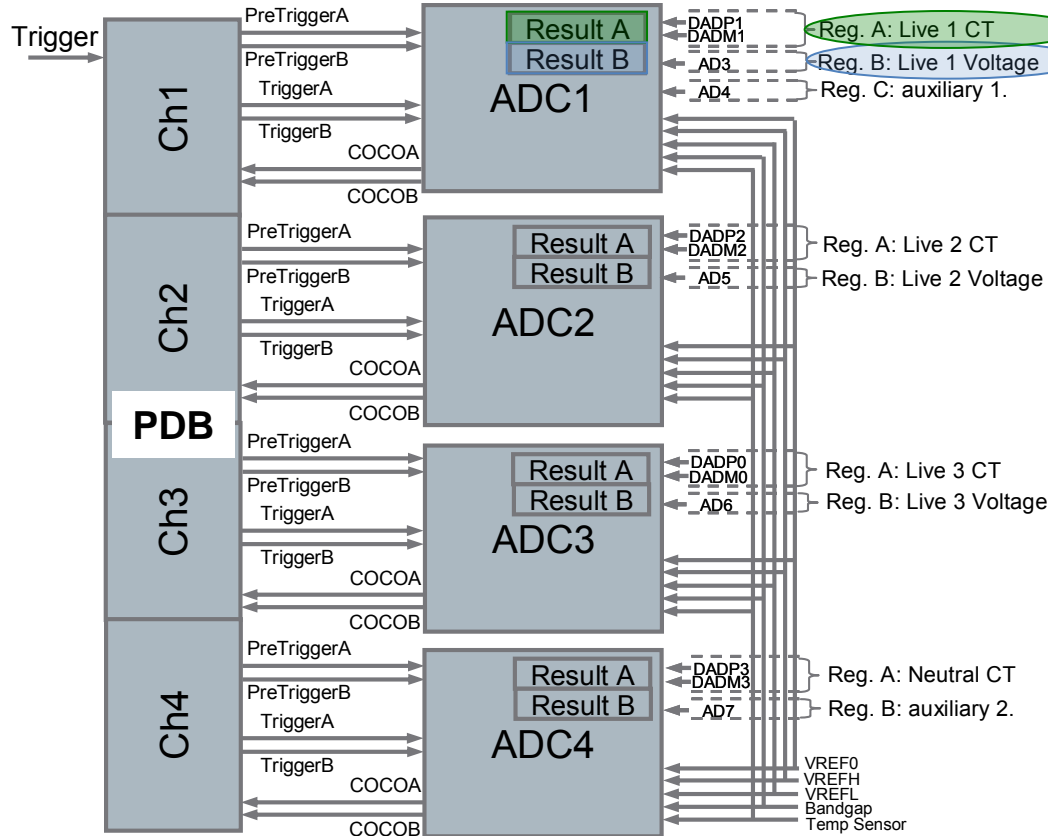

- Significantly reduces interrupt loading!
- ADC has two result registers
- One interrupt per measurement period

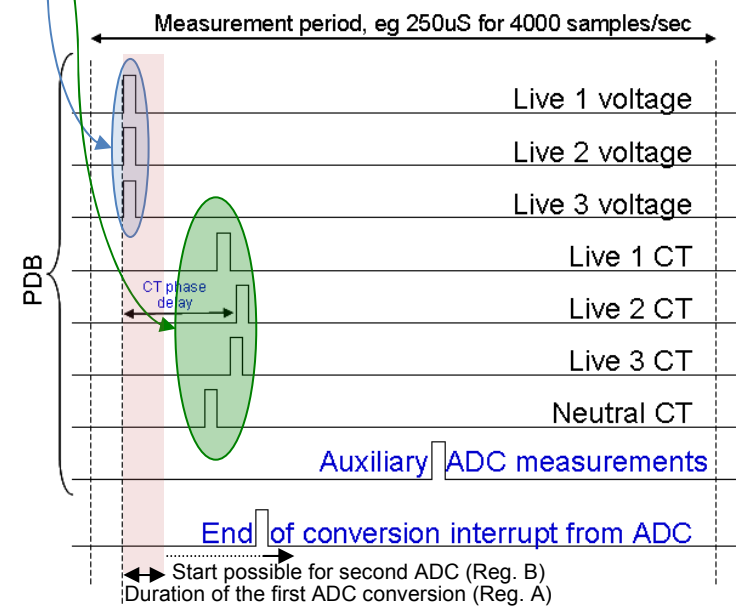

Secure Flash Update – New Firmware Update

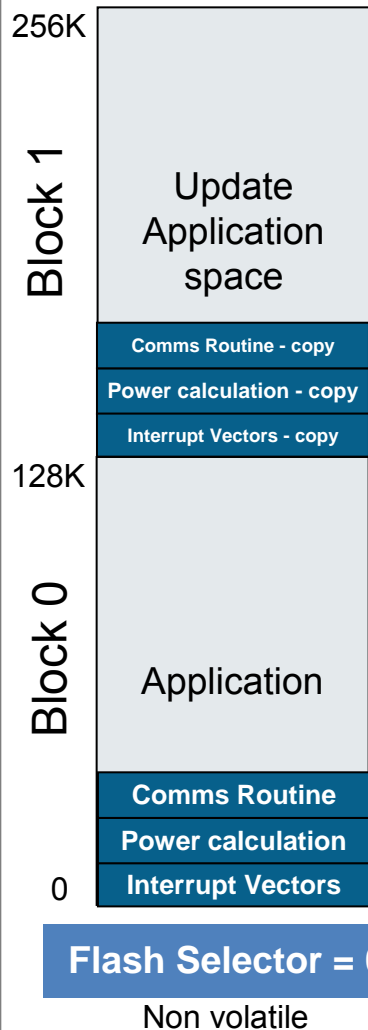

Update method - 1

1. Code in block 0 writes new application to block 1 [left diagram]
 2. **AFTER** new code validated, flash selector set to 0 (swapping blocks)
 3. New/updated code in block 1 is executed in low address space [right diagram]
- New application can replicate itself into block 0 for further fault tolerance
 - Swapping of flash blocks is controlled and maintained over power cycles

Notes

- After MCU POR & RTC POR, flash selector = 0
- Flash selector is:
 - Powered by RTC power supply
 - MCU reset does NOT change state
 - Power is maintained through MCU power cycles
- Only upper flash block is erased / written
- Software controlled switch between blocks, instantaneous (~ 40nS)
- Flash can be used as a single code space

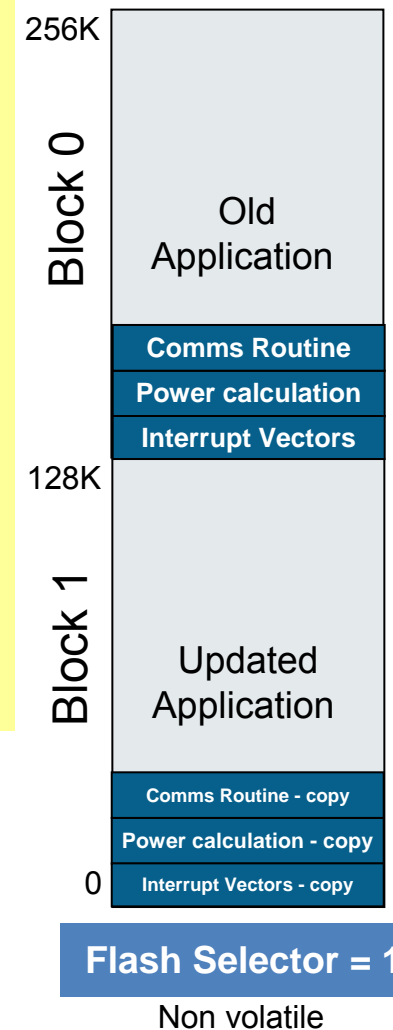

Secure Flash Update – EEPROM Emulation

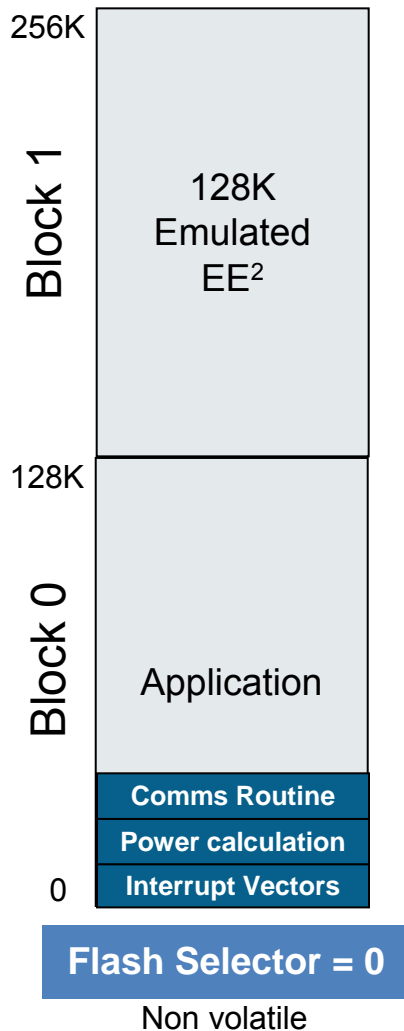

The second flash block can be used exclusively for data storage if firmware updates are not required by the application.

MCF51EM256 AMR Specific Connectivity

SCI Modules

- three modules on all packages
- wakeup from stop3 on Rx edge.
- SCI2: Tx pin in open drain mode to support interfacing to AMR (eg PLM or RF) operating at 5V
- IR communication support**
 - SCI1 and SCI2: Tx pins can be modulated with timer outputs for use with IR interfaces (frequency determined by the timer)
 - SCI1 and SCI2: Rx pins can be routed from a programmable comparator (opto receiver).

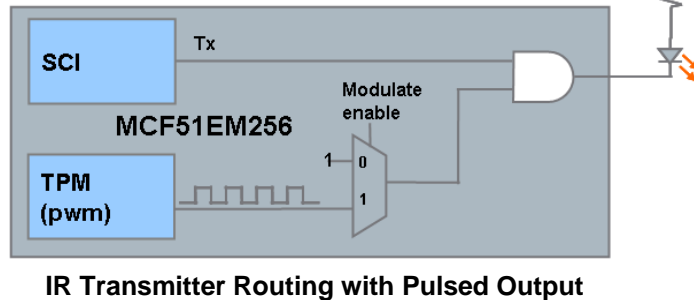
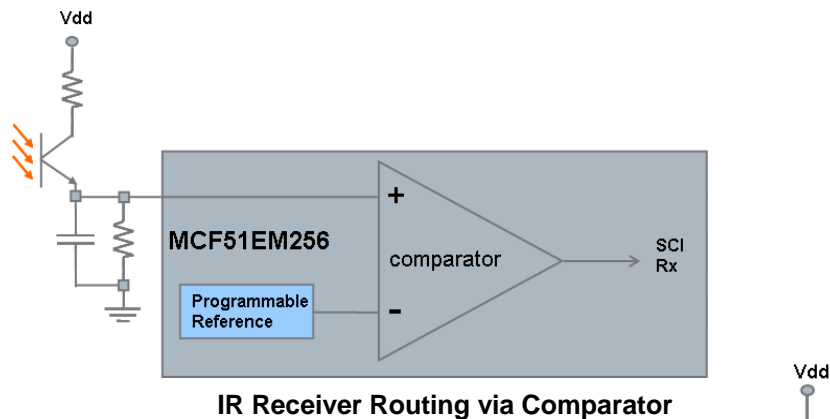

SPI Modules

- three modules on 100-pin LQFP package (two modules on 80-pin LQFP package)
- with full-duplex or single-wire bidirectional; double-buffered transmit and receive; master or slave mode; MSB-first or LSB-first shifting
- SPI1: with 32-bit FIFO buffer, 16-bit or 8-bit data transfers
- SPI2 and SPI3: standard SPI with no FIFO and 8-bit data transfer
- SPI3: open drain outputs on SCLK and (MISO OR MOSI). These, coupled with off-chip pull-up resistors, allow half-duplex interface to a 5 V SPI interface.

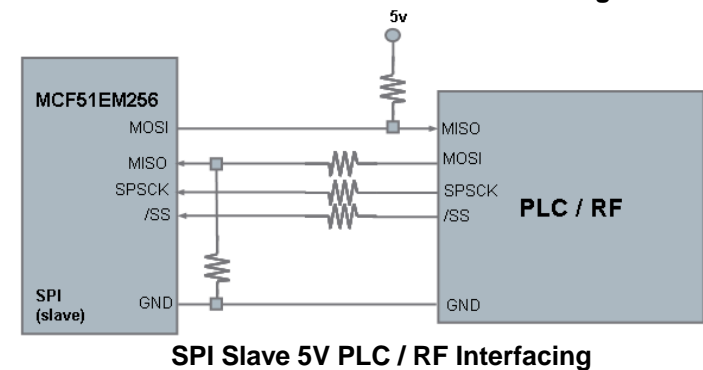
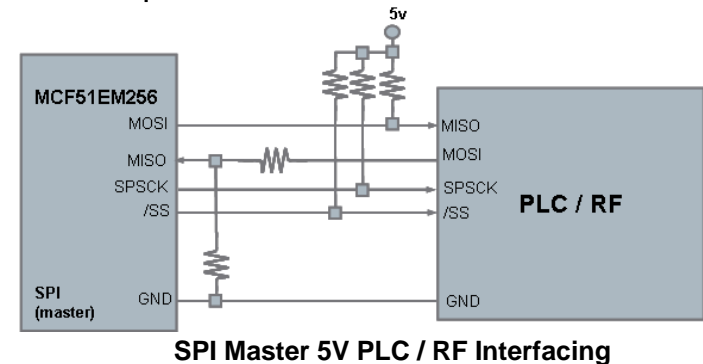

Multiple Clock Sources with Fail Safe Operation

Block Diagram

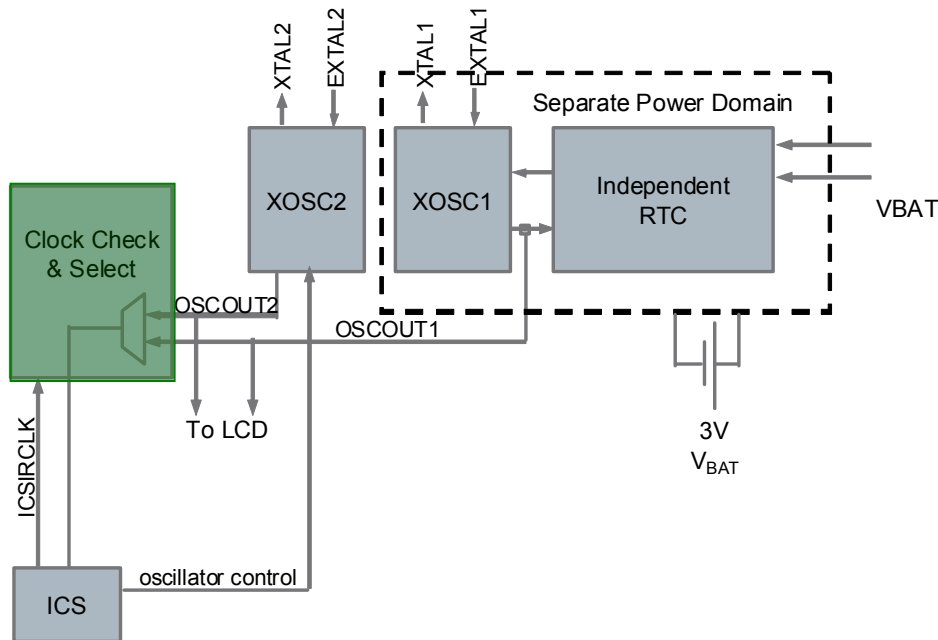

- Device powers-up from internal RC oscillator after reset.
- Clock Options:
 - External 32.768 kHz crystal (XTAL1-EXTAL1)
 - External 1-16 MHz crystal (XTAL2-EXTAL2)
 - Internal 32 kHz RC oscillator (max. +/- 2% total deviation of trimmed DCO output frequency over voltage and temperature range)
- Internal reference clock has 9 trim bits available
- Clock Check & Select Block checking health of 3-possible clock sources using self test that can run at any time:
 - Three 8-bit registers counts 3-possible clock sources for the same amount of time
 - When any counter hits the maximum value of 0xFF the test is terminated
 - Software can then compare the three registers to obtain a crude (~1.2%) measure of how well these three frequencies correlate.
- Internal Clock Source (ICS) contains Frequency-locked loop (FLL) block which drives processor core speed up to 50.33 MHz (peripherals operate at half of this speed) at 3.6 V to 2.5 V and 20 MHz at 2.5 V to 1.8 V

32-bit, 50MHz Coldfire V1 core with MAC

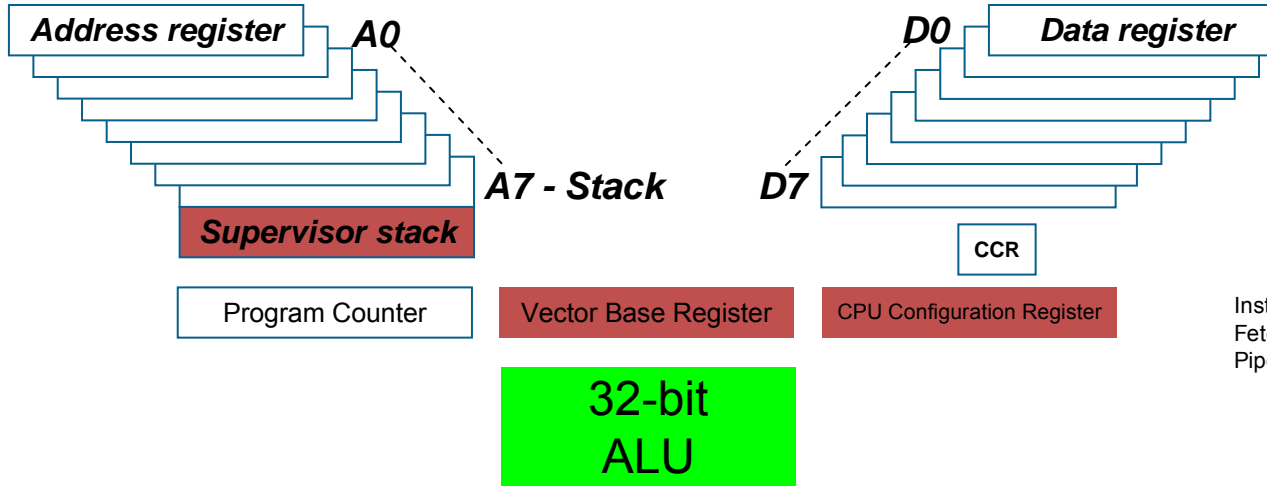

- Coldfire® architecture, instruction & operand pipeline
- 32-bit ALU
- 32-bit address & data registers
- 50MHz core speed
- Un/signed 32-bit MAC (16x16)
- Long word operations and operand handling
- 8 Data registers, no need to move each accumulators result to memory before a new operation.
- No need for paged memory, Faster access to data tables and code.

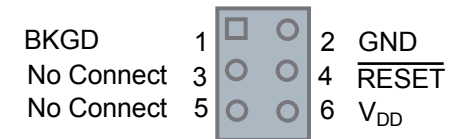
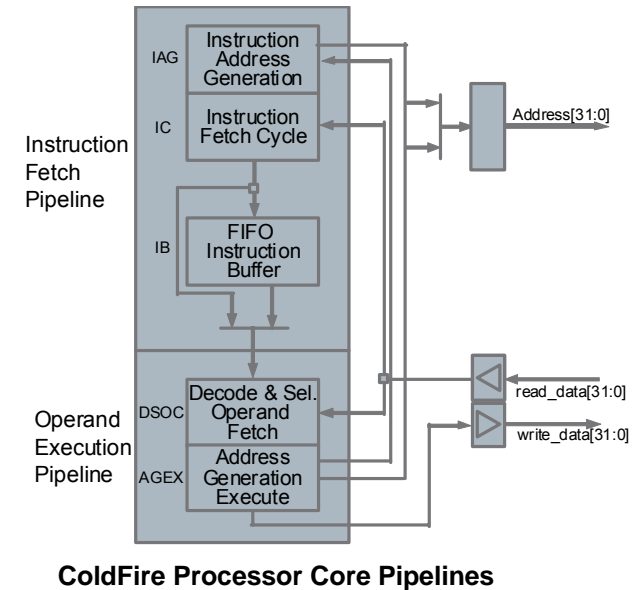

BDM Debugging Interface

MCF51EM256 Performance with Metering Algorithms

- Implemented mostly in “C”:
 - Voltage and Current RMS values
 - Active Energy, Active Power, Apparent Power, Reactive Power and Power Factor

Algorithm	Execution Time [uS]	# per phase	# of phases	Total	% of total available time
Energy per phase	610	1	3	1950	11.7%
Active power per phase	3	1	3	9	0.1%
Total RMS per signal with 256 samples	280	0	3	0	0.0%
Total RMS per signal with 128 samples	170	0	3	0	0.0%
Total RMS per signal with 64 samples	110	2	3	780	4.7%
Total RMS per signal with 32 samples	80	0	3	0	0.0%
Apparent Power	1	1	3	3	0.0%
Reactive Power	40	1	3	120	0.7%
Power Factor	90	1	3	270	1.6%
DFT per signal (256 samples) per signal	1320	0	3	0	0.0%
DFT per signal (128 samples) per signal	170	0	3	0	0.0%
DFT per signal (64 samples) per signal	85	6	3	1800	10.8%
DFT per signal (32 samples) per signal	46	0	3	0	0.0%
THD (includes fundamenta RMS) per signal	80	1	3	240	1.4%
Application free time				11495	69.0%
Total metering algorithms time				5172	31.0%
Total time				16667	100.0%

Table 16: Summary of MCF51EM256 performance.

✓ *Documentation and Code Available*

For more information refer to:

http://www.freescale.com/files/32bit/doc/app_note/AN3896.pdf

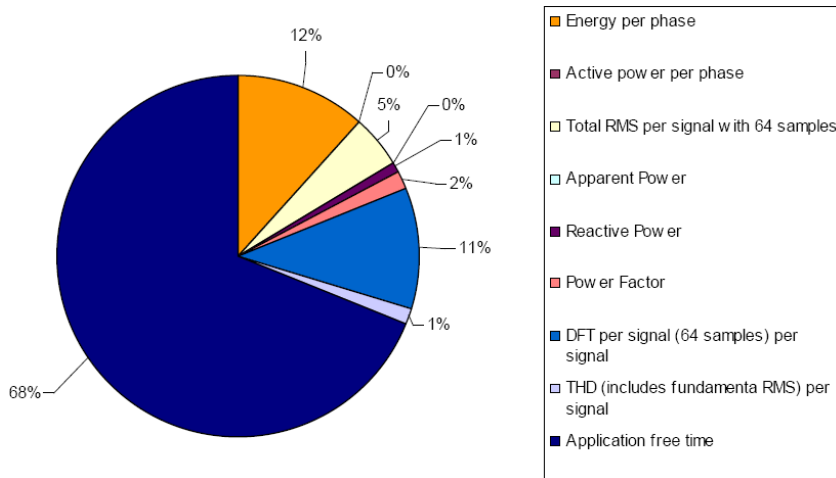

CodeWarrior for Microcontrollers V6.3 - Special Edition

Special Edition Features:

- New Project Wizard
- MCU Change Wizard
- Unlimited assembler (absolute, relocatable, mixed and in-line) for HC(S)08, RS08, ColdFire V1 microcontrollers
- Highly optimized ANSI C compilers and C source level debugger
 - HC(S)08 – 32K
 - ColdFire V1 – 64K
- Emulator-like complex debug capability for HCS08 and ColdFire V1 microcontrollers
- Fast Flash programming:
 - HC08: Via MON08
 - HCS08, RS08, ColdFire V1: Via BDM
- Full-chip Simulator for HC(S)08/RS08
- UNIS Device Initialization tool to generate HC(S)08, RS08, ColdFire V1 CPU and peripheral initialization code
- UNIS Processor Expert™ with components for HC(S)08 and ColdFire V1 CPUs and most on-chip peripherals

Licensing Procedure:

- Key is permanent, free of charge and automatically installed with the software

Support:

- 1 year support included

C-Compiler Upgrade:

- One upgrade package, which includes
 - HC(S)08 – 64K
 - ColdFire V1 – 128K



MCF51EM256 Poly-Phase Electricity Meter - Features

- Configurable to operate in:
 - Three phase, 4 wire (3 Φ -4W)
 - One phase, 1 wire (1 Φ -2W)
 - One phase, 1 wire (1 Φ -3W)
- Measurement & LCD display of:
 - US and European voltage specifications: full scale being 120V+/- 20%, 230V +/- 10%
 - US and European current specification: full scale being 100A US, 60A Europe
 - Phase wise RMS Voltage (Accuracy \pm 1% of full Scale)
 - Phase wise RMS Currents and neutral current (Accuracy \pm 1% of full scale)
 - Phase wise and Net Active Power (Accuracy \pm 1% of full Scale)
 - Phase wise and Net Reactive Power (Accuracy \pm 1% of full Scale)
 - Phase wise and Net Apparent Power (Accuracy \pm 1% of full Scale)
 - Phase wise and Net Power Factor (Accuracy \pm 0.1PF or better)
 - Line Frequency (Accuracy \pm 0.5Hz or better)
 - Tamper Count
 - Active Energy - Class 0.5 or better
 - Reactive energy - Class 2 or better
 - Apparent Energy - Class 2 or better
 - Display Date and Time of the Meter
 - Maximum Demand
- Operating frequency range 50Hz \pm 3Hz or 60Hz \pm 3Hz
- Measurement & storing of the following parameters:
 - Imported & Exported kWh
 - Imported kVAh (Leading and Lagging)
 - Exported kVAh(Leading and Lagging)
 - Imported & Exported kVAh
- Tamper Detection
- Optical Port Interface (IEC62056-21, ANSI C12.18)
- Serial port for calibration and diagnostics
- Navigation using 3 keys (UP, DOWN & ACK/RESET)
- Expansion port for AMR via SCI and SPI

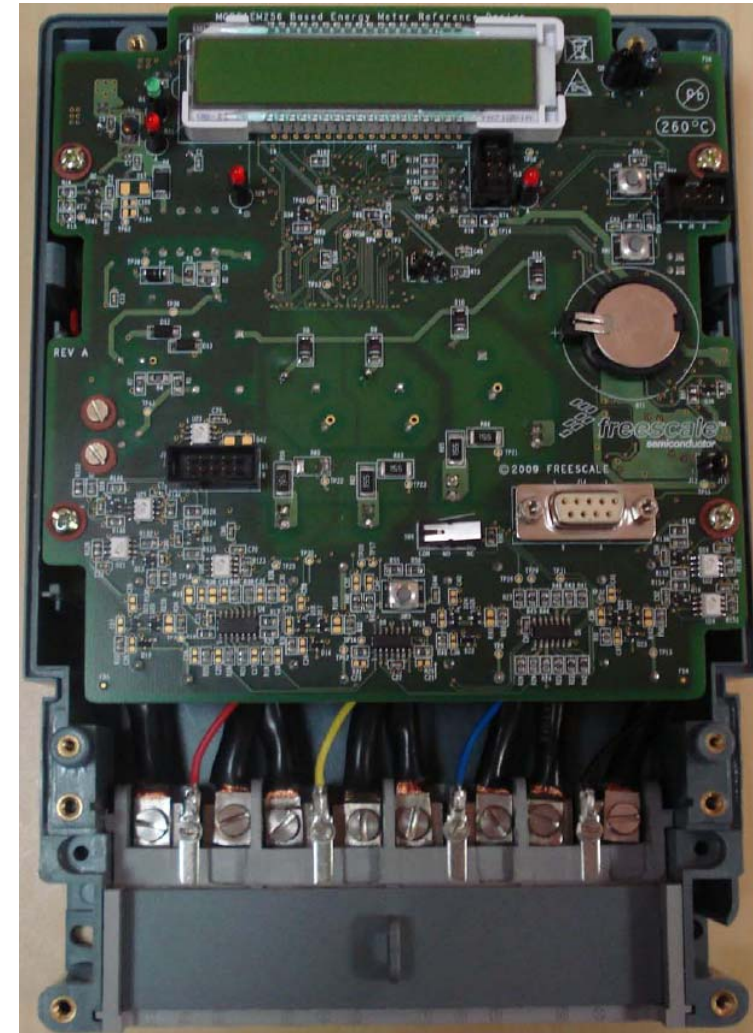

MCF51EM256 Poly-Phase Electricity Meter – Compliance with Standards

•The Electricity Meter Reference Design shall be compliant with the following standards:

•**IEC 62053-22** International Energy Metering Specification, class 0.5 (or better) for active energy

•**IEC 62053-23** International Energy Metering Specification, class 2 for reactive energy

•**ANSI C12.18** standards for optical interface

•**IEC 62056-21** International Energy Metering data exchange Specification

•**IEC 62053-22, IEC 62053-23, IEC 62052-11** Electro Static Discharge (ESD), tested per **IEC 61000-4**

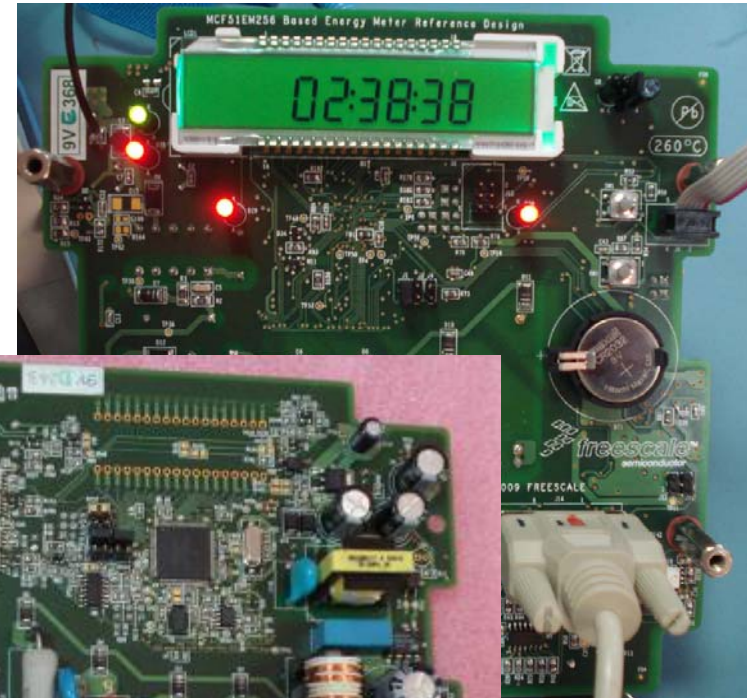

MCF51EM256 Poly-Phase Electricity Meter – Software Modules

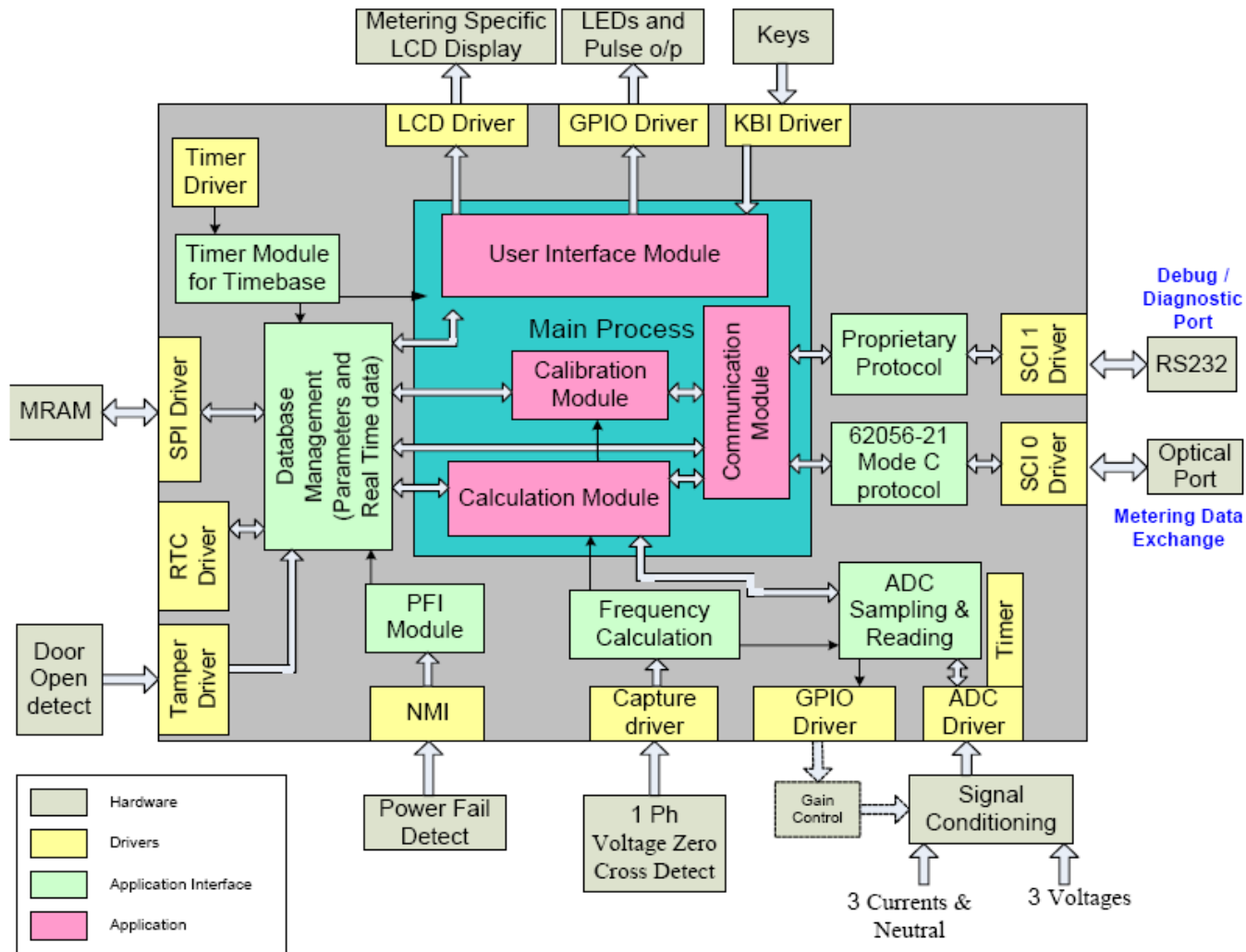

- Software modules:**
- User Interface
 - Calculation/Measurement
 - Communication
 - Database Management
 - Calibration
 - Main

MCF51EM256 Poly-Phase Electricity Meter - Availability

Documentation

- Reference Design Manual (PDF)
- Schematics (OrCAD)
- PCB design (Allegro)
- BOM (PDF)
- Enclosure data sheet (PDF)
- Wiring diagram (PDF)
- Pre-compliance test documents (PDF)
- Functional test documents (PDF)
- 110V configuration Technical Specification (PDF)
- 230V configuration Technical Specification (PDF)
- Individual component data sheets and further detailed documentation is available

Software

- Software source code as a CodeWarrior project, including APIs
- Compiled size of the entire software package is less than 128KB

Reference design system

- 110V configuration
- 230V configuration

Find the poly-phase reference design at www.freescale.com/metering

Summary

- **Standard products can help solve key customer problems for metering systems**
 - Maximize battery life → ultra low power 8bit & 32bit MCUs
 - Reliable readings → fast & accurate on-chip ADCs
 - Integration → memory, LCD ctrl, analog
 - Communication I/F → ZigBee, 802.15.4, and Ethernet
 - Apart of Standards → IEEE 802.15.4, ZigBee Alliance, PRIME (PLC), HomePlug ??
- **Commitment to the market with products and solutions that have characteristics important to the metering segment:**
 - Longevity of product available
 - Quality
- **Breadth of products spanning from RF to Sensors to MCUs to MPUs**
- **Mix & match IP allowing specific metering solutions**
- **Enablement**
 - Reduce product development cost
 - Improve time-to-market and time-in-market

Learn more about Freescale Solutions in Smart Metering – Come visit us at **Booth 502**



Making the World a Smarter Place.

