



Wafer and Die Form Factor of PCF8583

PCF8564A

Last Updated: Apr 11, 2024

The PCF8564A is a CMOS real-time clock and calendar optimized for low power consumption. A programmable clock output, interrupt output and voltage low detector are also provided. All addresses and data are transferred serially via a two-line bidirectional I²C-bus. Maximum bus speed is 400 kbit/s. The built-in word address register is incremented automatically after each written or read data byte.

Block diagram: PCF8564ACX9, PCF8564AU Block Diagram

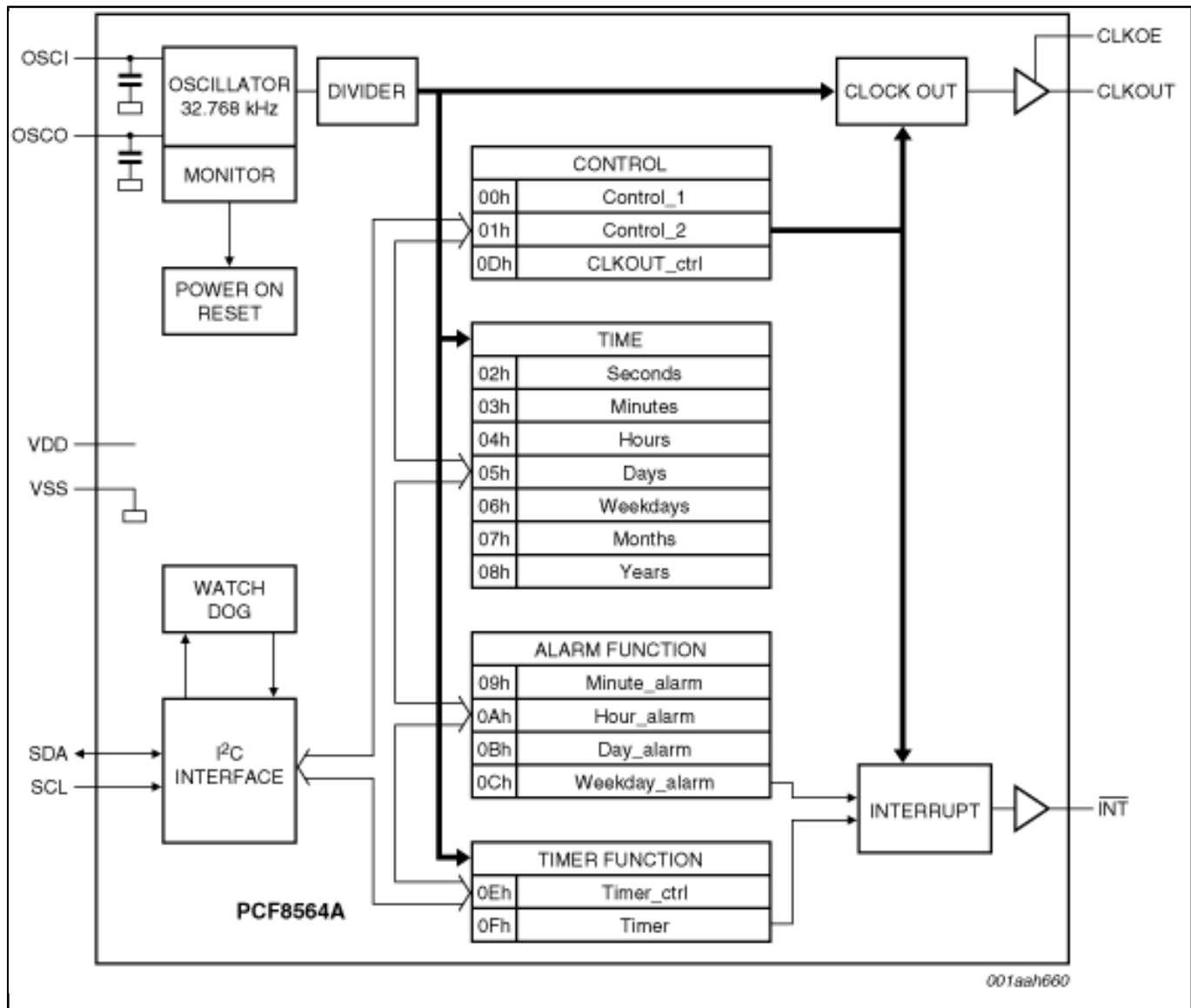

View additional information for [Wafer and Die Form Factor of PCF8583](#).

Note: The information on this document is subject to change without notice.

www.nxp.com

NXP and the NXP logo are trademarks of NXP B.V. All other product or service names are the property of their respective owners. The related technology may be protected by any or all of patents, copyrights, designs and trade secrets. All rights reserved. © 2024 NXP B.V.