



SIM Card Interface Level Translator and Supply Voltage LDO

NVT4555UK

Last Updated: Mar 15, 2024

The NVT4555 device is built for interfacing a SIM card with a single low-voltage host side interface. The NVT4555 contains an LDO that can deliver two different voltages, 1.8 V or 2.95 V from typical mobile phone battery voltages up to 5.25 V and three level translators to convert the data, RSTn and CLKn signals between a SIM card and a host microcontroller.

The NVT4555 contains one voltage select pin (CTRL) to select either 1.8 V or 2.95 V for SIM card power supply and one active HIGH enable pin (EN) to enable normal operation. The NVT4555 is compliant with all ETSI, IMT-2000 and ISO-7816 SIM/Smart card interface requirements.

SIM Card Interface Level Translator and Supply Voltage LDO Block Diagram

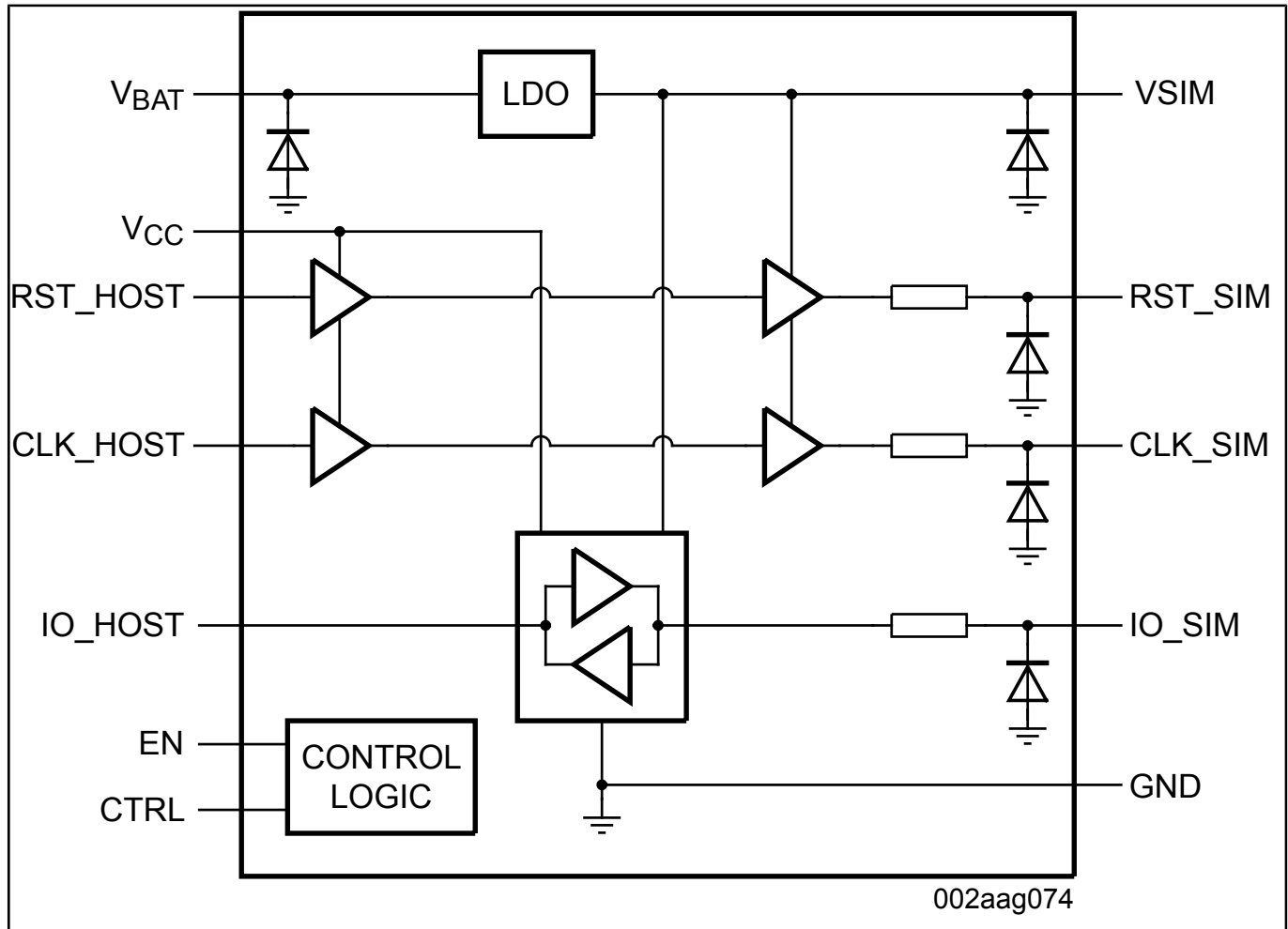

View additional information for [SIM Card Interface Level Translator and Supply Voltage LDO](#).

Note: The information on this document is subject to change without notice.

www.nxp.com

NXP and the NXP logo are trademarks of NXP B.V. All other product or service names are the property of their respective owners. The related technology may be protected by any or all of patents, copyrights, designs and trade secrets. All rights reserved. © 2024 NXP B.V.