



# Dual-Supply Translating Transceiver (Open-Drain, Auto-Direction Sensing)

## NTSX2102

Last Updated: Mar 15, 2024

The NTSX2102 is a 2-bit, dual supply translating transceiver with auto direction sensing, that enables bidirectional voltage level translation. It features two 2-bit input-output ports (An and Bn), one output enable input (OE) and two supply pins (VCC(A) and VCC(B)). Both supplies can be supplied at any voltage between 1.65 V and 5.5 V. This flexibility makes the device suitable for translating between any of the voltage nodes (1.8 V, 2.5 V, 3.3 V and 5.0 V). Pins An and OE are referenced to VCC(A) and pins Bn are referenced to VCC(B). A LOW level at pin OE causes the outputs to assume a high-impedance OFF-state. This device is fully specified for partial power-down applications using IOFF. The IOFF circuitry disables the output, preventing the damaging backflow current through the device when it is powered down.

# NTSX2102 Block Diagram Block Diagram

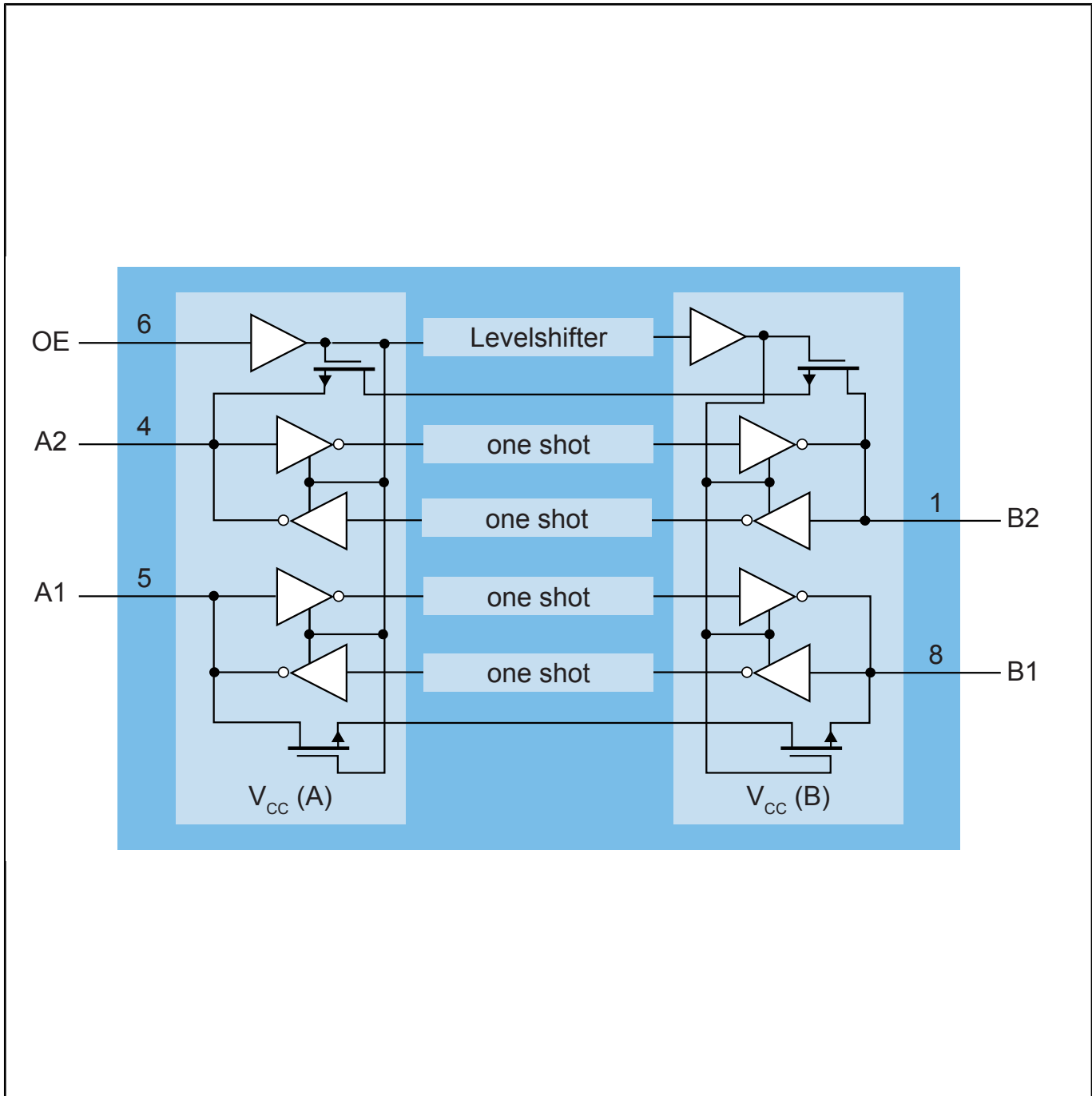

View additional information for [Dual-Supply Translating Transceiver \(Open-Drain, Auto-Direction Sensing\)](#).

**Note:** The information on this document is subject to change without notice.

**[www.nxp.com](http://www.nxp.com)**

NXP and the NXP logo are trademarks of NXP B.V. All other product or service names are the property of their respective owners. The related technology may be protected by any or all of patents, copyrights, designs and trade secrets. All rights reserved. © 2024 NXP B.V.