



32-bit MCU for Automotive Powertrain Applications

MPC5566

Last Updated: Jul 3, 2023

Designed for engine management, the NXP® MPC5566 embedded controller provides developers with a cost-effective medium to support more sophisticated, memory-intensive timing and control functionality.

- Helps increase fuel efficiency and improved emissions
- Allows more advanced engine control systems to be deployed
- Enables easy migration to next-generation 3 MB flash-embedded controllers
- Offers system performance of up to five times that of its MPC500 predecessors
- Ideal for any application that requires complex, real-time control
- Qualifies for the harshest automotive environments
- Pin-and code-compatible with other MPC5500 family MCUs

MPC5566 Block Diagram Block Diagram

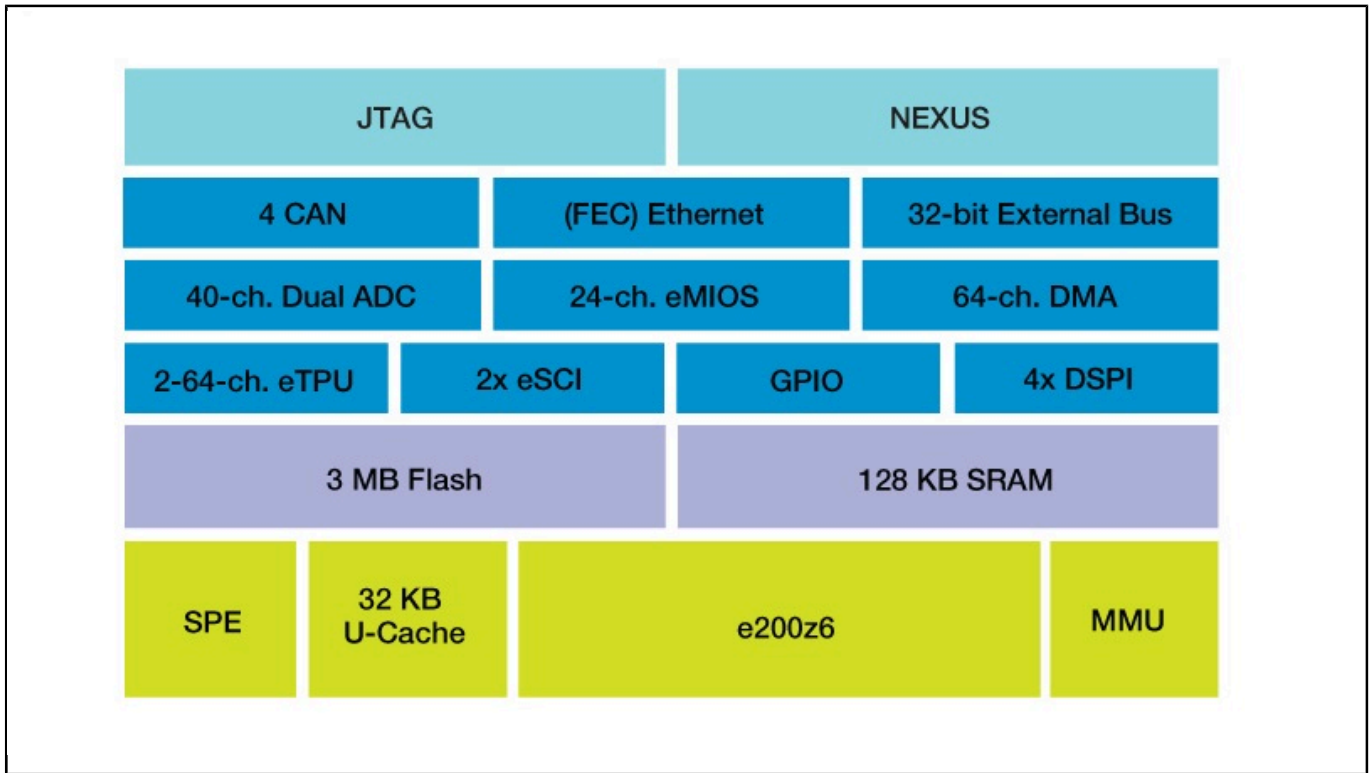

View additional information for [32-bit MCU for Automotive Powertrain Applications](#).

Note: The information on this document is subject to change without notice.

www.nxp.com

NXP and the NXP logo are trademarks of NXP B.V. All other product or service names are the property of their respective owners. The related technology may be protected by any or all of patents, copyrights, designs and trade secrets. All rights reserved. © 2024 NXP B.V.