

TWR-SB0800-36EVB tower system platform

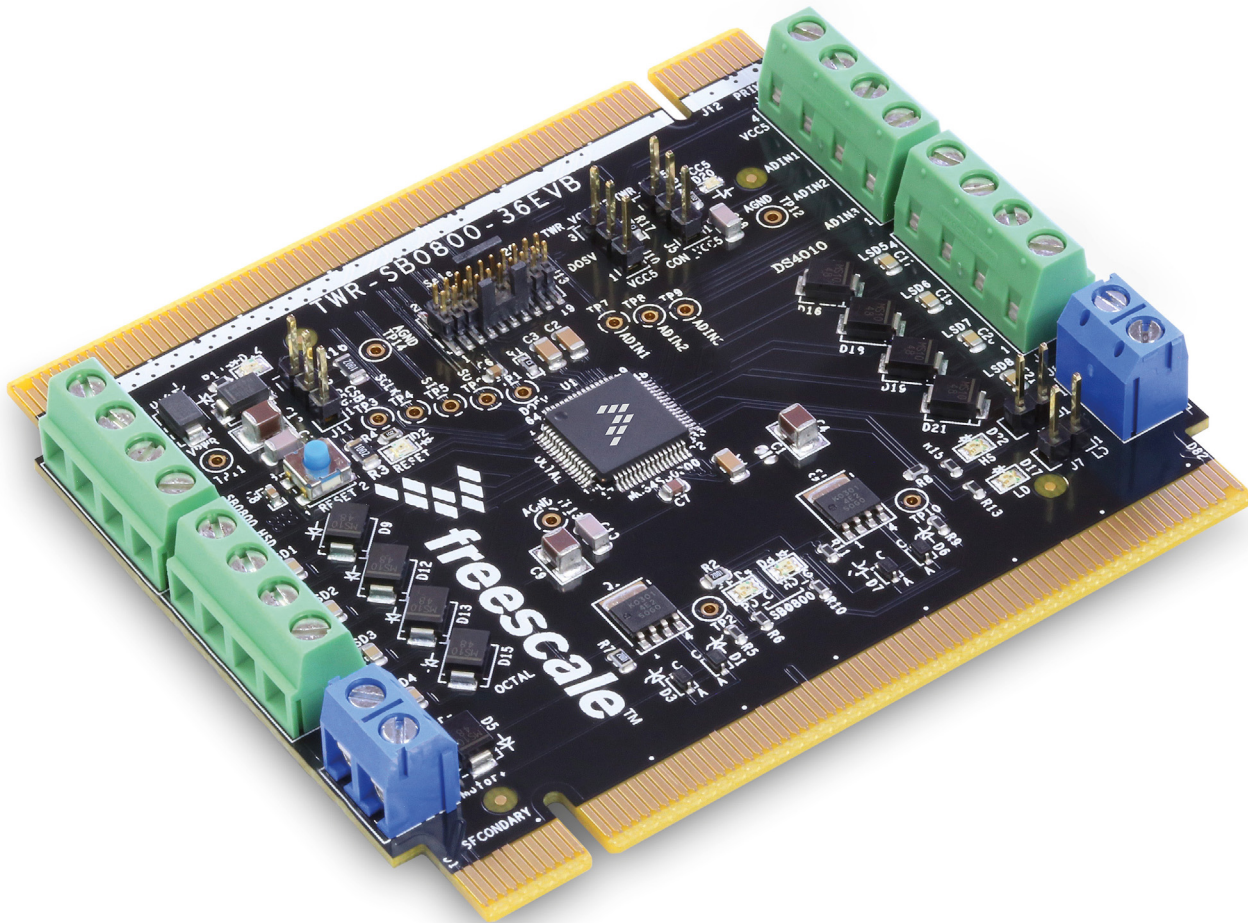

Figure 1. TWR-SB0800-36EVB

Contents

1	Important notice	3
2	Getting started	4
3	Understanding the tower system modular development board platform	5
4	Getting to know the hardware	7
5	Setting up the hardware	14
6	Schematic	16
7	Board layout	19
8	Board bill of materials	20
9	References	22
10	Revision history	23

1 Important notice

NXP provides the enclosed product(s) under the following conditions:

This evaluation kit is intended for use of ENGINEERING DEVELOPMENT OR EVALUATION PURPOSES ONLY. It is provided as a sample IC pre-soldered to a printed circuit board to make it easier to access inputs, outputs, and supply terminals. This evaluation board may be used with any development system or other source of I/O signals by simply connecting it to the host MCU or computer board via off-the-shelf cables. This evaluation board is not a Reference Design and is not intended to represent a final design recommendation for any particular application. Final device in an application will be heavily dependent on proper printed circuit board layout and heat sinking design as well as attention to supply filtering, transient suppression, and I/O signal quality.

The goods provided may not be complete in terms of required design, marketing, and or manufacturing related protective considerations, including product safety measures typically found in the end product incorporating the goods. Due to the open construction of the product, it is the user's responsibility to take any and all appropriate precautions with regard to electrostatic discharge. In order to minimize risks associated with the customers applications, adequate design and operating safeguards must be provided by the customer to minimize inherent or procedural hazards. For any safety concerns, contact NXP sales and technical support services.

Should this evaluation kit not meet the specifications indicated in the kit, it may be returned within 30 days from the date of delivery and will be replaced by a new kit.

NXP reserves the right to make changes without further notice to any products herein. NXP makes no warranty, representation or guarantee regarding the suitability of its products for any particular purpose, nor does NXP assume any liability arising out of the application or use of any product or circuit, and specifically disclaims any and all liability, including without limitation consequential or incidental damages. "Typical" parameters can and do vary in different applications and actual performance may vary over time. All operating parameters, including "Typical", must be validated for each customer application by customer's technical experts.

NXP does not convey any license under its patent rights nor the rights of others. NXP products are not designed, intended, or authorized for use as components in systems intended for surgical implant into the body, or other applications intended to support or sustain life, or for any other application in which the failure of the NXP product could create a situation where personal injury or death may occur.

Should the Buyer purchase or use NXP products for any such unintended or unauthorized application, the Buyer shall indemnify and hold NXP and its officers, employees, subsidiaries, affiliates, and distributors harmless against all claims, costs, damages, and expenses, and reasonable attorney fees arising out of, directly or indirectly, any claim of personal injury or death associated with such unintended or unauthorized use, even if such claim alleges NXP was negligent regarding the design or manufacture of the part. NXP™ and the NXP logo are trademarks of NXP Semiconductors. All other product or service names are the property of their respective owners. © 2016 NXP B.V.

2 Getting started

2.1 Kit contents/packing list

The TWR-SB0800-36EVB contents include:

- TWR-SB0800-36EVB tower board
- Plug-in connectors
- Warranty card

2.2 Jump start

NXP's analog product development boards help to easily evaluate NXP products. These tools support analog mixed signal and power solutions including monolithic ICs using proven high-volume SMARTMOS mixed signal technology, and system-in-package devices utilizing power, SMARTMOS and MCU dies. NXP products enable longer battery life, smaller form factor, component count reduction, ease of design, lower system cost, and improved performance in powering state of the art systems.

- Go to www.nxp.com/TWR-SB0800-36EVB
- Review your Tool Summary Page
- Look for



Jump Start Your Design

- Download the documents, software and other resources

Once the files are downloaded, review the user guide in the bundle. The user guide includes setup instructions, BOM, and schematics. Jump start bundles are available on each tool summary page with the most relevant and current information. The information includes everything needed for design.

2.3 Required equipment and software

To use this kit, you need:

- Power supply 6.0 V to 36 V with current limit set initially to 2.5 A to 9.0 A
- Oscilloscope (preferably 4-channel) with current probe(s)
- Digital multimeter
- Typical loads: (DC motor, valve)
- TWR-KL25Z48M, K20D72M, KV31F120M or other Tower boards (check compatibility)
- Kinetis Design Studio or compatible CodeWarrior for MCUs (Eclipse IDE). For information on getting started with CodeWarrior, see the MC34Valve Controller Processor Expert Component User Guide.

2.4 System requirements

The kit requires the following to function properly with the software:

- USB-enabled PC with Windows® XP or higher

3 Understanding the tower system modular development board platform

NXP's Tower System peripheral module is designed to be combined and used with other Tower System modules. The Tower System is a modular development platform for 8-, 16-, and 32-bit MCUs and MPUs enabling advanced development through rapid prototyping. Featuring more than fifty development boards or modules, the Tower System provides designers with building blocks for entry-level to advanced MCU development. [Figure 2](#) shows a Tower System platform with the TWR-SB0800-36EVB configured with another Tower System module, the TWR-KL25Z48M board.

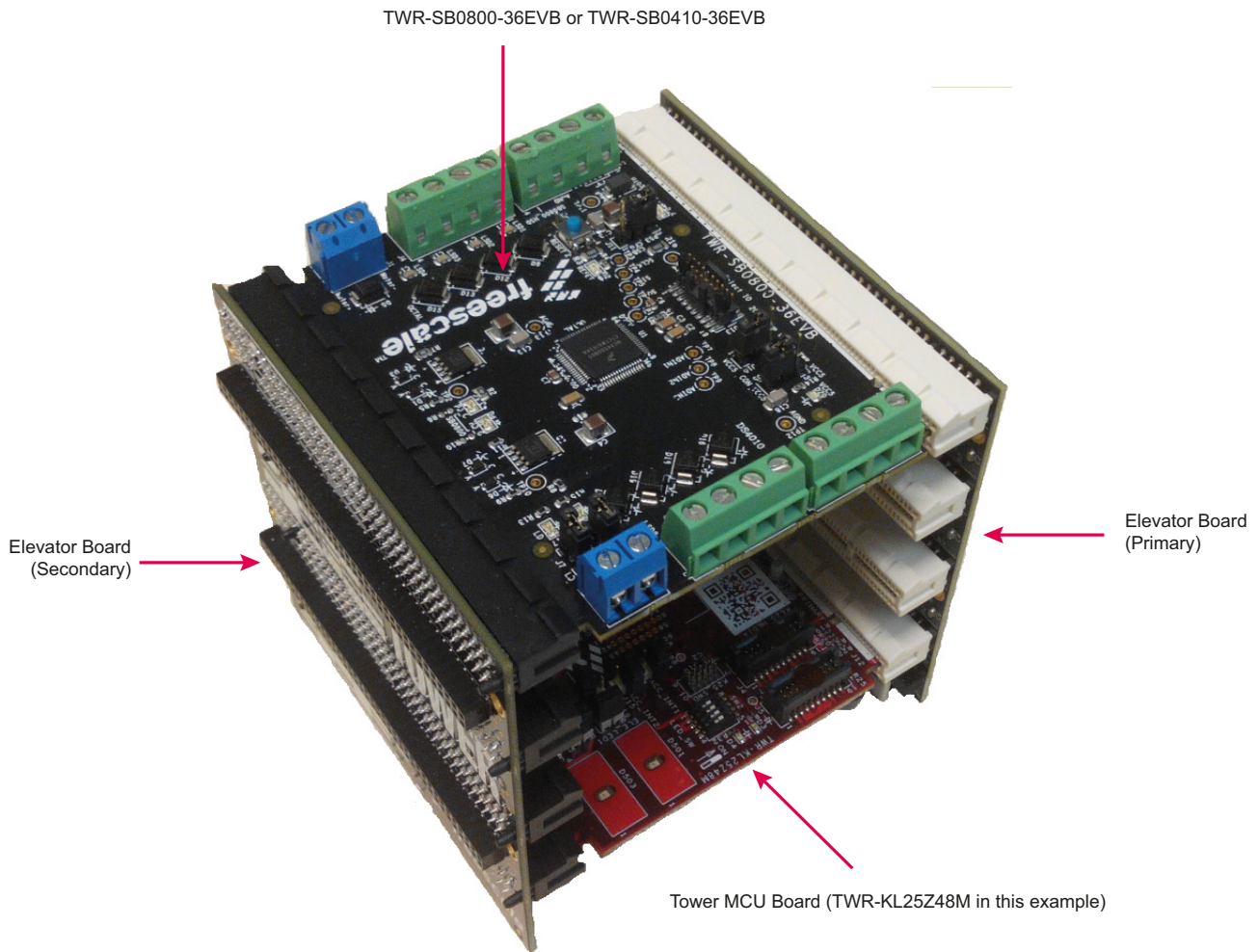

Figure 2. TWR-SB0800-36EVB on tower system

3.1 Block diagram

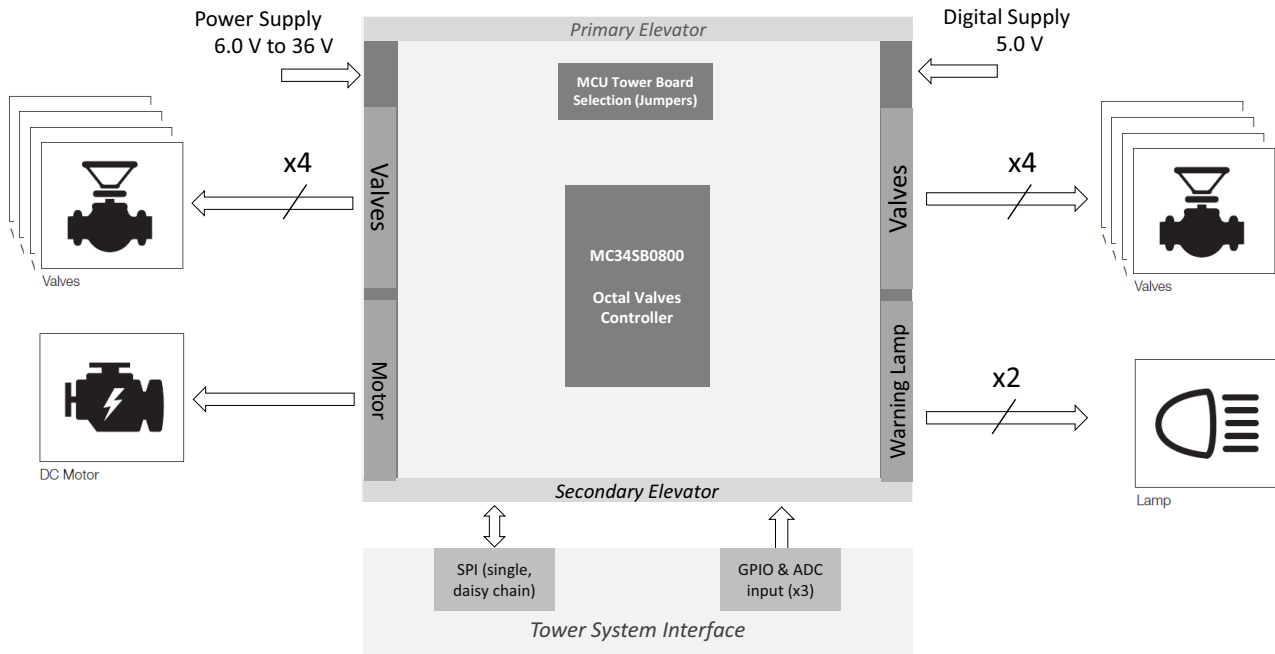

Figure 3. Block diagram

Note:

Warning lamp application is proposed as an example in [Figure 3](#). The lamp is connected to the low-side driver (general purpose).

4 Getting to know the hardware

4.1 Board overview

The TWR-SB0800-36EVB is a tower peripheral module that exercises valve control functions on SoC products based on the Tower System. The Tower System acts as a debug and communication port for the PC being used to debug/download programs from the Kinetis Design Studio/CodeWarrior system.

4.2 Board features

The board features are as follows:

- Valve controller with embedded safety features: MC34SB0800
- Four current regulated valve driver outputs (maximum current: 2.25 A; maximum frequency 5.0 kHz)
- Four PWM valve driver outputs (maximum current 5.0 A; maximum frequency 5.0 kHz)
- High-side pre-driver Safe Switch
- High-side pre-driver motor control (maximum frequency 500 Hz)
- Embedded Safety Supervision
- Simplified MCU connections
- SPI daisy chain communication with other TWR-SB0800-36EVB or TWR-0410-36EVB boards (daisy chain mode jumper selectable)
- Single SPI communication support
- On-board LED ON/OFF indicators for each high-side and low-side (general purpose) channel
- Three 10-bit ADC inputs

4.3 Device features

This tower system features the following NXP product:

Table 1. Device features

Device	Description	Features
MC34SB0800	Octal Valve Controller System on Chip	<p>Control features</p> <ul style="list-style-type: none"> • Operating voltage up to 36 V • Four low-side drivers regulate up to 2.25 A • $\pm 2.0\%$ precision reachable with calibration • Four low-side drivers PWM up to 5 kHz with a maximum current capability up to 5.0 A • Integrated low-side drivers to save PCB space • ADC monitoring of external or internal signals to enhance the control unit safety level • Single SPI device control • MCU sent only when current or duty-cycle is targeted through the SPI • MCU does not need to generate PWM signals at high frequency <p>Safety features</p> <ul style="list-style-type: none"> • Safe MOSFET turns off valves and motor when problems occur • Watchdog feature • Under-voltage, over-voltage clock fail detection • Open load, short circuit, over-temperature detection on each low side • V_{DS} monitoring of each low-side driver in real time • Over-current and over-temperature detection on the high-side pre-driver

4.4 Board description

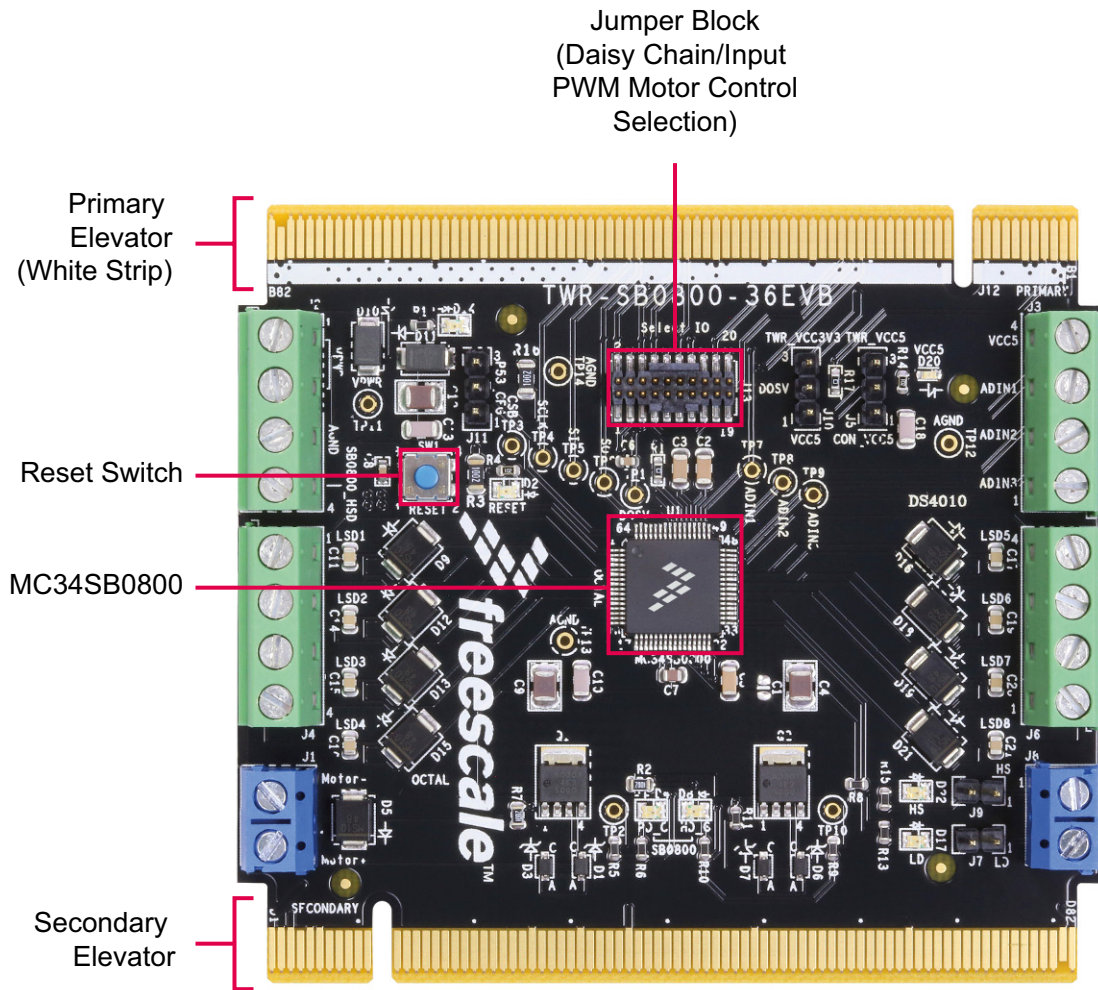

Figure 4. Board overview

Table 2. Board description

Name	Description
Reset switch	Resets the MC34SB0800 device
Primary elevator	Edge connector to primary elevator board (white stripe to white connector on elevator board)
Secondary Elevator	Edge connector to secondary elevator board
Daisy chain/input PWM motor control	Jumper block for selection of daisy chain or input PWM motor control
MC34SB0800	Octal Valve Controller System on Chip

4.4.1 LED display

The following LEDs are provided as visual output devices for the TWR-SB0800-36EVB:

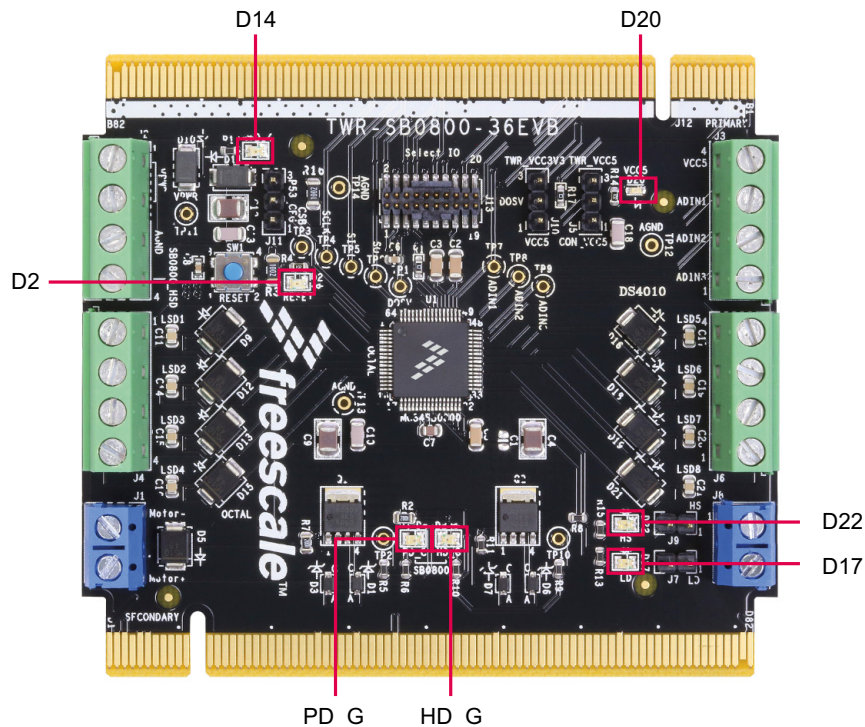

Figure 5. LED locations

Table 3. LEDs

LED ID	Description
D2	Indicates when the MC34SB0800 is in Reset or Safe /Normal Mode (Blinking = Reset Mode; ON = Safe/Normal Mode)
D14	Indicates when power is being supplied to the MC34SB0800
D17	Indicates when the low-side general purpose driver is in the ON state
D20	Indicates when 5.0 V is being supplied to the VCC5 input
D22	Indicates when the high-side general purpose driver is in the ON state
HD_G	Not connected
PD_G	Not connected

4.4.2 Test point definitions

The following tests point are provided for signal analysis of the MC34SB0800 device.

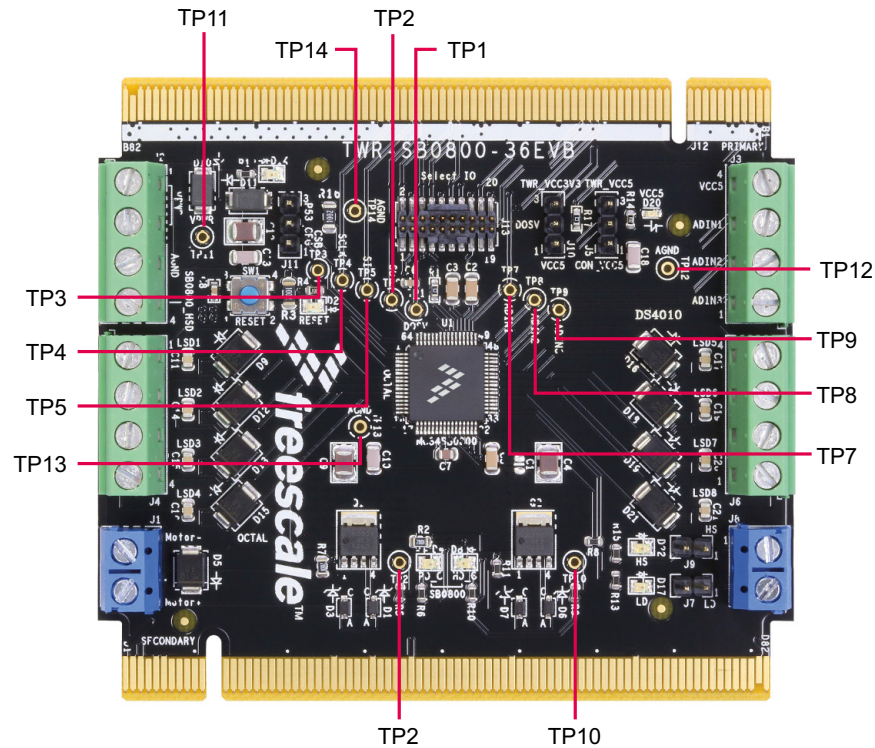

Figure 6. Test point locations

Table 4. Test points

Schematic label	Description
TP1	DOSV (digital output) signal
TP2	DC motor gate driver signal
TP3	SPI/Chip Select signal
TP4	SPI clock signal
TP5	SPI MOSI signal
TP6	SPI MISO signal
TP7	ADN1 signal (10-bit ADC)
TP8	ADN2 signal (10-bit ADC)
TP9	ADN3 signal (10-bit ADC)
TP10	High-side pre-driver Safe Switch gate signal
TP11	VPWR signal
TP12	AGND signal
TP13	AGND signal
TP14	AGND signal

4.4.3 Connectors

Input/output connectors provide the following signals:

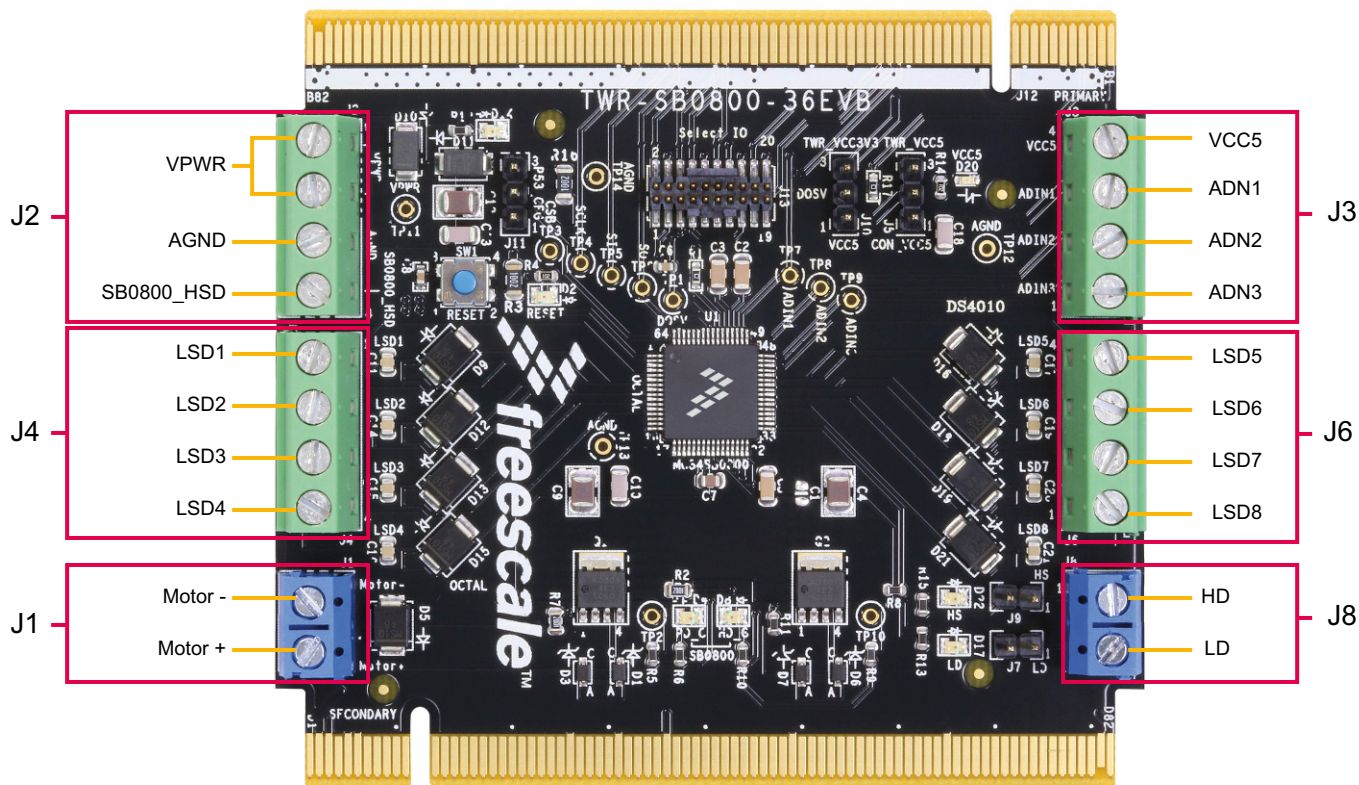

Figure 7. Connector locations

Table 5. Connectors

Name	Description
J2	VPWR - Power supply inputs for the MC34SB0800 (6.0 V to 36 V)
J2	AGND - Ground input for the MC34SB0800
J2	SB0800_HSD - High-side Safe Switch output for the MC34SB0800
J4	LSD1 - Regulated valve driver output 1 for the MC34SB0800 (2.25 A maximum, 5.0 kHz maximum)
J4	LSD2 - Regulated valve driver output 2 for the MC34SB0800 (2.25 A maximum, 5.0 kHz maximum)
J4	LSD3 - Regulated valve driver output 3 for the MC34SB0800 (2.25 A maximum, 5.0 kHz maximum)
J4	LSD4 - Regulated valve driver output 4 for the MC34SB0800 (2.25 A maximum, 5.0 kHz maximum)
J3	VCC5 - 5.0 V external digital input to the MC34SB0800 (not required if J5, J10 and J11 select the 5.0 V tower supply)
J3	ADIN1 - 10-bit ADC input 1 to the MC34SB0800 (for safety and general purpose external monitoring)
J3	ADIN2 - 10-bit ADC input 2 to the MC34SB0800 (for safety and general purpose external monitoring)
J3	ADIN3 - 10-bit ADC input 3 to the MC34SB0800 (for safety and general purpose external monitoring)
J6	LSD5 - PWM valve driver output 5 for the MC34SB0800 (5.0 A maximum; 5.0 kHz maximum)

Table 5. Connectors (continued)

Name	Description
J6	LSD6 - PWM valve driver output 6 for the MC34SB0800 (5.0 A maximum; 5.0 kHz maximum)
J6	LSD7 - PWM valve driver output 7 for the MC34SB0800 (5.0 A maximum; 5.0 kHz maximum)
J6	LSD8 - PWM valve driver output 8 for the MC34SB0800 (5.0 A maximum; 5.0 kHz maximum)
J8	HD - High-side general purpose driver output for MC34SB0800 with LED indicator
J8	LD - Low-side general purpose driver output for MC34SB0800 with LED indicator

4.4.4 Jumper definitions

Figure 8 and Table 6 define the jumper positions and explains their functions. (The default settings are shown in bold.)

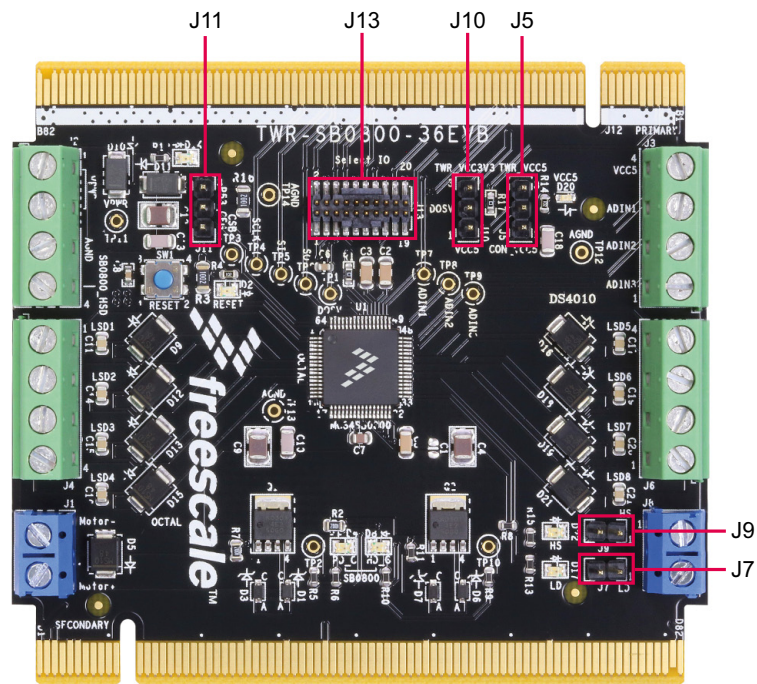

Figure 8. Jumper locations

Table 6. Jumpers

Jumper	Description	Setting	Connection
J5	Selects between Tower 5.0 V supply and external 5.0 V supply	1–2	External 5.0 V supply
		2–3	Tower 5.0 V supply
J7	Connect/Disconnect LED as the general purpose low-side driver load	1–2	LED connected
		Not connected	LED disconnected
J9	Connect/Disconnect LED as the general purpose high-side driver load	1–2	LED connected
		Not connected	LED disconnected
J10	Selects between digital voltage level of 5.0 V and 3.3 V	1–2	5.0 V digital voltage level
		2–3	3.3 V digital voltage level
J11	Selects between digital under voltage level of 5.0 V and 3.3 V	1–2	5.0 V digital under-voltage level
		2–3	3.3 V digital under-voltage level
J13	Selects compatibility settings when using additional tower boards	Multiple	See Section 5.2 "Tower board settings"

5 Setting up the hardware

5.1 Configuring the hardware

Table 7 shows jumper settings for various MCU Tower Boards. Figure 9 shows a typical configuration using the TWR-KL25Z48M and the jumper settings outlined in red in Table 7.

Table 7. MCU tower board TWR-KL25Z48M jumper settings

	TWR-KL25Z48M	TWR-KV31F120M	TWR-KV10Z32	TWR-K64F120M	TWR-K20	TWR-K22F120	TWR-K70
RSTB	GPIO1	GPIO1	GPIO1	GPIO1	GPIO8	GPIO1	GPIO2
CSB	GPIO2	GPIO2	GPIO2	GPIO2	GPIO9	GPIO2	GPIO3
PDI	PWM4	PWM4	PWM4	PWM4	PWM4	PWM0	PWM4

In this example, J5 is set to connect to an external 5.0 V power supply, J10 selects 3.3 V as the digital voltage level and J11 sets the digital under-voltage level at 3.3 V. J7 and J9 connect the LED low-side and high-side driver loads.

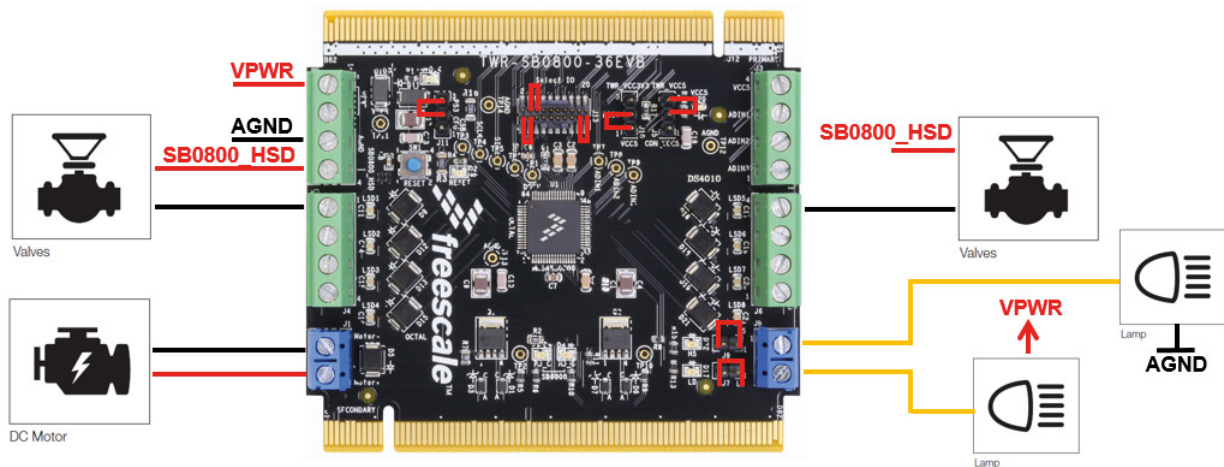

Figure 9. Configuration example

5.2 Tower board settings

A jumper block (J13) on the TWR-SB0800-36EVB provides a means of configuring the board for use with additional MCUs. The J13 jumper settings define the routing of all SPI signals, the reset signal from the MCU and the PWM motor control signal. In addition, jumper J10 allows you to select between either 3.3 V or 5.0 V depending on the requirement of the MCU being used.

Make sure that you set jumper J10 to the proper voltage level and that you set the jumpers on J13 to appropriate positions for the selected MCU. Check the schematic of each tower elevator board to assure that all signals are correctly connected.

Figure 10 shows the selection options on the TWR-SB0800-36EVB.

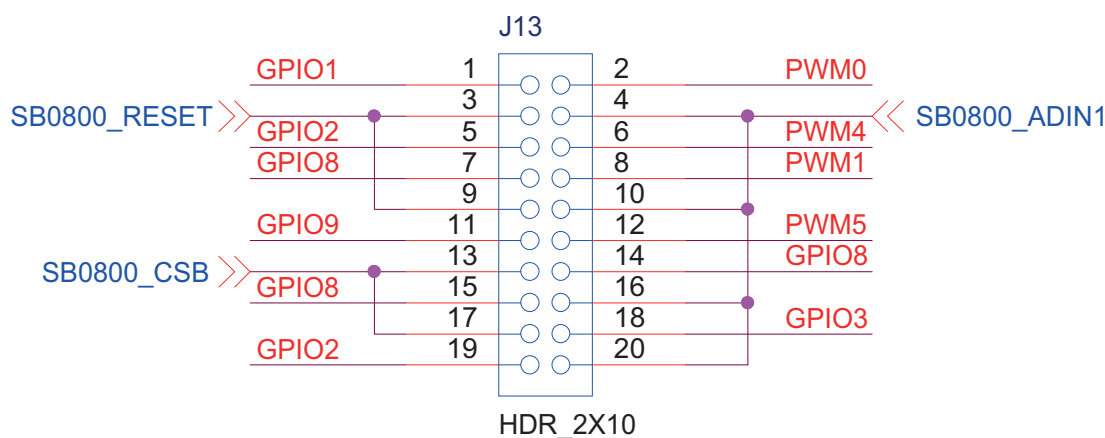

Figure 10. Jumpers for IO selection

Blue text indicates signals coming from the MC34SB0800 of the TWR-SB0800-36EVB.

Red text indicates signals coming from the tower elevator board (Primary and Secondary).

Table 8 shows J13 jumper settings for compatible tower boards. These settings are important because the **Reset** (RSTB) and **Chip Select** (CSB) signals must be routed to MCU IO header positions that can handle such signals. Note that the **ADIN1** pin can be used either to directly control the **Pump Motor Pre-Driver** or to measure external voltage.

Table 8. Jumper settings for compatible tower boards

	TWR-KL25Z48M	TWR-KV31F120M	TWR-KV10Z32	TWR-K64F120M	TWR-K20	TWR-K22F120	TWR-K70
RSTB	GPIO1	GPIO1	GPIO1	GPIO1	GPIO8	GPIO1	GPIO2
CSB	GPIO2	GPIO2	GPIO2	GPIO2	GPIO9	GPIO2	GPIO3
ADIN1	PWM4	PWM4	PWM4	PWM4	PWM4	PWM0	PWM4

5.3 Step-by-step instructions for setting up the hardware

To perform the demonstration examples, the following connections and setup must be performed:

1. Mount the TWR-SB0800-36EVB and TWR-KL25Z48M board firmly to the tower elevator connectors. Notice that, on the board, the edge connector with the white stripe must be matched with the white connector on the primary elevator module.
2. Connect the positive wire from the power supply to the positive "VPWR" terminal on connector J2 of the TWR-SB0800-36EVB. Connect the negative wire from the power supply to the "AGND" terminal on connector J2.
3. Check to assure that all jumpers are in the default position on the TWR-SB0800-36EVB and the TWR-KL25Z48M board (refer to the tower MCU board User Guide).
4. Attach a USB mini-cable between the PC and the USB mini-plug connector on the TWR-KL25Z48M board. This cable serves as the VCC5 supply and the communication link between the tower boards platform and the PC.

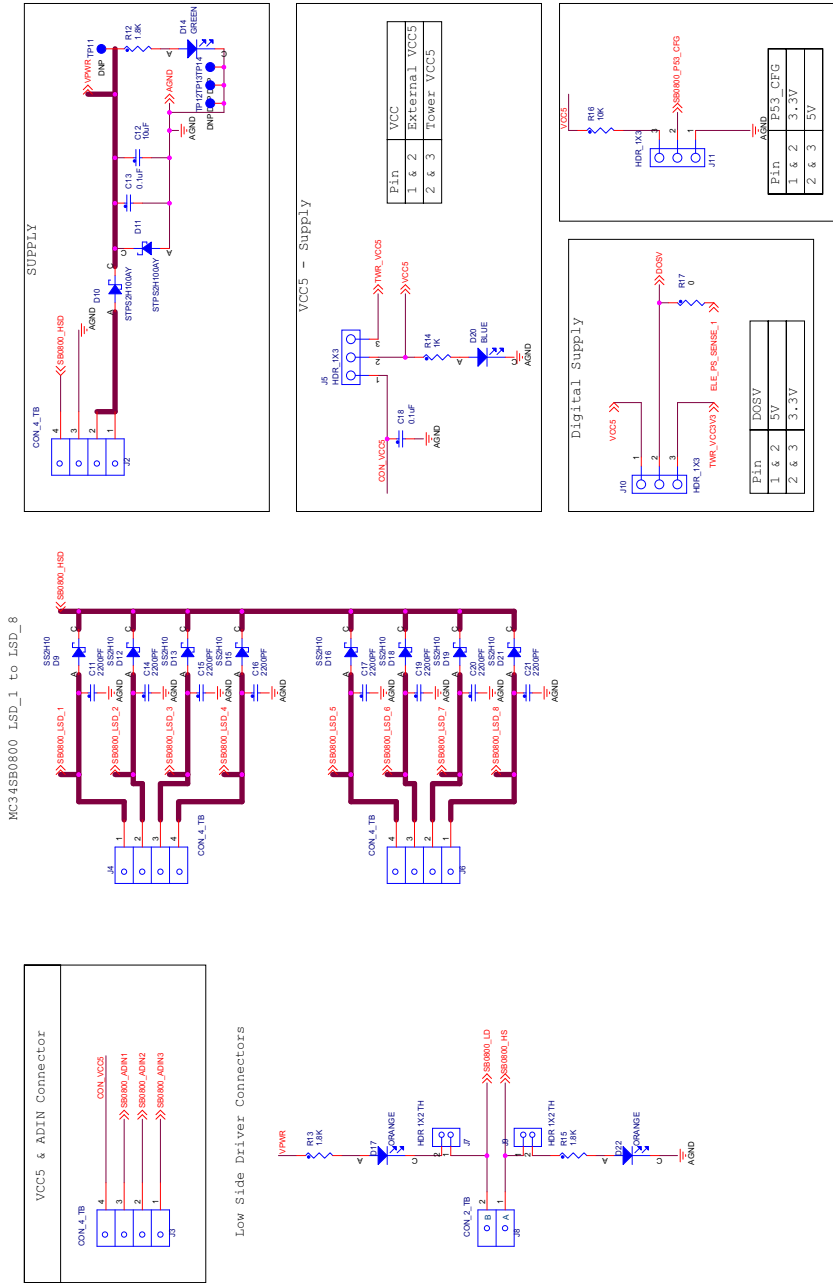

Figure 12. Schematic part 2

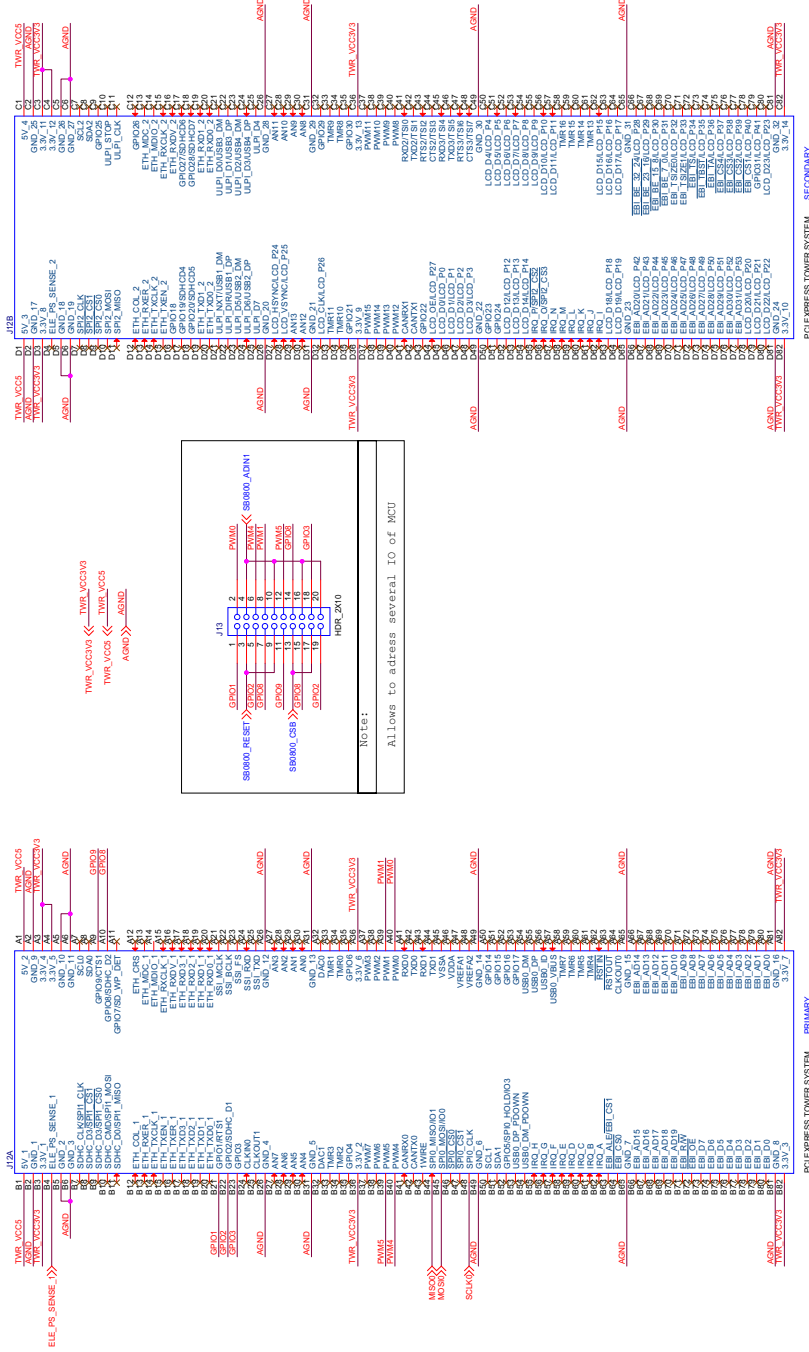
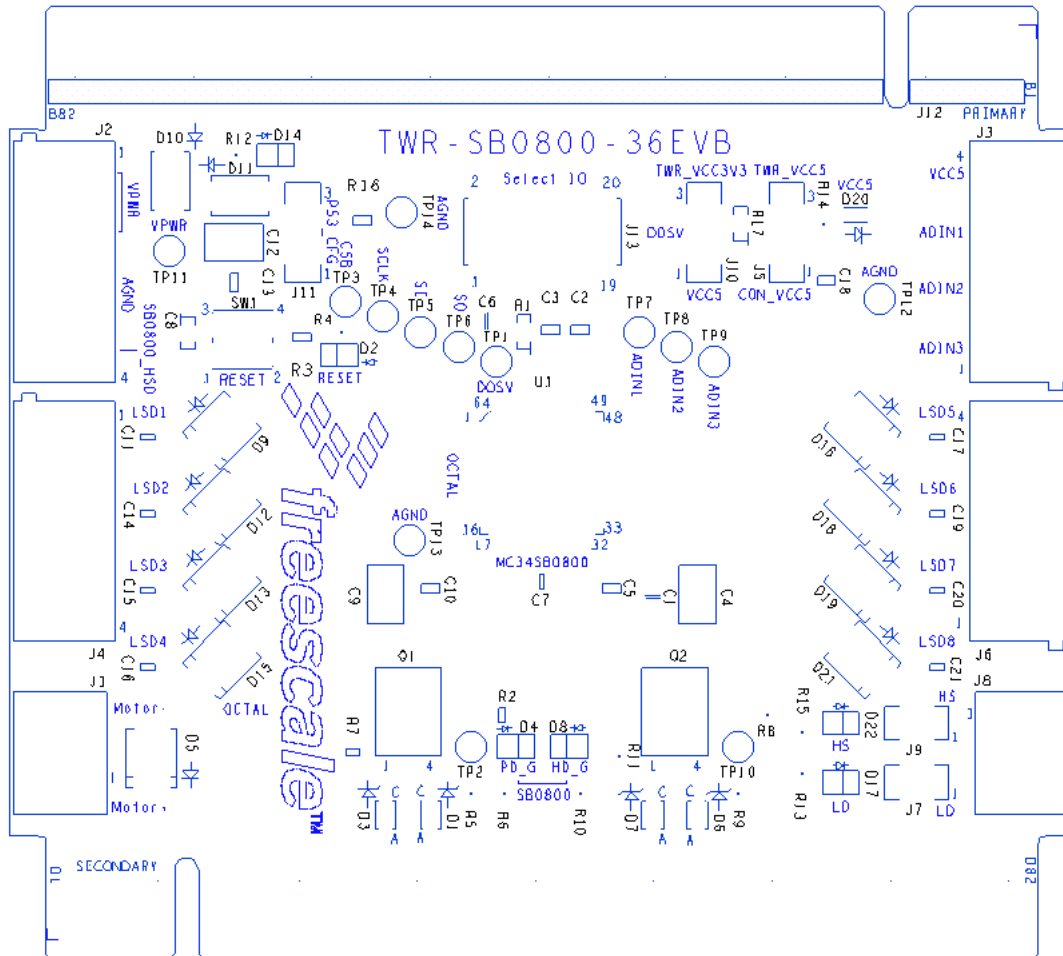

Figure 13. Schematic part 3

7 Board layout

7.1 Silkscreen



8 Board bill of materials

Table 9. Bill of materials⁽¹⁾

Item	Qty	Schematic label	Value	Description	Part Number	Assy Opt
NXP components						
1	1	U1		IC VALVES AND PUMP CONTROLLER 3.3 V / 5.0 V LQFP64	MC34SB0800AE	
Active components						
2	2	Q1, Q2		TRAN NMOS PWR 60 A 30 V LFPK5	RJK0301DPB-00-J0	Use reference PSMN1R8-40YLC
Diodes						
3	4	D1, D3, D6, D7		DIODE ZNR 5 MA 15V 0.2 W AEC-Q101 SOD-323	GDZ15B-E3-08	
4	2	D2, D14	GREEN	LED GRN SGL 30 MA SMT 0805	LTST-C171KGKT	
5	2	D4, D8	ORANGE	LED OR SGL 30 MA 0805 SMT	APHCM2012SECK-F01	(2)
6	9	D5, D9, D12, D13, D15, D16, D18, D19, D21	SS2H10	DIODE SCH RECT 2 A 100 V DO-214AA	SS2H10-E3/52T	
7	2	D10, D11		DIODE PWR RECT SCH 2 A 100 V AEC-Q101 SMA	STPS2H100AY	
8	2	D17, D22	ORANGE	LED OR SGL 30 MA 0805 SMT	APHCM2012SECK-F01	
9	1	D20	BLUE	LED BLUE SGL 30 mA 2.6 V 0603	UT-692NB	
Capacitors						
10	1	C1	0.1 μ F	CAP CER 0.1 μ F 50 V 10% X7R 0603	GRM188R71H104KA93D	(2)
11	3	C2, C3, C5	0.22 μ F	CAP CER 0.22 μ F 50 V 5% X7R 1206	C1206C224J5RACTU	
12	3	C4, C9, C12	10 μ F	CAP CER 10 μ F 50 V 10% X7S AEC-Q200 1210	GCM32EC71H106KA03	
13	1	C6	1 μ F	CAP CER 1 μ F 25 V 10% X7R 0603	0603X105K250SNT	
14	1	C7	0.22 μ F	CAP CER 0.22 μ F 100 V 20% X7S 0805	C2012X7S2A224M/SOFT	
15	1	C8	1000 pF	CAP CER 1000 pF 25 V 5% C0G CC0603	C0603C102J3GAC	Replace by a strap or 0 ohm resistor
16	3	C10, C13, C18	0.1 μ F	CAP CER 0.1 μ F 50 V 5% C0G AEC-Q200 1206	CGA5L2C0G1H104J160 AA	
17	8	C11, C14, C15, C16, C17, C19, C20, C21	2200 pF	CAP CER 2200 pF 50 V 5% X7R 0805	MCCE222J2NRTF	
Resistors						
18	1	R1	0 Ω	RES MF ZERO Ω 1/10 W -- AEC-Q200 0603	CRCW06030000Z0EA	
19	2	R2, R7	2 Ω	RES MF 2 Ω 1/8 W 1% 0805	CR0805-FX-2001ELF	
20	2	R3, R16	10 Ω	RES MF 10 Ω 1/4 W 5% 1206	CR1206JW103ELF	
21	2	R4, R14	1 Ω	RES MF 1 Ω 1/10 W 0.5% 0603	MCT06030C1001DP500	
22	4	R5, R8, R9, R11	100 Ω	RES MF 100 Ω 1/10 W 1% AEC-Q200 0603	CRCW0603100RFKEA	
23	2	R6, R10	1.8 Ω	RES MF 1.8 Ω 1/10 W 5% 0603	WR06X182JTL	(2)
24	3	R12, R13, R15	1.8 Ω	RES MF 1.8 Ω 1/10 W 5% 0603	WR06X182JTL	
25	1	R17	0 Ω	RES MF ZERO Ω 1/10W -- AEC-Q200 0603	CRCW06030000Z0EA	(2)
Switches, connectors, jumpers and test points						
26	2	J1, J8	CON_2_TB	CON 1X2 TB TH 5 MM SP 394H SN	CTB5000/2	
27	4	J2, J3, J4, J6	CON_4_TB	CON 1X4 TB TH 5 MM SP 394H SN	282836-4	
28	2	J5, J11	HDR_1X3	HDR 1X3 TH 100 MIL SP 374H AU	826629-3	Place jumper on pin 2–3
29	2	J7, J9	HDR 1X2 TH	HDR 1X2 TH 100 MIL SP 339H AU 98L	TSW-102-07-G-S	Place jumper on pin 1–2
30	1	J10	HDR_1X3	HDR 1X3 TH 100 MIL SP 374H AU	826629-3	Place jumper on pin 1–2
31	1	J12	PCI EXPRESS TOWER SYSTEM	CON DUAL 2X82 Edge PCI Express SMT 1MM SP 591H FOR TOWER SYSTEM NOT A PART TO ORDER	EDGE PCI EXPRESS 164	

Table 9. Bill of materials⁽¹⁾

Item	Qty	Schematic label	Value	Description	Part Number	Assy Opt
32	1	J13	HDR_2X10	HDR 2X10 SMT 50 MIL SP 251H AU	FTSH-110-01-L-DV-K	Place jumpers on pin 1–3 and on pin 17–19
33	1	SW1	PB switch	SW SMT 4.0 MM FMS 0.1A MAX 16V MAX ROHS COMPLIANT	7914J-1-000E	
34	14	TP1, TP2, TP3, TP4, TP5, TP6, TP7, TP8, TP9, TP10, TP11, TP12, TP13, TP14	TEST POINT WHITE	TEST POINT WHITE 40 MIL DRILL 180 MIL TH 109L	5002	(2)

Notes

1. NXP does not assume liability, endorse, or warrant components from external manufacturers are referenced in circuit drawings or tables. While NXP offers component recommendations in this configuration, it is the customer's responsibility to validate their application.
2. Do not populate

9 References

Following are URLs where you can obtain information on related NXP products and application solutions:

NXP.com Support Pages	Description	URL
TWR-SB0800-36EVB	Tool Summary Page	www.nxp.com/TWR-SB0800-36EVB
MC34SB0800	Product Summary Page	www.nxp.com/MC34SB0800
Tower System	Tower System Modular Development Board Platform	www.nxp.com/tower
TWR-KL25Z48M	Tool Summary Page	www.nxp.com/TWR-KL25Z48M
K20D72M	Tool Summary Page	www.nxp.com/K20D72M
KV13F120M	Tool Summary Page	www.nxp.com/KV31F120M
Kinetis Design Studio	Software	www.nxp.com/kinetis
CodeWarrior	Software	www.nxp.com/codewarrior

9.1 Support

Visit www.nxp.com/support for a list of phone numbers within your region.

9.2 Warranty

Visit www.nxp.com/warranty for a list of phone numbers within your region.

10 Revision history

Revision	Date	Description of Changes
1.0	1/2016	<ul style="list-style-type: none">• Initial release
	7/2016	<ul style="list-style-type: none">• Updated to NXP document form and style

How to Reach Us:**Home Page:**[NXP.com](http://www.nxp.com)**Web Support:**<http://www.nxp.com/support>

Information in this document is provided solely to enable system and software implementers to use NXP products. There are no expressed or implied copyright licenses granted hereunder to design or fabricate any integrated circuits based on the information in this document. NXP reserves the right to make changes without further notice to any products herein.

NXP makes no warranty, representation, or guarantee regarding the suitability of its products for any particular purpose, nor does NXP assume any liability arising out of the application or use of any product or circuit, and specifically disclaims any and all liability, including without limitation, consequential or incidental damages. "Typical" parameters that may be provided in NXP data sheets and/or specifications can and do vary in different applications, and actual performance may vary over time. All operating parameters, including "typicals," must be validated for each customer application by the customer's technical experts. NXP does not convey any license under its patent rights nor the rights of others. NXP sells products pursuant to standard terms and conditions of sale, which can be found at the following address:

<http://www.nxp.com/terms-of-use.html>.

NXP, the NXP logo, Freescale, the Freescale logo, and SMARTMOS are trademarks of NXP B.V. All other product or service names are the property of their respective owners. All rights reserved.

© 2016 NXP B.V.

Document Number: KTTWRSB0800-36EVBUG

Rev. 1.0

7/2016

