

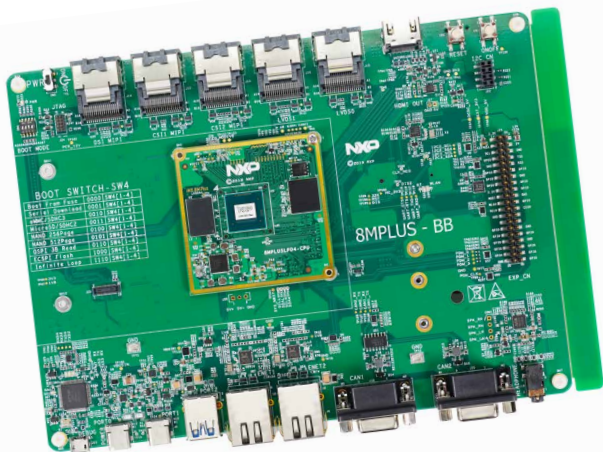

QUICK START GUIDE

i.MX 8M Plus EVK

i.MX 8M PLUS EVK



ABOUT THE i.MX 8M PLUS EVK

The i.MX 8M Plus applications processor is the latest member of the i.MX 8M family. It excels in machine learning, vision, advanced multimedia and industrial IoT applications. Elevating edge intelligence, i.MX 8M Plus processors are the solid foundation for smart homes to smart cities, Industry 4.0 and beyond.

Features

Compute Module:

- i.MX 8M Plus applications processor with up to five cores:
 - 4x Arm® Cortex®-A53
 - 1x Arm Cortex-M7
- LPDDR4 32-bit, 6 GB
- eMMC 5.1, 32 GB
- QSPI NOR flash, 32 MB
- Power management IC (NXP PCA9450C)

Base Board:

- MicroSD card connector
- Two Type-C connectors:
 - Port0 is the only power supply port;
 - Port1 is a USB3.0 connector
- One USB3.0 Type-A connector

- Two 1 Gbit/s Ethernet
 - Port0 supports 1 Gbit/s Ethernet
 - Port1 supports 1 Gbit/s Ethernet with TSN
- AW-CM276MA (NXP 88W8997): Wi-Fi® 5 (802.11ac) 2 x 2 dual-band (2.4/5 GHz) and Bluetooth® 5.1
- Mini-SAS MIPI-DSI connector for display
- Two Mini-SAS LVDS connectors for display
- HDMI Type-A connector for display
- Two Mini-SAS MIPI-CSI connectors for camera
- Two female DB9 connectors for CAN
- USB-to-serial converter for debug
- 3.5 mm headset for audio

GET TO KNOW THE i.MX 8M PLUS EVK

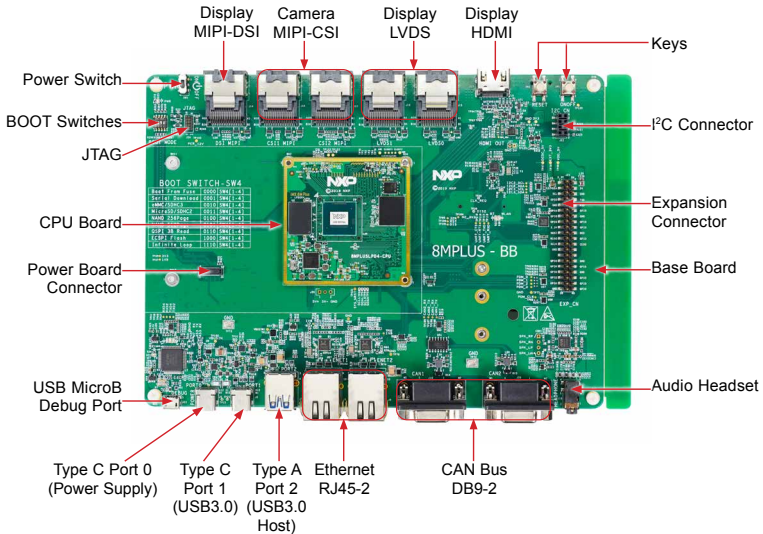

Figure 1: Top view i.MX 8M Plus EVK

GET TO KNOW THE i.MX 8M PLUS EVK CONTINUED

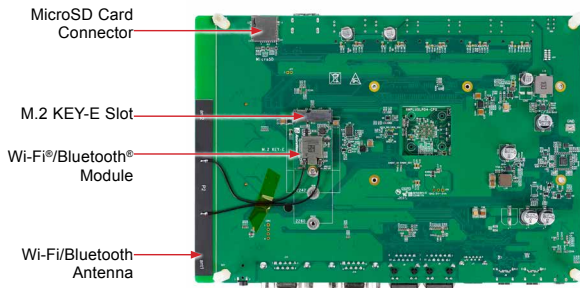

Figure 2: Back view i.MX 8M Plus EVK



Figure 3. i.MX 8M Plus EVK with Heatsink

GETTING STARTED

Unpack the Kit

The i.MX 8M Plus EVK (8MPLUSLPD4-EVK) is shipped with the items listed in Table 1. Ensure the items are available in the EVK box.

Table 1 Kit Contents

ITEM	DESCRIPTION
EVK Board	i.MX 8M Plus EVK
Power Supply	USB Type C 45 W power delivery supply, 5V/3A; 9V/3A; 15V/3A; 20V/2.25A supported
USB Type-C Cable	Cable – Assembly, USB 3.0, Type-C Male to Type-A Male
USB micro-B Cable	Cable – Assembly, USB 2.0, Type-A Male to Micro-B Male
USB Type-C to A Adapter	Adapter – USB 3.0, Type-C male to Type-A female
Software	Linux® BSP image programmed in eMMC
Documentation	Quick Start Guide

Prepare Accessories

The following items in Table 2 are recommended to run with the i.MX 8M Plus EVK.

Table 2 Customer Supplied Accessories

ITEM	DESCRIPTION
IMX-MIPI-HDMI Accessory Card	MIPI-DSI to HDMI adapter board
IMX-LVDS-HDMI Accessory Card	LVDS to HDMI adapter board
MX8-DSI-OLED1/MX8-DSI-OLED1A	MIPI - DSI 1080p OLED display
Mini-SAS cable	8" Mini-SAS cable
HDMI Display	HDMI display that supports a minimum resolution of 1080p60.
HDMI Cable	HDMI cable to connect the HDMI board to HDMI display
Mouse	USB mouse
USB Hub	2 or 4 port USB hub
IMX-OS08A20/MIPI-CSI	4K camera module

GETTING STARTED CONTINUED

Download Software and Tools

Installation software and documentation are available at www.nxp.com/imx8mplusevk. The following are available on the website:

Table 3 Software and Tools

ITEM	DESCRIPTION
Documentation	<ul style="list-style-type: none">• Schematics, layout and Gerber files• i.MX 8M Plus EVK Board Hardware User's Guide• Quick Start Guide• Hardware Design Guide• Power Consumption Measurement
Software Development	Linux® BSPs, Android™ BSPs
Demo Images	Copy of the latest Linux and Android BSP images that are available to program on to the eMMC or SD Card i.MX 8M Plus software can be found www.nxp.com/IMXLINUX and www.nxp.com/IMXANDROID

SETTING UP THE SYSTEM

The following will describe how to run the pre-loaded Linux image on the i.MX 8M Plus EVK.

1 Confirm Boot Switches

The boot switches should be set to boot from the eMMC. SW4[1-4] are used for boot. See table.

BOOT DEVICE	SW4 [1-4]
eMMC/uSDHC3	0010

1 = ON 0 = OFF

2 Connect USB Debug Cable

Connect the micro-B end of a USB cable into debug port J23. Connect the other end of the cable to a PC acting as a host terminal. Four UART connections will appear on the PC, the third port for the Cortex-A53 core and the fourth for Cortex-M7 core system debugging.

The console print will output on “Enhanced COM port,” which can be found in “Device Manager” of the PC.

If the serial port is not recognized, download and install updated drivers as listed in the section “Debug Serial Console” below.

Open the terminal window (i.e., Hyper Terminal or Tera Term), choose the third COM port number and apply the following configuration.

- Baud rate: 115200
- Data bits: 8
- Parity: None
- Stop bits: 1

3 Connect HDMI Display

Connect an HDMI cable to the HDMI connector Jack J17. Connect the other end of the cable to a HDMI display panel.

SETTING UP THE SYSTEM CONTINUED

4 Connect Mouse

Connect the mouse to the USB host connector J7.

5 Connect Power Supply

Connect the USB Type-C plug of the Power Supply to J5 (USB Type-C Port0), then power up the board using switch SW3.

Use only J5 for power delivery to the board.

6 Board Boot Up

As the board boots up, you will see 4 penguins appear in the upper left-hand corner of the monitor, and then you will see the Linux terminal icon on the top left and the timer on right top corner. Congratulations, you are up and running.

ADDITIONAL INFORMATION

Boot Switches

SW4[1-4] is the boot configuration switch, the default boot device is eMMC/uSDHC3, as shown in Table 4. If you want to try other boot devices, you need to change the boot switches to corresponding values as listed in Table 4.

Table 4 Boot Device Settings

BOOT DEVICE	SW4-1	SW4-2	SW4-3	SW4-4
Boot From Fuses	0	0	0	0
USB Serial Download Mode	0	0	0	1
USDHC3 (eMMC boot only, SD3 8-bit) Default	0	0	1	0
USDHC2 (SD boot only, SD2)	0	0	1	1
NAND 8-bit single device 256 page	0	1	0	0
NAND 8-bit single device 512 page	0	1	0	0
QSPI 3B Read	0	1	1	0
QSPI Hyperflash 3.3V	0	1	1	1
ecSPI Boot	1	0	0	0

Note: 1 = ON 0 = OFF X = Don't Care

Debug Serial Console

Windows® users may need to update the serial drivers on your computer. The drivers can be found at <https://www.ftdichip.com/Drivers/VCP.htm>

ADDITIONAL INFORMATION CONTINUED

Do More with Accessory Boards

MX8-DSI-OLED1/MX8-DSI-OLED1A: MIPI-DSI 1080P OLED DISPLAY

Use this OLED display for display and touchscreen support.



MINISASTOCSI: MIPI-CSI CAMERA MODULE

Use this MIPI-CSI camera module for machine vision, video streaming and recording.



IMX-MIPI-HDMI

MIPI-DSI to HDMI adapter card (Mini SAS) to connect MIPI DSI output to HDMI (Color may vary)



IMX-LVDS-HDMI

LVDS-to-HDMI converter adapter card (Mini SAS) to connect LVDS output to HDMI (Color may vary)



ADDITIONAL INFORMATION CONTINUED

IMX-OS08A20: 4K MIPI-CSI CMOS CAMERA MODULE

Use this camera module for up to 4Kp30 machine vision support on the EVK. More information can be found on the OS08A20 [camera module page](#).

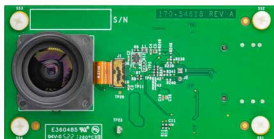

- Output formats:
 - 10-bit RAW RGB
 - 12-bit RAW RGB
- Lens size:
 - 1/2"
- Active array size:
 - 3840 x 2160
- Pixel size:
 - 2.0um x 2.0um

SUPPORT

Visit www.nxp.com/support for a list of phone numbers within your region.

WARRANTY

Visit www.nxp.com/warranty for complete warranty information.

This device complies with Part 15 of the FCC Rules. Operation is subject to the following two conditions:

- (1) This device may not cause harmful interference, and
- (2) This device must accept any interference received, including interference that may cause undesired operation.

Attention that changes or modification not expressly approved by the party responsible for compliance could void the user's authority to operate the equipment.

Note: This product has been tested and found to comply with the limits for a Class B digital device, pursuant to Part 15 of the FCC Rules. These limits are designed to provide reasonable protection against harmful interference in a residential installation. This product generates, uses, and can radiate radio frequency energy and, if not installed and used in accordance with the instructions, may cause harmful interference to radio communications. However, there is no guarantee that interference will not occur in a particular installation. If this product does cause harmful interference to radio or television reception, which can be determined by turning the equipment off and on, the user is encouraged to try to correct the interference by one or more of the following measures:

- Reorient or relocate the receiving antenna.
 - Increase the separation between the equipment and receiver.
 - Connect the equipment into an outlet on a circuit different from that to which the receiver is connected.
 - Consult the dealer or an experienced radio/TV technician for help.
- This equipment should be installed and operated with a minimum distance 20cm between the radiator and your body.

The following information is provided per Article 10.8 of the Radio Equipment Directive 2014/53/EU:

- (a) Frequency bands in which the equipment operates.
- (b) The maximum RF power transmitted.

PN	RF TECHNOLOGY	(A) FREQ RANGES (EU)	(B) MAX TRANSMITTED POWER
8MPLUSLPD4-EVK	WLAN 2.4 GHz Mode 802.11b/g/n	2412 MHz – 2472 MHz	18.5 dBm
	WLAN 5 GHz Mode 802.11a/n/ac	5180 MHz – 5825 MHz	15 dBm
	BLE	2402 MHz – 2480 MHz	4 dBm
	Bluetooth BR/EDR	2402 MHz – 2480 MHz	4 dBm

EUROPEAN DECLARATION OF CONFORMITY (Simplified DoC per Article 10.9 of the Radio Equipment Directive 2014/53/EU)

This apparatus, namely 8MPLUSLPD4-EVK, conforms to the Radio Equipment Directive 2014/53/EU.

The full EU Declaration of Conformity for this apparatus can be found at this location: www.nxp.com/i.MX8MPLUS

www.nxp.com/iMX8MPLUSEVK

NXP and the NXP logo are trademarks of NXP B.V. All other product or service names are the property of their respective owners. The Bluetooth® word mark and logos are registered trademarks owned by Bluetooth SIG, Inc. and any use of such marks by NXP Semiconductors is under license. Windows is a registered trademark of the Microsoft Corporation. Arm and Cortex are trademarks or registered trademarks of Arm Limited (or its subsidiaries) in the US and/or elsewhere. The related technology may be protected by any or all of patents, copyrights, designs and trade secrets. All rights reserved. © 2022 NXP B.V.