

# Electromagnetic Actuator Control

### Overview

Industry demand for precise electronic control of actuators underscores the need for sophisticated controllers that can deliver high performance at a reasonable price. To meet today's application demands for precise actuator control from both position and dynamic points of view, an actuator

system requires a cost-effective controller with the flexibility and speed to process complex control algorithms.

Freescale offers general H-Bridge SMARTMOS™ devices including MC33886, MC33887, and MC33922.

### Key Benefits

- > Uses complex algorithms to provide precise actuator control and flexibility
- > Allows actuator control in one or both directions
- > Allows “soft” and “hard” switching techniques
- > Contains a hardware fault protection block
- > Built-in boot loader and boot Flash
- > Out-of-the-box software components designed to expedite time-to-market and reduce development costs.

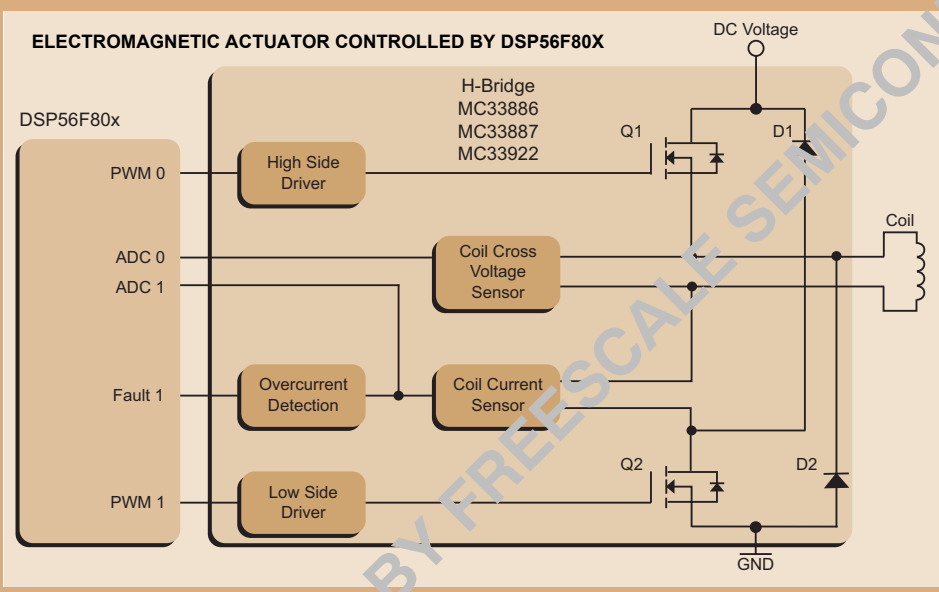

## Freescale Ordering Information<sup>Note</sup>

Part Number	Product Highlights	Additional Information
DSP56F800 Family	80 MHz, 40 MIPS, up to 31.5 KB Flash, 6 K words RAM and Off-Chip Memory, SCI, SPI, ADC, PWM, Quadrature Decoder, Quad Timer, CAN, GPIO, MCU-Friendly Instruction Set, JTAG/OnCE for Debug	<a href="http://www.freescale.com">www.freescale.com</a>
MC33886	H-Bridge Driver (5.2 A)	<a href="http://www.freescale.com/analog">www.freescale.com/analog</a>
MC33887	H-Bridge Driver with Sleep Mode (5.2 A)	
MC33922	Dual Power H-Bridge (4.0 A)	
MC56F801x Family	Up to 32 MHz, 32 MIPS, and up to 16 KB Flash, 4 KB Unified Data/Program RAM, EEPROM Emulation Capability, SCI with LIN, SPI, I <sup>2</sup> C, ADC PWM, GPIO, COP/Watchdog, MCU-Style Software Stack Support, JTAG/OnCE for Debug	<a href="http://www.freescale.com">www.freescale.com</a>
MC56F8100 Family	40 MHz, 40 MIPS, up to 544 KB Flash, 32 KB RAM and Off-Chip Memory, SCI, SPI, ADC, PWM, Quadrature Decoder, Quad Timer, FlexCAN™, GPIO, COP/Watchdog, PLL, MCU-Style Software Stack Support, JTAG/OnCE for Debug	
MC56F8300 Family	60 MHz, 60 MIPS, up to 576 KB Flash, 36 KB RAM and Off-Chip Memory, SCI, SPI, ADC, PWM, Quadrature Decoder, Quad Timer, FlexCAN™, GPIO, COP/Watchdog, PLL, MCU-Style Software Stack Support, JTAG/OnCE for Debug, Temperature Sensor	

Note: Search on the listed part number.

### Design Challenges

Actuator electromagnets are typically controlled in ON/OFF mode with a simple electronic controller. However, increasing demand for more precise control—such as the control of a combustion engine's electric valve—calls for the sophistication of a digital controller. A digital controller increases actuator system flexibility by executing complex algorithms from both the position and dynamic points of view.

Plus, the very fast response of electromagnetic systems drives the need for actuator systems to use a high-performance controller in conjunction with dedicated peripherals.

### Freescale Semiconductor Solution

The Freescale Semiconductor Digital Signal Controllers offer the right combination of performance and peripherals for an actuator system and can control up to six independent electromagnetic actuators.

### Functional Description

These applications require control of the electromagnet coil's current. The electromagnetic force of the actuator is a function of the current going through the electromagnet coil. The modulation of the current according to a predefined profile permits control of the instantaneous electromagnetic force generated by the electromagnet and thus of the movement and position of its core. Typically, the current is modulated

by a pulse width modulation (PWM) technique generated by the controller. The actual current, or force profile depends on the electromagnet construction and application requirements.

The figure on page 1 illustrates an electromagnetic actuator containing the controller, a power stage with feedback sensors, and electromagnet coil that is controlled by one member of the Freescale Semiconductor Digital Signal Controllers. In this application, just one coil is controlled, enabling control of actuator movement in one direction. A second coil using the same hardware structure would permit the controller to control movement of the actuator in both directions. All members of the Digital Signal Controllers contain the same core and the same basic peripherals (PWM, ADC, Quadrature Timers, etc.), so any of the devices could be used for this type of application.

The power stage contains two power switches, Q1 and Q2, in a half-bridge configuration supplied by DC voltage. Flyback diodes D1 and D2 are connected antiparallel to the power switches and coil. The individual switches are driven by high and low side drivers, both controlled directly by the controller. The voltage and current sensors detect the voltage cross and current through the coil. The controller reads and evaluates the analog signals

and controls the switches accordingly. The practical implementation of the individual blocks depends on the level of DC voltage and required actuator output power.

### Possible Switching Techniques

Two basic switching techniques can be implemented—soft switching and hard switching (see figure below). With soft switching, the upper switch Q1 is controlled by the PWM while the lower switch is turned ON for a complete working interval. With hard switching, both upper and lower switches are controlled simultaneously by the PWM. Soft switching gives coil current with lower ripple—di/dt is lower when the upper switch is turned OFF during PWM and the lower switch stays turned ON. This results in a smoother output profile of electromagnetic force. On the other hand, hard switching is simpler from a control point of view. It enables one PWM signal to drive both power switches.

### SOFT SWITCHING AND HARD SWITCHING TECHNIQUES

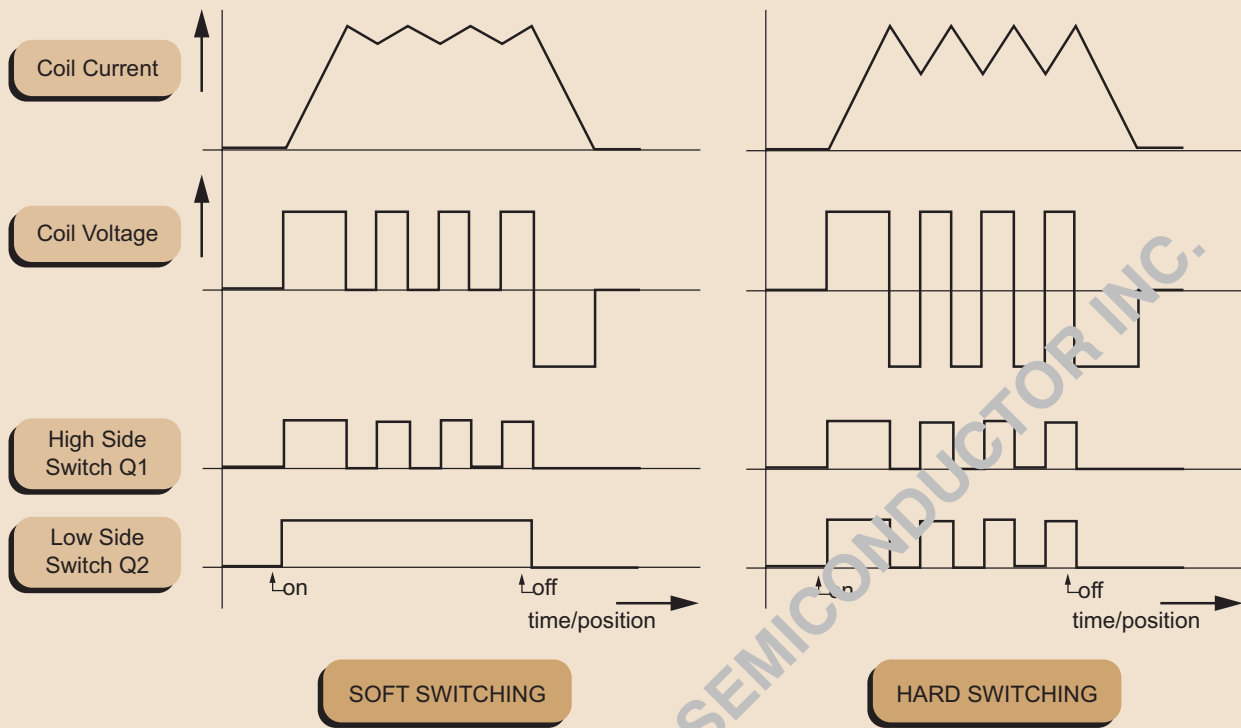

The upper switch Q1 and lower flyback diode D2 of the power stage can be omitted entirely. This configuration leads to soft switching but with a long discharge interval at the end of the working cycle, which results in the generation of undesired electromagnetic force.

During the control cycle, the coil current is sensed and controlled according to the required profile. The choice of the current position profile, stored in the memory of the controller, depends on the actual application requirement. The control algorithm contains the fast current loop executed at the rate of the PWM frequency. A PI or PID controller compares the predefined and actual current and modifies the PWM duty cycle so the actual current follows the correct shape.

#### Digital Signal Controller Operation

The obvious requirement for the controller is the dedicated PWM unit and fast analog-to-digital converter. Each PWM module contains 6 PWM outputs variably configured, with an extremely high degree of freedom for both hard and soft switching techniques. Two PWM outputs per electromagnet coil are used for the control of the power stage switches allowing each PWM to support three actuators. The PWM channels PWM0 and PWM1 are set in independent mode. In the soft switching mode the PWM generator controls the upper switch, while the lower switch is set directly by software. In the hard switching mode, both switches are controlled by the PWM generator.

#### Hardware Fault Protection

The PWM module also contains the hardware fault protection block. By comparing the actual current to threshold, the external comparator generates an overcurrent fault signal. When connected to the fault input of the PWM unit, the overfault signal disables the power stage in case of overcurrent. This increases the protection of the power electronics of the system. The communication interface (SPI or CAN) allows the node to communicate with other parts of the system.

- > Out-of-the-box software components for all on-chip peripherals, in combination with software libraries for motor control, communication, and signal processing, make it easy to develop the most demanding real-time embedded applications.

### Development Tools<sup>Note</sup>

Tool Type	Product Name	Vendor	Description	Additional Information
Software	CW568X	Freescale Semiconductor	CodeWarrior™ Development Studio for 56800/E Controllers with Processor Expert (Metrowerks)	www.freescale.com
Software	Processor Expert	Freescale Semiconductor	Software infrastructure that allows development of efficient, high level software applications that are fully portable and reusable across all 56800/E family of processors.	
Software	CWDSP56800	Freescale Semiconductor	CodeWarrior Software Development Tools for 56800 (Metrowerks)	
Hardware	56F800DEMO	Freescale Semiconductor	56F800 Demonstration Kit	
Hardware	DSP56F801EVM	Freescale Semiconductor	56F801 and 56F802	
Hardware	DSP56F803EVM	Freescale Semiconductor	56F803	
Hardware	DSP56F805EVM	Freescale Semiconductor	56F805	
Hardware	DSP56F807EVM	Freescale Semiconductor	56F807	
Hardware	MC56F8300DSK	Freescale Semiconductor	56F8300 Developers Start Kit	
Hardware	MC56F8323EVM	Freescale Semiconductor	56F8322 and 56F8323	
Hardware	MC56F8367EVM	Freescale Semiconductor	56F834x, 56F835x, 56F836x	
Hardware	DEMO56F8013	Freescale Semiconductor	56F8013	
Hardware	DEMO56F8014	Freescale Semiconductor	56F8014	
Evaluation Kit	KIT33886DHEVB	Metrowerks	H-Bridge Integrated Circuit	www.metrowerks.com
Evaluation Kit	KIT33887DWBEVB	Metrowerks	225 mΩ 150°C and Sleep Mode and Current Sense	
Evaluation Kit	KIT33922PNBEVB	Metrowerks	Dual H-Bridge	

Note: Search on the listed product name.

### Related Documentation<sup>Note</sup>

Document Number	Description	Additional Information
APDPAK	Analog ICs Integrated Solutions Pitch Pack	www.freescale.com
SG1002	Analog Product Selector Guide	
SG1004	Digital Signal Processors Product Selector Guide	
SG1006	Microcontrollers Product Selector Guide	
SG1011	Software and Development Tools Product Selector Guide	

Note: Search on the listed document number.

### Disclaimer

This document may not include all the details necessary to completely develop this design. It is provided as a reference only and is intended to demonstrate the variety of applications for the device.

**Learn More:** Contact the Technical Information Center at +1-800-521-6274 or +1-480-768-2130.

For more information about Freescale products, please visit [www.freescale.com](http://www.freescale.com).