

Building the NiCd/NiMH Battery Charger

Using the MC68HC908QY4A MCU

by: Stanislav Arendarik
Application Engineer, RTAC Roznov

1 Introduction

This application note shows how to build an MCU controlled NiCd/NiMH universal battery charger with the cost-effective MCU MC68HC908QY4A, which is a member of the 8-bit family.

The MC68HC908QY4A features are:

- High performance HC08 CPU core
- 5 V and 3 V operating voltage
- Up to 8 MHz internal bus operation at 5 V
- Trimmable internal oscillator
- Automatic wake-up capability from stop mode
- On-chip in-application programmable flash memory
- On-chip random access memory (RAM)
- Two-channel, 16-bit timer-interface module (TIM)
- Six-channel, 10-bit AtoD converter with internal bandgap reference channel (ADC10)

Contents

1	Introduction	1
1.1	Features	2
2	Brief Description of NiCd and NiMH Batteries	2
2.1	- ΔV Method	3
2.2	ΔT Method	3
2.3	Summary	3
3	Design Strategy	3
4	Charger Description	3
4.1	Hardware Resources	4
4.2	Software Resources	6
5	Schematic	9
6	Final Release	11



- Up to 13 bidirectional GPIO pins with high current sink/source capability, selectable pull-ups on all port pins and shared with KBI, ADC, TIM, and IRQ
- Six-bit keyboard interrupt with wake-up feature (KBI)
- Low-voltage-inhibit module (LVI) with software-selectable trip point
- External synchronous interrupt pin with internal pull-up (IRQ)
- Master asynchronous reset pin with internal pull-up (RST)
- Power saving stop and wait modes

For more information about this MCU, see the data sheet on <http://www.freescale.com>.

You can use the MC68HC908QB8 MCU without altering it. This MCU has incorporated the same features as the MC68HC908QY4A MCU with several internal modules such as the serial-communication-interface (SCI) module and serial-peripheral-interface (SPI) module. These modules are shared with free GPIO pins. The QY4A MCU is the subset of the QB8 MCU. Both MCUs are pin-to-pin compatible.

The final product is intended for automatic, independent, highly efficient, and reliable charging up to four battery cells. It is possible to use the pre-discharging option, mainly for NiCd chemistry. The battery cells can have different capacities or be in a charged state. Each cell is independently tested first to know if it is possible to discharge or charge. Cells that fail are refused and are not discharged or charged.

1.1 Features

- Usable for NiCd and NiMH batteries
- Intelligent charging algorithm controlled by MCU
- High-resolution voltage can sense circuit for reliable charging
- Optional pre-discharging
- Fast and trickle charge modes
- Automatic switch from fast to trickle mode
- Option to select between lower (for AAA cells) or higher (for AA cells) charging current

2 Brief Description of NiCd and NiMH Batteries

NiCd and NiMH chemistry-based batteries have very similar characteristics from the point of view of charging and discharging properties. The typical midpoint voltage is equal to 1.2 V. Typical discharge voltage is 0.9 V (75 percent of 1.2 V). These batteries are typically charged with a constant current and allow the battery to rise to the charged level.

Detecting when the battery is charged is accomplished by various methods. The main method is to detect the $-\Delta V$ voltage drop after the battery is fully charged. Another method of the end-of-charge detection is temperature per time growth. Both methods are associated with the same internal effect of growing internal pressure. The result is that we can reliably monitor the $-\Delta V$ to detect end-of-charge state.

2.1 $-\Delta V$ Method

The battery voltage is monitored after the battery is charged with the constant current. The size of $-\Delta V$ depends on the charging current. This is important to know when the NiMH battery is charged. This method can be used if the charging current is higher than 0.2 C (20 percent of capacity). The $-\Delta V$ drop sharpens after the NiCd chemistry charges or higher charging current used. As the battery approaches full charge, the battery voltage rises faster, reaches the peak, and then begins dropping. After the battery voltage drops a fixed number of mV, the battery is fully charged and the charge cycle terminates.

2.2 ΔT Method

This method is similar to the $-\Delta V$ method. On both types the temperature intensely rises after the battery reaches full charge. This method is usually used as a redundancy when fast-charge is used.

Another internal effect of charging is the rising of the internal pressure. This is caused by the small amount of gas generated inside the cell during charging. This gas is recombined by the cell internally. After the battery enters overcharging, the amount of generated gas is too high and cannot be recombined. Therefore, the internal pressure increases dramatically. Terminate the charging process to avoid physically damaging the charged cells.

2.3 Summary

During charging, battery voltage increases, the cell temperature stays constant or rises slightly (depending on the charging current), and the internal pressure stays constant or increases slightly. After charging (as the cell reaches overcharge), the battery voltage peaks and then gradually declines. The cell temperature and the internal pressure increase dramatically.

3 Design Strategy

The battery charger is based on the $-\Delta V$ detection. To maintain higher safety of the charging process, two additional protection techniques are applied: the battery voltage cannot be higher than the maximum defined voltage per cell (in this case 1.600 V) and the maximum charging time cannot exceed five hours. Each fuse ends the charging process.

The charger is powered by standard 5 V power supply with current capability of 2.4 A. You can select the low (about 300mA) or high (about 650 mA) charging current. The low charging current is intended for the AAA size of accumulators and the higher level for AA size. Simultaneously, you can only change one type of cell, AA or AAA, among the four charger modes. First, discharge and then charge the cells or charge only the cells. Select the correct charging mode by pushing the push button. The battery charger indicates the state of each battery cell — whether the discharge or charge process is in progress. Detailed descriptions of all the functions are in the following sections.

4 Charger Description

The battery charger is controlled by microcontroller MC68HC908QY4A and powered from a standard stabilized 5 V power source or a wall DC adapter. The sufficient current source capability is 2.5A. This

charger can independently discharge or charge up to four battery cells simultaneously. The option for discharge was chosen for NiCd chemistry to avoid the memory effect. It can also be used for NiMH chemistry for new cells that are charged first. The best way is to charge the cells, then discharge and repeatedly charge them to maintain the highest usable capacity. The discharge option is also usable to test the capacity of all inserted cells.

4.1 Hardware Resources

The MCU has the following hardware resources:

- Four output pins control discharging and show each cell's discharge state by the yellow LEDs
- Four output pins control the charging and show each cell's charging state by the green LEDs
- Four input A to D converter pins measure the actual voltage of each battery cell
- One output pin indicates the charger state by the red LED
- One input pin scans the user button

4.1.1 Power Part

Figure 1 shows the simplified diagram of the power part of the charger for discharging and charging.

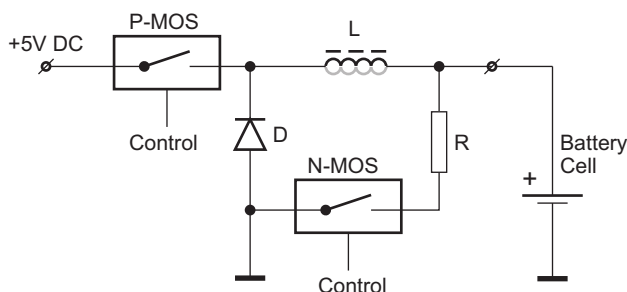

Figure 1. Power Part Of Charger

The discharge circuit for each cell consists of a resistor (R) and the controlled N-MOSFET switch. The N-MOSFET has current source capability of 4A because of lower internal resistance and lower power dissipation. The device temperature stays below 50°C while functioning. The power resistor value maintains the discharge current of approximately 0.65A. In most applications, this is considered the standard working current for both cell types (AA and AAA). Thus, the resistor value is 1.8 Ω. The power dissipation is 0.8 W, but for reliability reasons and lower working temperatures, the 2W type is selected. The working temperature is about 80°C during discharge.

The charge circuit is based on the controlled buck converter. This configuration maintains the highest efficiency of the charger. This circuit consists of the controlled P-MOSFET, power inductor L, and freewheeling diode D. This diode is integrated in the same case with the N-MOSFET device. Toroid is the best type of power inductor. The SMD inductors usually make noise because of mechanical stress on the two parts of ferrite core during current impulse. The toroid core stays silent because of one piece of ferrite. The winding needs to be fixed on the core. The power P-MOSFET device has similar capability of the current source as the N-MOSFET. This device temperature stays below 50°C during charging. The LEDs

for charger-state indication are connected to gates of the MOSFET devices with their working resistors. This option is sufficient for proper indication of all states of charger.

The MCU closely monitors the battery state. The cells temperature never exceeds 45°C during discharging. This is the maximum temperature during charging too, as recommended by NiHM chemistry manufacturers. The values are the result of testing the various NiCd and NiMH cells and capacities (from 500mAh to 2500mAh).

4.1.2 Measurement Part

The circuit for measuring the battery voltage is made of the reference voltage source (zener diode) of 1 V and operational amplifier with gain equal to 5. This circuit converts the full 10-bit ADC's input range of 0 to 5 V to range of +0.8 V to +1.8 V of the actual battery voltage. It improves the final ADC resolution to 1mV too and enables it to choose the $-\Delta V$ method to detect the end of each cell's charge point. Figure 2 shows the simplified diagram of the circuit.

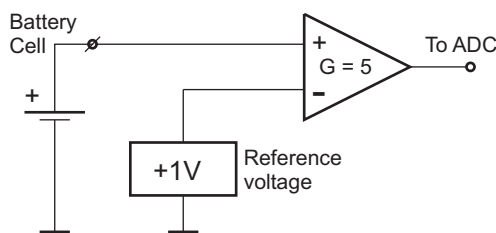

Figure 2. ADC Input Amplifier

For the charger to function properly, you must use the OpAmp that has a true rail-to-rail. The output voltage of the OpAmp should be capable of a swing as close as possible ($<40\text{mV}$) to both power supply rails—GND and V_{dd} . The reference voltage is based on the 1.00 V zener diode and is common for all four amplifier channels. This option maintains the sufficient stability and accuracy of the reference voltage. This is also the most cost-efficient solution.

4.1.3 Control Part

The control unit is the heart of the charger. Figure 3 shows the simplified diagram.

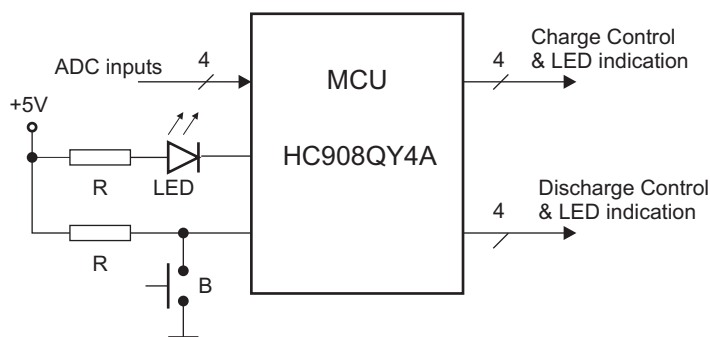

Figure 3. Control Unit with Input and Output Signals

The control unit is based on HC908QY4A MCU. The MCU provides the 8-bit PortB to control the charge and discharge. The 4-pins from PortA as ADC inputs measure each cell's voltage independently. One pin of PortA as output uses a red LED light to indicate the charger state and one pin of PortA acts as an input for the user button.

Figure 4 shows the two main functions of the red LED light and user button.

4.1.3.1 Start of Charging Procedure

After the charger starts running, select one of the main functions. The options are:

- Charge only the cells of higher capacity. The charging current is about 550 to 650mA
- First discharge and then automatically charge the cells of the higher capacity
- Charge only the cells of lower capacity. The charging current is about 250 to 300mA
- First discharge and then automatically charge the cells of the lower capacity

In this state, the LED remains lit and the charger waits for your action. After you press the button, the LED switches off and the first user time slot opens. Approximately two seconds later, the LED switches repeatedly and the second user time slot opens. This process is the same for the third time slot. The fourth time slot starts after the LED lights. Then, the MCU waits for the button to be released. This finishes your selection of the main charger's function.

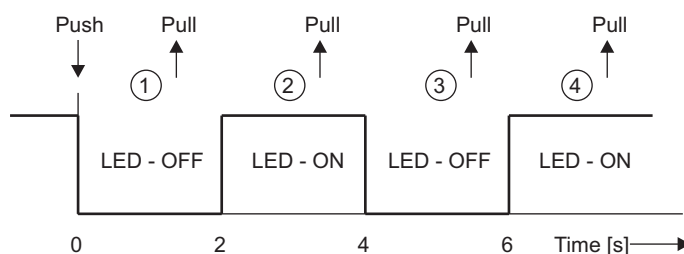

Figure 4. Function Time Slots Definition

For example, if you press the button and release it in time slot two, the discharge and charge of the high capacity cells function is selected. If you release the button in time slot one, only the charge function of the high capacity cells is selected.

4.1.3.2 END of Charge Behavior

After the charger finishes charging, the red LED blinks. You can now see if some cells failed or were refused from charging. If you press the button while the red LED blinks, the yellow LED marks the failed cell. The failed battery cell, which is internally shorted or has high internal resistance, is not usable and are not charged.

4.2 Software Resources

Main software resources for each cell independently:

- Controlled discharge
- Controlled charge

- Selection between high (AA type) or low (AAA type) capacity
- Highly depleted cell recognition
- Voltage cell detection during discharging
- Voltage cell sensing and $-\Delta V$ detection while charging in progress
- Zero ΔV detection during charging
- High voltage cell detection during charging
- Trickle charge after charging or charged cells are inserted
- Failed cell recognition
- Detection if cell is removed during charging
- After charging, the charger shows the failed cells
- Charging overtime protection — Maximum charging time is 5.5 hours
- Charger state indication — Discharging, charging, finished
- You can select one of four charging modes

4.2.1 Inserted Cell Recognition

After the charger starts to run, it first tests each cell position to learn whether the cell is inserted. If the cell is not inserted, this position is refused from the discharging or charging process.

The charger tests whether the cells are inserted during the whole charging period. If a discharged or charged cell is removed from the charger, the cell position is marked as failed and switched off. This means neither charging nor discharging is active in that position.

4.2.2 Selection of Cell Capacity

The charger can use the low or high level of charging current in accordance to the inserted battery cells. You must decide which level to use. The low level is mainly for AAA types and the high level for AA types. You can decide in accordance of the actual capacity of the inserted cells. Usually, the low level can be used up to 1000mAh capacity and the high level for higher capacity.

4.2.3 Highly Depleted Cell Recognition

If the cell voltage is lower than the minimum value (0.95 V), the cell can be highly depleted or damaged. If the cell is depleted only, the voltage is usually from 0.5 V to 0.9 V. In this case, the charger provides the small amount of the charging current to recognize if the cell is damaged. If the cell is damaged, the voltage stays low and the cell is denied charging and marked as failed. If the voltage is higher than 0.9 V, the cell is considered chargeable.

If the cell voltage is higher than 1.40 V, the cell is not considered charged. Then, only the trickle charge current is applied. You can also select the discharge option with consecutive charging, too. This option is effective for testing cell capacity.

4.2.4 Controlled Discharge

As the low limit for discharge, the NiCd and NiMH chemistry has 0.9 V to 1.00 V. This charger uses the discharge resistor of 1.8 Ω . Therefore, the discharge current is about 0.5A. This current depends on the cell's charged state. The MCU monitors the cell's actual voltage during discharge. Discharging ends after the voltage reaches 0.95 V. The yellow LEDs light during discharging.

4.2.5 Controlled Charge

The charge state starts automatically after the previous discharge process finishes or after the user charge only request is applied. The charging current is determined by the inductance value and the time duration of the charging impulse applied to P-MOSFET. The time pulse duration is internally set to 650mA (300mA, respectively.) with the inductance value. The charging current is slightly influenced by the actual cell's voltage too, but this influence is not important. The green LEDs are lit during fast charging.

In the trickle charge state, the charge impulse is short to maintain the correct trickle-current level. The charger meets the manufacturer's suggested trickle charge current (from 2.5mA to 5mA per cell). The red LED blinks during trickle charge.

4.2.6 Cell's Voltage Sensing and $-\Delta V$ Detection

The negative voltage drop determines the end of charge. The amplitude of this negative voltage drop differs between NiCd and NiMH chemistry. This amplitude is larger on NiCd chemistry and is in the range of 10–th millivolts (20 to 50mV). The NiMH chemistry has this voltage drop significantly. It varies from 2 to 5mV or it can be equal to zero. The amplitude also depends on the used charging current (higher current = deeper voltage drop).

This charger checks the voltage drop of -2mV or the zero voltage drop in 20 minutes. After one condition occurs, the cell is considered charged, and charging of the appropriate cell finishes. The actual cell voltage during charging is also checked. If this voltage exceeds 1.600 V, the cell is considered low-quality, or damaged, because of the high internal resistance. This cell is then refused and marked as failed.

4.2.7 Reliability of Charging Process

The charger must reliably charge the cells to 100% capacity. The reliability means that no overcharge or excess of the temperature occurs during charging. The actual cell voltage, temperature, and the internal pressure are closely dependent. After the cell is nearly charged, the actual temperature and internal pressure rise intensely. After the cell reaches the full charge, its voltage remains constant or lowers and terminates the charging current. Measuring the constant cell's voltage duration improves charging reliability. If the voltage stays constant for more than 20 minutes, the charging current terminates. The charger measures the total charging time. This time is limited to five and a half hours and is sufficient for the full charge of the four cells (up to 2700mAh).

5 Schematic

The complete schematic is split into two. [Figure 5](#) shows the power part. [Figure 6](#) shows the measurement part.

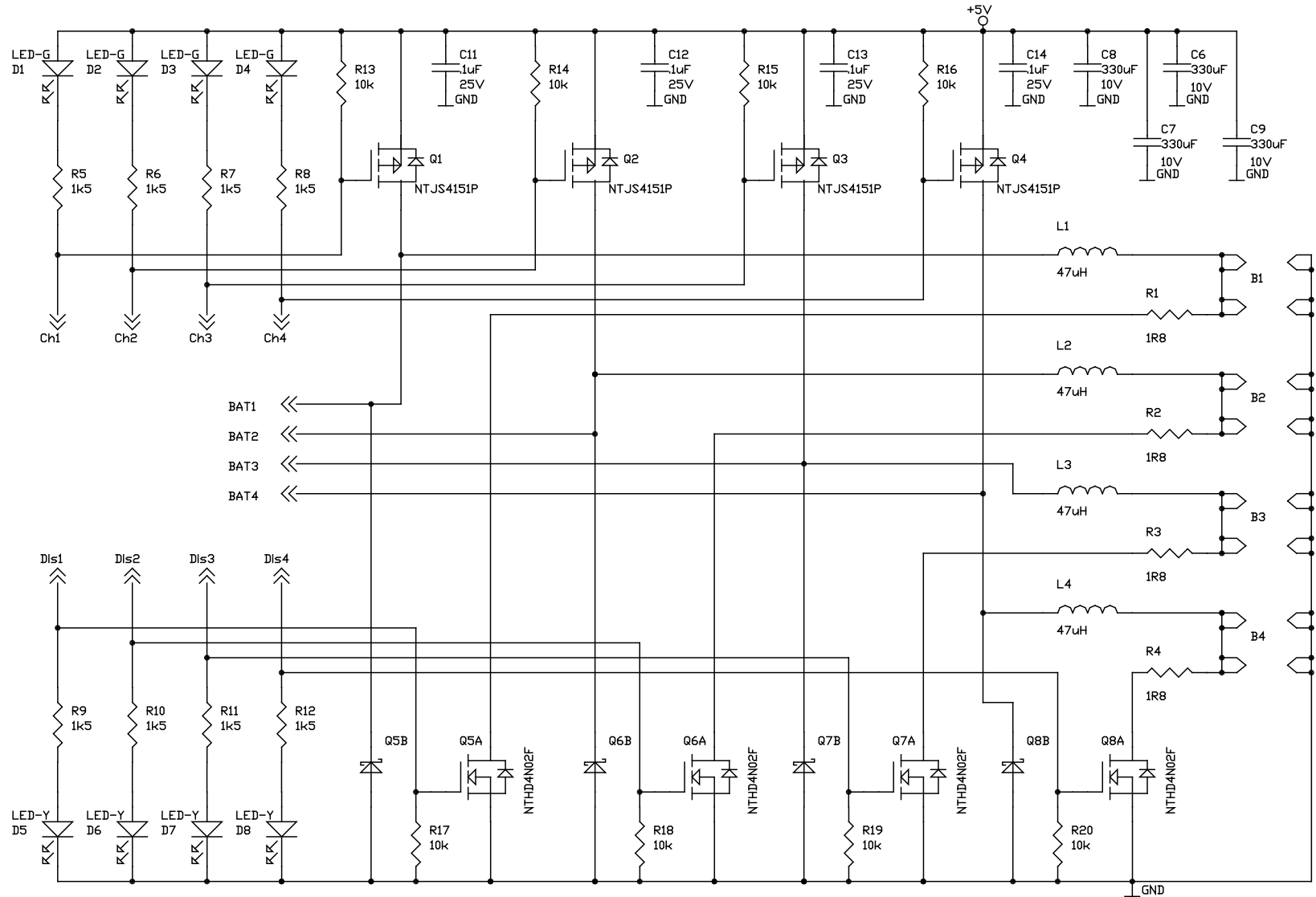

Figure 5. Power Part

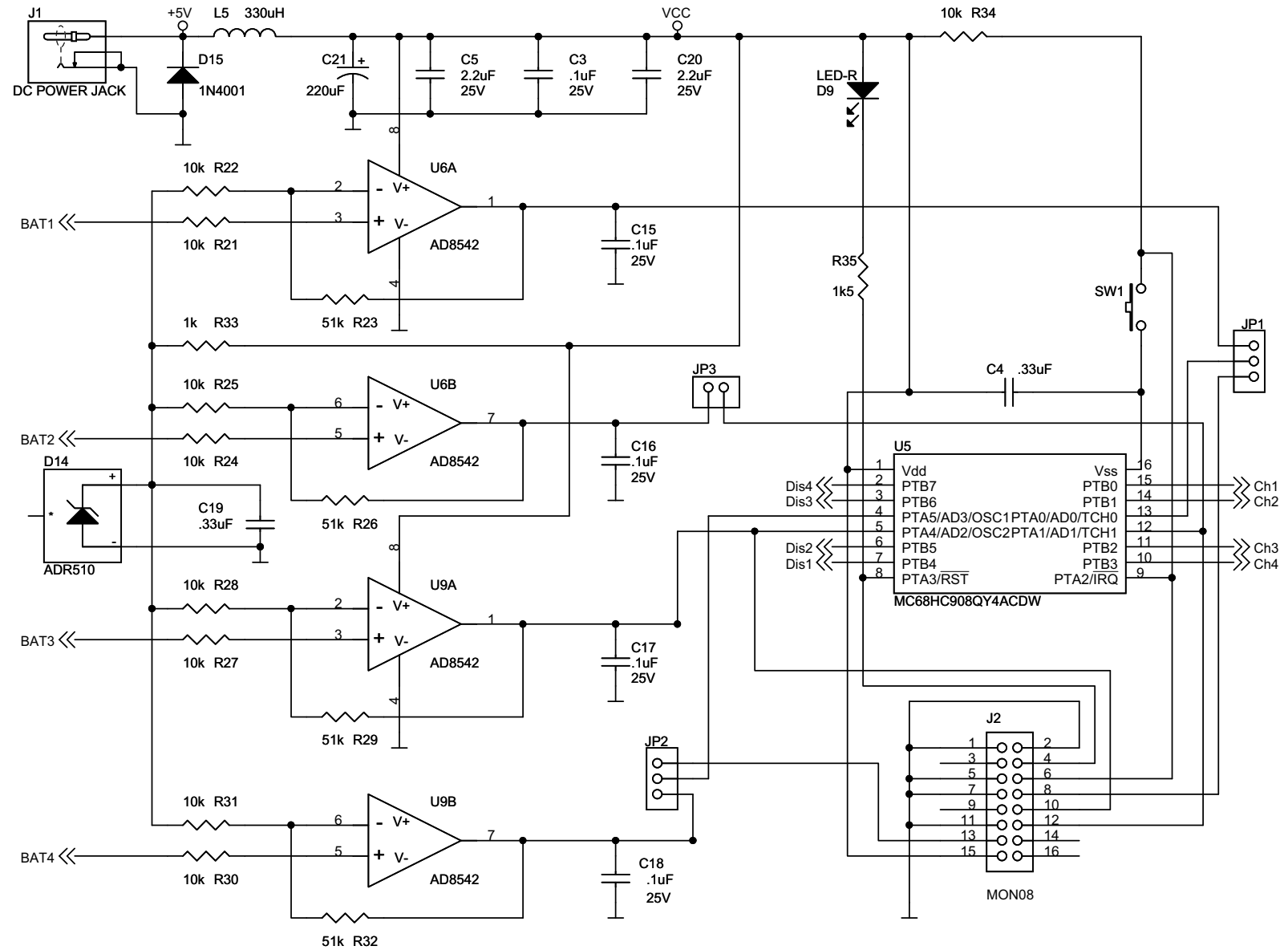

Figure 6. Measurement Part

On the upper side of PCB is the power-supply connector, user button, MCU MC68HC908QY4A, operational amplifiers, all LEDs, MOSFET power switches, power inductors, power resistors for discharge, and battery holders for AA cells. The battery holders for AAA cells and the main high-volume capacitors are on the bottom side.

The operational amplifiers need to be true rail-to-rail at output. The AD8542 is used in this reference design because of good output performance. The +1.00 V reference zener diode is an ADR510. Only one value is available at a time. The power MOSFET switches are P-type of NTJS4151 (4.2A) and N-type of NTHD4N02F (3.9A). This device comprises the schottky diode too. The power inductors are SMD type (12.5 x 12.5 x 7.5mm) for currents higher than 4A. Using the toroid diameter with a 10mm diameter is also possible. This is better for a lower switching frequency because there is no noise production.

The MON08 header assembly was only assembled on the first prototype, but can be populated if desired. On the final version, the MCU was programmed and then assembled. The whole charger board is placed into a plastic case with windows cut for battery cells and holes for LEDs, the button, and a power supply connector.

NOTE

When placing the cells in the right polarity, the positive side is oriented to the center of the board.

6 Final Release

Figure 7 shows the charger's final release. The whole charger can be housed in a plastic case.

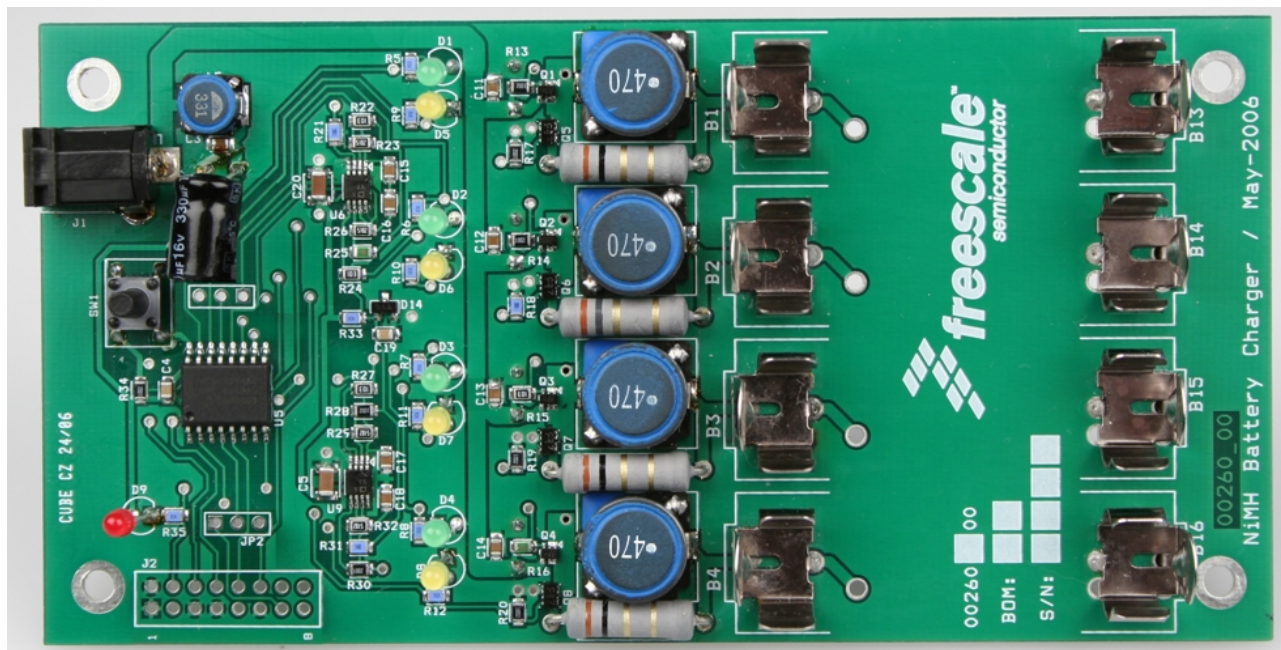

Figure 7. Ready to Use

How to Reach Us:

Home Page:

www.freescale.com

E-mail:

support@freescale.com

USA/Europe or Locations Not Listed:

Freescale Semiconductor
Technical Information Center, CH370
1300 N. Alma School Road
Chandler, Arizona 85224
+1-800-521-6274 or +1-480-768-2130
support@freescale.com

Europe, Middle East, and Africa:

Freescale Halbleiter Deutschland GmbH
Technical Information Center
Schatzbogen 7
81829 Muenchen, Germany
+44 1296 380 456 (English)
+46 8 52200080 (English)
+49 89 92103 559 (German)
+33 1 69 35 48 48 (French)
support@freescale.com

Japan:

Freescale Semiconductor Japan Ltd.
Headquarters
ARCO Tower 15F
1-8-1, Shimo-Meguro, Meguro-ku,
Tokyo 153-0064
Japan
0120 191014 or +81 3 5437 9125
support.japan@freescale.com

Asia/Pacific:

Freescale Semiconductor Hong Kong Ltd.
Technical Information Center
2 Dai King Street
Tai Po Industrial Estate
Tai Po, N.T., Hong Kong
+800 2666 8080
support.asia@freescale.com

For Literature Requests Only:

Freescale Semiconductor Literature Distribution Center
P.O. Box 5405
Denver, Colorado 80217
1-800-441-2447 or 303-675-2140
Fax: 303-675-2150
LDCForFreescaleSemiconductor@hibbertgroup.com

Document Number: AN3392
Rev. 0
04/2006

Information in this document is provided solely to enable system and software implementers to use Freescale Semiconductor products. There are no express or implied copyright licenses granted hereunder to design or fabricate any integrated circuits or integrated circuits based on the information in this document.

Freescale Semiconductor reserves the right to make changes without further notice to any products herein. Freescale Semiconductor makes no warranty, representation or guarantee regarding the suitability of its products for any particular purpose, nor does Freescale Semiconductor assume any liability arising out of the application or use of any product or circuit, and specifically disclaims any and all liability, including without limitation consequential or incidental damages. "Typical" parameters that may be provided in Freescale Semiconductor data sheets and/or specifications can and do vary in different applications and actual performance may vary over time. All operating parameters, including "Typicals", must be validated for each customer application by customer's technical experts. Freescale Semiconductor does not convey any license under its patent rights nor the rights of others. Freescale Semiconductor products are not designed, intended, or authorized for use as components in systems intended for surgical implant into the body, or other applications intended to support or sustain life, or for any other application in which the failure of the Freescale Semiconductor product could create a situation where personal injury or death may occur. Should Buyer purchase or use Freescale Semiconductor products for any such unintended or unauthorized application, Buyer shall indemnify and hold Freescale Semiconductor and its officers, employees, subsidiaries, affiliates, and distributors harmless against all claims, costs, damages, and expenses, and reasonable attorney fees arising out of, directly or indirectly, any claim of personal injury or death associated with such unintended or unauthorized use, even if such claim alleges that Freescale Semiconductor was negligent regarding the design or manufacture of the part.

Freescale™ and the Freescale logo are trademarks of Freescale Semiconductor, Inc. All other product or service names are the property of their respective owners.

© Freescale Semiconductor, Inc. 2007. All rights reserved.

RoHS-compliant and/or Pb-free versions of Freescale products have the functionality and electrical characteristics as their non-RoHS-compliant and/or non-Pb-free counterparts. For further information, see <http://www.freescale.com> or contact your Freescale sales representative.

For information on Freescale's Environmental Products program, go to <http://www.freescale.com/epp>.